

OMAP5910 Dual-Core Processor

Data Manual



Literature Number: SPRS197
August 2002

PRODUCT PREVIEW information concerns products in the formative or design phase of development. Characteristic data and other specifications are design goals. Texas Instruments reserves the right to change or discontinue these products without notice.



Printed on Recycled Paper

IMPORTANT NOTICE

Texas Instruments Incorporated and its subsidiaries (TI) reserve the right to make corrections, modifications, enhancements, improvements, and other changes to its products and services at any time and to discontinue any product or service without notice. Customers should obtain the latest relevant information before placing orders and should verify that such information is current and complete. All products are sold subject to TI's terms and conditions of sale supplied at the time of order acknowledgment.

TI warrants performance of its hardware products to the specifications applicable at the time of sale in accordance with TI's standard warranty. Testing and other quality control techniques are used to the extent TI deems necessary to support this warranty. Except where mandated by government requirements, testing of all parameters of each product is not necessarily performed.

TI assumes no liability for applications assistance or customer product design. Customers are responsible for their products and applications using TI components. To minimize the risks associated with customer products and applications, customers should provide adequate design and operating safeguards.

TI does not warrant or represent that any license, either express or implied, is granted under any TI patent right, copyright, mask work right, or other TI intellectual property right relating to any combination, machine, or process in which TI products or services are used. Information published by TI regarding third-party products or services does not constitute a license from TI to use such products or services or a warranty or endorsement thereof. Use of such information may require a license from a third party under the patents or other intellectual property of the third party, or a license from TI under the patents or other intellectual property of TI.

Reproduction of information in TI data books or data sheets is permissible only if reproduction is without alteration and is accompanied by all associated warranties, conditions, limitations, and notices. Reproduction of this information with alteration is an unfair and deceptive business practice. TI is not responsible or liable for such altered documentation.

Resale of TI products or services with statements different from or beyond the parameters stated by TI for that product or service voids all express and any implied warranties for the associated TI product or service and is an unfair and deceptive business practice. TI is not responsible or liable for any such statements.

Mailing Address:

Texas Instruments
Post Office Box 655303
Dallas, Texas 75265

REVISION HISTORY

REVISION	DATE	PRODUCT STATUS	HIGHLIGHTS
*	August 2002	Product Preview	Original

Contents

<i>Section</i>	<i>Page</i>
1 OMAP5910 Features	1
2 Introduction	2
2.1 Description	2
2.1.1 TMS320C55x DSP Core	2
2.1.2 TI-Enhanced TI925T RISC Processor	3
2.2 Terminal Assignments	4
2.3 Terminal Characteristics and Multiplexing	7
2.4 Signal Description	18
3 Functional Overview	28
3.1 Functional Block Diagram Features	29
3.2 MPU Memory Maps	31
3.2.1 MPU Global Memory Map	31
3.2.2 MPU Subsystem Registers Memory Map	32
3.3 DSP Memory Maps	33
3.3.1 DSP Global Memory Map	33
3.3.2 On-Chip Dual-Access RAM (DARAM)	34
3.3.3 On-Chip Single-Access RAM (SARAM)	34
3.3.4 DSP I/O Space Memory Map	35
3.4 DSP External Memory (Managed by MMU)	36
3.5 MPU and DSP Private Peripherals	38
3.5.1 Timers	38
3.5.2 32k Timer (MPU only)	38
3.5.3 Watchdog Timer	38
3.5.4 Interrupt Handlers	38
3.5.5 LCD Controller	38
3.6 MPU Public Peripherals	39
3.6.1 USB1.1 Host Controller	39
3.6.2 USB1.1 Function Peripheral	40
3.6.3 Multichannel Buffered Serial Port (McBSP)	40
3.6.4 I ² C Master/Slave Interface	41
3.6.5 Microwire Serial Interface	41
3.6.6 Multimedia Card/Secure Digital (MMC/SD) Interface	41
3.6.7 HDQ/1-Wire Interface	42
3.6.8 Camera Interface	42
3.6.9 MPUIO/Keyboard Interface	42
3.6.10 Pulse-Width Light (PWL)	42
3.6.11 Pulse-Width Tone (PWT)	42
3.6.12 LED Pulse Generator	43
3.6.13 Real-Time Clock	43
3.6.14 Frame Adjustment Counter	43
3.7 DSP Public Peripherals	43
3.7.1 Multichannel Buffered Serial Port (McBSP)	43
3.7.2 Multichannel Serial Interface (MCSI)	44

Section	Page
3.8 Shared Peripherals	44
3.8.1 Universal Asynchronous Receiver/Transmitter (UART)	44
3.8.2 General-Purpose I/O (GPIO)	45
3.8.3 Mailbox Registers	45
3.9 System DMA Controller	46
3.10 DSP DMA Controller	47
3.11 Traffic Controller (Memory Interfaces)	47
3.12 Interprocessor Communication	48
3.12.1 MPU/DSP Mailbox Registers	48
3.12.2 MPU Interface (MPUI)	48
3.12.3 MPU/DSP Shared Memory	49
3.13 DSP Hardware Accelerators	49
3.13.1 DCT/IDCT Accelerator	49
3.13.2 Motion Estimation Accelerator	49
3.13.3 Pixel Interpolation Accelerator	49
3.14 Power Supply Connection Examples	50
3.15 MPU Register Descriptions	51
3.15.1 MPU Private Peripheral Registers	52
3.15.2 MPU Public Peripheral Registers	59
3.15.3 MPU Configuration Registers	68
3.16 DSP Register Descriptions	75
3.16.1 DSP Private Peripheral Registers	75
3.16.2 DSP Public Peripheral Registers	81
3.16.3 DSP Configuration Registers	86
3.16.4 MPU/DSP Shared Peripheral Register Descriptions	88
3.17 Interrupts	93
4 Documentation Support	97
4.1 Device and Development-Support Tool Nomenclature	97
5 Electrical Specifications	98
5.1 Absolute Maximum Ratings	98
5.2 Recommended Operating Conditions	99
5.3 Electrical Characteristics Over Recommended Operating Case Temperature Range (Unless Otherwise Noted)	100
5.4 Package Thermal Resistance Characteristics	101
5.5 Timing Parameter Symbology	101
5.6 Clock Specifications	102
5.6.1 32-kHz Oscillator and Input Clock	102
5.6.2 12-MHz Oscillator and Input Clock	103
5.6.3 Internal Clock Speed Limitations	104
5.7 Reset Timings	105
5.7.1 OMAP5910 Device Reset	105
5.7.2 OMAP5910 MPU Core Reset	106
5.8 External Memory Interface Timing	107
5.8.1 EMIFS/Flash Interface Timing	107
5.8.2 EMIFF/SDRAM Interface Timing	114

<i>Section</i>	<i>Page</i>
5.9 Multichannel Buffered Serial Port (McBSP) Timings	118
5.9.1 McBSP Transmit and Receive Timings	118
5.9.2 McBSP as SPI Master or Slave Timing	121
5.10 Multichannel Serial Interface (MCSI)	125
5.11 Camera Interface Timings	127
5.12 LCD Controller Timings	128
5.13 Multimedia Card/Secure Digital (MMC/SD) Timings	130
5.14 I ² C Timings	132
5.15 Universal Serial Bus (USB) Timings	133
5.16 Microwire Interface Timings	134
6 Glossary	135
7 Mechanical Data	139
7.1 Ball Grid Array Mechanical Data	139

List of Figures

<i>Figure</i>		<i>Page</i>
2-1	OMAP5910 GZG MicroStar BGA Package (Bottom View)	4
3-1	OMAP5910 Functional Block Diagram	28
3-2	DSP MMU Off	36
3-3	DSP MMU On	37
3-4	Supply Connections for a Typical System	50
3-5	Supply Connections for a System with 1.8-V SDRAM	51
5-1	3.3-V Test Load Circuit	101
5-2	32-kHz Oscillator External Crystal	102
5-3	32-kHz Input Clock	103
5-4	Internal System Oscillator External Crystal	103
5-5	Device Reset Timings	105
5-6	MPU Core Reset Timings	106
5-7	Asynchronous Memory Read Timing	109
5-8	Asynchronous 32-Bit Read	110
5-9	Asynchronous Read – Page Mode ROM	111
5-10	Asynchronous Memory Write Timing	112
5-11	Synchronous Burst Read	113
5-12	Two SDRAM RD (Read) Commands (Active Row)	115
5-13	Two SDRAM WRT (Write) Commands (Active Row)	115
5-14	SDRAM ACTV (Activate Row) Command	116
5-15	SDRAM DCAB (Precharge/Deactivate Row) Command	116
5-16	SDRAM REFR (Refresh) Command	117
5-17	SDRAM MRS (Mode Register Set) Command	117
5-18	McBSP Receive Timings	120
5-19	McBSP Transmit Timings	120
5-20	McBSP Timing as SPI Master or Slave: CLKSTP = 10b, CLKXP = 0	121
5-21	McBSP Timing as SPI Master or Slave: CLKSTP = 11b, CLKXP = 0	122
5-22	McBSP Timing as SPI Master or Slave: CLKSTP = 10b, CLKXP = 1	123
5-23	McBSP Timing as SPI Master or Slave: CLKSTP = 11b, CLKXP = 1	124
5-24	MCSI Master Mode Timings	126
5-25	MCSI Slave Mode Timings	126
5-26	Camera Interface Timings	127
5-27	TFT Mode (LCD.HS/LCD.VS on Falling and LCD.Px on Rising LCD.PCLK)	128
5-28	TFT Mode (LCD.HS/LCD.VS on Rising and LCD.Px on Falling LCD.PCLK)	129
5-29	MMC/SD Host Command Timings	130
5-30	MMC/SD Card Response Timings	130
5-31	MMC/SD Host Write Timings	131

Figures

<i>Figure</i>		<i>Page</i>
5–32	MMC/SD Host Read and Card CRC Status Timings	131
5–33	I ² C Timings	132
5–34	USB Integrated Transceiver Interface Timings	133
5–35	Microwire Timings	134
7–1	OMAP5910 289-Ball MicroStar BGA Plastic Ball Grid Array (GZG) Package	139

List of Tables

<i>Table</i>		<i>Page</i>
2-1	Terminal Assignments	4
2-2	Terminal Characteristics and Multiplexing	8
2-3	Signal Description	18
3-1	OMAP5910 MPU Global Memory Map	31
3-2	MPU Private Peripheral Registers	32
3-3	MPU Public Peripheral Registers	32
3-4	MPU/DSP Shared Peripheral Registers	32
3-5	DSP Public Peripheral Registers (Accessible via MPUI Port)	33
3-6	MPU Configuration Registers	33
3-7	DSP Global Memory Map	33
3-8	DARAM Blocks	34
3-9	SARAM Blocks	34
3-10	DSP Private Peripheral Registers	35
3-11	DSP Public Peripheral Registers	35
3-12	DSP/MPU Shared Peripheral Registers	35
3-13	DSP Configuration Registers	35
3-14	MPU Timer 1 Registers	52
3-15	MPU Timer 2 Registers	52
3-16	MPU Timer 3 Registers	52
3-17	MPU Watchdog Timer Registers	52
3-18	MPU Level 1 Interrupt Handler Registers	53
3-19	MPU Level 2 Interrupt Handler Registers	54
3-20	System DMA Controller Registers	55
3-21	LCD Controller Registers	58
3-22	McBSP2 Registers	60
3-23	Microwire Registers	60
3-24	I ² C Registers	61
3-25	HDQ/1-Wire Interface Registers	61
3-26	MMC/SD Registers	62
3-27	USB Function Registers	63
3-28	USB Host Controller Registers	65
3-29	Camera Interface Registers	65
3-30	MPU I/O/Keyboard Registers	66
3-31	PWL Registers	66
3-32	PWT Registers	66
3-33	LED Pulse Generator 1 Registers	66
3-34	LED Pulse Generator 2 Registers	66
3-35	32k Timer Registers	66
3-36	Real-Time Clock Registers	67
3-37	Frame Adjustment Counter Registers	67
3-38	OMAP 5910 Pin Configuration Registers	69
3-39	Local Bus Control Registers	69
3-40	Local Bus MMU Registers	70
3-41	DSP MMU Registers	71
3-42	MPUI Registers	71

<i>Table</i>	<i>Page</i>	
3-43	TIPB (Private) Bridge 1 Configuration Registers	71
3-44	TIPB (Public) Bridge 2 Configuration Registers	72
3-45	MPU UART TIPB Bus Switch Registers	72
3-46	Traffic Controller Registers	73
3-47	MPU Clock/Reset/Power Mode Control Registers	73
3-48	DPLL1 Register	73
3-49	Ultra Low-Power Device Module Registers	74
3-50	Device Die Identification Registers	74
3-51	JTAG Identification Code Register	74
3-52	DSP DMA Controller Registers	76
3-53	DSP Timer 1 Registers	79
3-54	DSP Timer 2 Registers	79
3-55	DSP Timer 3 Registers	79
3-56	DSP Watchdog Timer Registers	79
3-57	DSP Interrupt Interface Registers	79
3-58	DSP Level 2 Interrupt Handler Registers	80
3-59	McBSP1 Registers	81
3-60	McBSP3 Registers	82
3-61	MCSI1 Registers	84
3-62	MCSI2 Registers	85
3-63	DSP Instruction Cache Registers	86
3-64	DSP EMIF Configuration Register	86
3-65	DSP TIPB Bridge Configuration Registers	86
3-66	DSP UART TIPB Bus Switch Registers	87
3-67	DSP Clock Mode Registers	87
3-68	UART1 Registers	89
3-69	UART2 Registers	90
3-70	UART3/IrDA Registers	91
3-71	MPU/DSP Shared GPIO Registers	92
3-72	MPU/DSP Shared Mailbox Registers	92
3-73	MPU Level 1 and Level 2 Interrupt Mappings	93
3-74	DSP Level 1 Interrupt Mappings	95
3-75	DSP Level 2 Interrupt Mappings	96
5-1	Thermal Resistance Characteristics	101
5-2	32-kHz Oscillator Switching Characteristics	102
5-3	32-kHz Input Clock Timing Requirements	103
5-4	12-MHz Oscillator Switching Characteristics	104
5-5	Internal Clock Speed Limitations	104
5-6	OMAP5910 Device Reset Timing Requirements	105
5-7	$\overline{\text{MPU_RST}}$ Timing Requirements	106
5-8	$\overline{\text{MPU_RST}}$ Switching Characteristics	106
5-9	EMIFS/Flash Interface Timing Requirements	107
5-10	EMIFS/Flash Interface Switching Characteristics	108
5-11	EMIFF/SDRAM Interface Timing Requirements	114
5-12	EMIFF/SDRAM Interface Switching Characteristics	114
5-13	McBSP Timing Requirements	118

<i>Table</i>	<i>Page</i>
5-14 McBSP Switching Characteristics	119
5-15 McBSP as SPI Master or Slave Timing Requirements (CLKSTP = 10b, CLKXP = 0)	121
5-16 McBSP as SPI Master or Slave Switching Characteristics (CLKSTP = 10b, CLKXP = 0)	121
5-17 McBSP as SPI Master or Slave Timing Requirements (CLKSTP = 11b, CLKXP = 0)	122
5-18 McBSP as SPI Master or Slave Switching Characteristics (CLKSTP = 11b, CLKXP = 0)	122
5-19 McBSP as SPI Master or Slave Timing Requirements (CLKSTP = 10b, CLKXP = 1)	123
5-20 McBSP as SPI Master or Slave Switching Characteristics (CLKSTP = 10b, CLKXP = 1)	123
5-21 McBSP as SPI Master or Slave Timing Requirements (CLKSTP = 11b, CLKXP = 1)	124
5-22 McBSP as SPI Master or Slave Switching Characteristics (CLKSTP = 11b, CLKXP = 1)	124
5-23 MCSI Timing Requirements	125
5-24 MCSI Switching Characteristics	125
5-25 Camera Interface Timing Requirements	127
5-26 LCD Controller Switching Characteristics	128
5-27 MMC/SD Timing Requirements	130
5-28 MMC/SD Switching Characteristics	130
5-29 I ² C Signals (I2C.SDA and I2C.SCL) Switching Characteristics	132
5-30 USB Integrated Transceiver Interface Switching Characteristics	133
5-31 Microwire Timing Requirements	134
5-32 Microwire Switching Characteristics	134

1 OMAP5910 Features

- **Low-Power, High-Performance CMOS Technology**
 - 0.13- μ m Technology
 - 1.6-V Core Voltage
- **TI925T (MPU) ARM9TDMI™ Core**
 - Support 32-Bit and 16-Bit (Thumb® Mode) Instruction Sets
 - 16K-Byte Instruction Cache
 - 8K-Byte Data Cache
 - Data and Program Memory Management Units (MMUs)
 - Two 64-Entry Translation Look-Aside Buffers (TLBs) for MMUs
 - 17-Word Write Buffer
- **TMS320C55x™ (C55x™) DSP Core**
 - One/Two Instructions Executed per Cycle
 - Dual Multipliers (Two Multiply-Accumulates per Cycle)
 - Two Arithmetic/Logic Units
 - One Internal Program Bus
 - Five Internal Data/Operand Buses (3 Read Buses and 2 Write Buses)
 - 32K x 16-Bit On-Chip Dual-Access RAM (DARAM) (64K Bytes)
 - 48K x 16-Bit On-Chip Single-Access RAM (SARAM) (96K Bytes)
 - 16K x 16-Bit On-Chip ROM (32K Bytes)
 - Instruction Cache (24K Bytes)
 - Video Hardware Accelerators for DCT, iDCT, Pixel Interpolation, and Motion Estimation for Video Compression
- **192K Bytes of Shared Internal SRAM**
- **Memory Traffic Controller (TC)**
 - 16-Bit EMIFS External Memory Interface to Access up to 128M Bytes of Flash, ROM, or ASRAM
 - 16-Bit EMIFF External Memory Interface to Access up to 64M Bytes of SDRAM
- **9-Channel System DMA Controller**
- **DSP Memory Management Unit**
- **Endianism Conversion Logic**
- **Digital Phase-Locked Loop (DPLL) for MPU/DSP/TC Clocking Control**
- **DSP Peripherals**
 - Three 32-Bit Timers and Watchdog Timer
 - Level1/Level2 Interrupt Handlers
 - Six-Channel DMA Controller
 - Two Multichannel Buffered Serial Ports
 - Two Multichannel Serial Interfaces
- **TI925T Peripherals**
 - Three 32-Bit Timers and Watchdog Timer
 - 32-kHz Timer
 - Level1/Level2 Interrupt Handlers
 - USB1.1 Host Interface With up to 3 Ports
 - USB1.1 Function Interface
 - One Integrated USB Transceiver for Either Host or Function
 - Multichannel Buffered Serial Port
 - Inter-Integrated Circuit (I²C) Master and Slave Interface
 - Microwire™ Serial Interface
 - Multimedia Card (MMC) and Secure Digital (SD) Interface
 - HDQ/1-Wire® Interface
 - Camera Interface for CMOS Sensors
 - ETM9 Trace Module for TI925T Debug
 - Keyboard Matrix Interface (6 x 5 or 8 x 8)
 - Up to Ten MPU General-Purpose I/Os
 - Pulse-Width Tone (PWT) Interface
 - Pulse-Width Light (PWL) Interface
 - Two LED Pulse Generators (LPGs)
 - Real-Time Clock (RTC)
 - LCD Controller With Dedicated System DMA Channel
- **Shared Peripherals**
 - Three Universal Asynchronous Receiver/Transmitters (UARTs) (One Supporting SIR Mode for IrDA)
 - Four Interprocessor Mailboxes
 - Up to 14 Shared General-Purpose I/Os
- **Individual Power-Saving Modes for MPU/DSP/TC**
- **On-Chip Scan-Based Emulation Logic**
- **IEEE Std 1149.1† (JTAG) Boundary Scan Logic**
- **289-Ball MicroStar BGA™ (Ball Grid Array) (GZG Suffix)**

TMS320C55x, C55x, and MicroStar BGA are trademarks of Texas Instruments.

ARM9TDMI is a trademark of ARM Limited.

Thumb is a registered trademark of ARM Limited.

Microwire is a trademark of National Semiconductor Corporation.

1-Wire is a registered trademark of Dallas Semiconductor Corporation.

Other trademarks are the property of their respective owners.

† IEEE Standard 1149.1-1990 Standard Test-Access Port and Boundary Scan Architecture.

2 Introduction

This section describes the main features of the OMAP5910 device, lists the terminal assignments, and describes the function of each terminal. This data manual also provides a detailed description section, electrical specifications, parameter measurement information, and mechanical data about the available packaging.

2.1 Description

The OMAP5910 is a highly integrated hardware and software platform, designed to meet the application processing needs of next-generation embedded devices.

The OMAP™ platform enables OEMs and ODMs to quickly bring to market devices featuring rich user interfaces, high processing performance, and long battery life through the maximum flexibility of a fully integrated mixed processor solution.

The dual-core architecture provides benefits of both DSP and RISC technologies, incorporating a TMS320C55x DSP core and a high-performance TI925T ARM core.

The OMAP5910 device is designed to run leading open and embedded RISC-based operating systems, as well as the Texas Instruments (TI) DSP/BIOS™ software kernel foundation, and is available in a 289-ball MicroStar BGA package.

The OMAP5910 is targeted at the following applications:

- Applications processing devices
- Mobile communications
 - 802.11
 - Bluetooth™ wireless technology
 - GSM
 - GPRS
 - EDGE
 - CDMA
 - Proprietary government and other
- Video and image processing (MPEG4, JPEG, Windows® Media Video, etc.)
- Advanced speech applications (text-to-speech, speech recognition)
- Audio processing (MPEG-1 Audio Layer3 [MP3], AMR, WMA, AAC, and other GSM speech codecs)
- Graphics and video acceleration
- Generalized web access
- Data processing (fax, encryption/decryption, authentication, signature verification and watermarking)

2.1.1 TMS320C55x DSP Core

The DSP core of the OMAP5910 device is based on the TMS320C55x DSP generation CPU processor core. The C55x DSP architecture achieves high performance and low power through increased parallelism and total focus on reduction in power dissipation. The CPU supports an internal bus structure composed of one program bus, three data read buses, two data write buses, and additional buses dedicated to peripheral and DMA activity. These buses provide the ability to perform up to three data reads and two data writes in a single cycle. In parallel, the DMA controller can perform up to two data transfers per cycle independent of the CPU activity.

OMAP and DSP/BIOS are trademarks of Texas Instruments.
 Bluetooth is a trademark owned by Bluetooth SIG, Inc.
 Windows is a registered trademark of Microsoft Corporation.

The C55x CPU provides two multiply-accumulate (MAC) units, each capable of 17-bit x 17-bit multiplication in a single cycle. A central 40-bit arithmetic/logic unit (ALU) is supported by an additional 16-bit ALU. Use of the ALUs is under instruction set control, providing the ability to optimize parallel activity and power consumption. These resources are managed in the address unit (AU) and data unit (DU) of the C55x CPU.

The C55x DSP generation supports a variable byte width instruction set for improved code density. The instruction unit (IU) performs 32-bit program fetches from internal or external memory and queues instructions for the program unit (PU). The program unit decodes the instructions, directs tasks to AU and DU resources, and manages the fully protected pipeline. Predictive branching capability avoids pipeline flushes on execution of conditional instructions. The OMAP5910 DSP core also includes a 24K-byte instruction cache to minimize external memory accesses, improving data throughput and conserving system power.

2.1.1.1 DSP Tools Support

The 55x DSP core is supported by the industry's leading eXpressDSP™ software environment including the Code Composer Studio™ integrated development environment, DSP/BIOS software kernel foundation, the TMS320™ DSP Algorithm Standard, and the industry's largest third-party network. Code Composer Studio features code generation tools including a C-Compiler, Visual Linker, simulator, Real-Time Data Exchange (RTDX™), XDS510™ emulation device drivers, and Chip Support Libraries (CSL). DSP/BIOS is a scalable real-time software foundation available for no cost to users of Texas Instruments' DSP products providing a preemptive task scheduler and real-time analysis capabilities with very low memory and megahertz overhead. The TMS320 DSP Algorithm Standard is a specification of coding conventions allowing fast integration of algorithms from different teams, sites, or third parties into the application framework. Texas Instruments' extensive DSP third-party network of over 400 providers brings focused competencies and complete solutions to customers.

2.1.1.2 DSP Software Support

Texas Instruments has also developed foundation software available for the 55x DSP core. The C55x DSP Library (DSPLIB) features over 50 C-callable software kernels (FIR/IIR filters, Fast Fourier Transforms (FFTs), and various computational functions). The DSP Image/Video Processing Library (IMGLIB) contains over 20 software kernels highly optimized for C55x DSPs and is compiled with the latest revision of the C55x DSP code generation tools. These imaging functions support a wide range of applications that include compression, video processing, machine vision, and medical imaging.

2.1.2 TI-Enhanced TI925T RISC Processor

The MPU core is a TI925T reduced instruction set computer (RISC) processor. The TI925T is a 32-bit processor core that performs 32-bit or 16-bit instructions and processes 32-bit, 16-bit, or 8-bit data. The core uses pipelining so that all parts of the processor and memory system can operate continuously.

The MPU core incorporates:

- A coprocessor 15 (CP15) and protection module
- Data and program Memory Management Units (MMUs) with table look-aside buffers.
- A separate 16K-byte instruction cache and 8K-byte data cache. Both are two-way associative with virtual index virtual tag (VIVT).
- A 17-word write buffer (WB)

The OMAP5910 device uses the TI925T core in little endian mode only.

To reduce effective memory access time, the TI925T has an instruction cache, a data cache, and a write buffer. In general, these are transparent to program execution.

eXpressDSP, Code Composer Studio, TMS320, RTDX, and XDS510 are trademarks of Texas Instruments.

2.2 Terminal Assignments

Figure 2–1 illustrates the ball locations for the 289-ball ball grid array (BGA) package and is used in conjunction with Table 2–1 to locate signal names and ball grid numbers. BGA ball numbers in Table 2–1 are read from left-to-right, top-to-bottom.

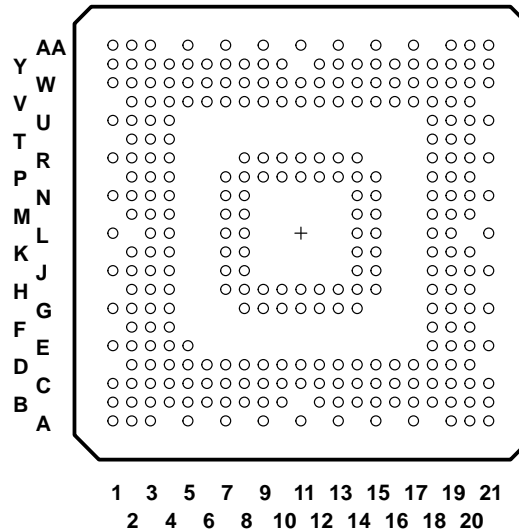

Figure 2–1. OMAP5910 GZG MicroStar BGA™ Package (Bottom View)

In Table 2–1, signals with multiplexed functions are highlighted in gray. Signals within a multiplexed pin name are separated with forward slashes as follows:

- **signal1/signal2/signal3** (for example, GPIO11/HDQ)

Signals which are associated with specific peripherals are denoted by using the peripheral name, followed by a period, and then the signal name; as follows:

- **peripheral1.signal1** (for example, MCBSP1.DR)

Table 2–1. Terminal Assignments

BGA BALL #	SIGNAL	BGA BALL #	SIGNAL	BGA BALL #	SIGNAL	BGA BALL #	SIGNAL
A1	DVDD4	A2	SDRAM.RAS	A3	CVDD1	A5	DVDD4
A7	DVDD4	A9	CVDD	A11	VSS	A13	VSS
A15	DVDD1	A17	LCD.P[13]	A19	DVDD1	A20	LCD.P[5]
A21	VSS	B1	VSS	B2	VSS	B3	SDRAM.DQML
B4	SDRAM.D[13]	B5	VSS	B6	SDRAM.D[8]	B7	VSS
B8	SDRAM.D[4]	B9	SDRAM.D[0]	B10	DVDD4	B12	DVDD4
B13	CVDD3	B14	SDRAM.A[0]	B15	LCD.AC	B16	VSS
B17	LCD.P[11]	B18	VSS	B19	LCD.P[6]	B20	CVDD3
B21	LCD.P[1]	C1	FLASH.A[3]	C2	DVDD5	C3	SDRAM.WE
C4	SDRAM.D[14]	C5	SDRAM.D[11]	C6	SDRAM.D[9]	C7	SDRAM.D[6]
C8	SDRAM.D[2]	C9	SDRAM.CLK	C10	SDRAM.BA[0]	C11	SDRAM.A[10]
C12	SDRAM.A[7]	C13	SDRAM.A[4]	C14	SDRAM.A[1]	C15	LCD.PCLK
C16	LCD.P[14]	C17	LCD.P[10]	C18	LCD.P[7]	C19	LCD.P[2]

Table 2–1. Terminal Assignments (Continued)

BGA BALL #	SIGNAL	BGA BALL #	SIGNAL	BGA BALL #	SIGNAL	BGA BALL #	SIGNAL
C20	KB.C[5]	C21	KB.C[4]	D2	FLASH.A[5]	D3	FLASH.A[2]
D4	SDRAM.DQMU	D5	SDRAM.D[15]	D6	SDRAM.D[12]	D7	SDRAM.D[7]
D8	SDRAM.D[5]	D9	SDRAM.CKE	D10	SDRAM.BA[1]	D11	SDRAM.A[9]
D12	SDRAM.A[6]	D13	SDRAM.A[3]	D14	LCD.VS	D15	LCD.P[15]
D16	LCD.P[9]	D17	LCD.P[8]	D18	LCD.P[0]	D19	KB.C[2]
D20	KB.C[1]	E1	DV _{DD5}	E2	V _{SS}	E3	FLASH.A[7]
E4	FLASH.A[4]	E5	RSVD	E18	KB.C[3]	E19	KB.R[4]
E20	KB.R[3]	E21	DV _{DD1}	F2	CV _{DD}	F3	FLASH.A[9]
F4	FLASH.A[6]	F18	KB.C[0]	F19	KB.R[1]	F20	V _{SS}
G1	V _{SS}	G2	FLASH.A[12]	G3	FLASH.A[11]	G4	FLASH.A[10]
G8	SDRAM.D[3]	G9	SDRAM.D[1]	G10	SDRAM.A[12]	G11	SDRAM.A[8]
G12	SDRAM.A[2]	G13	LCD.P[12]	G14	LCD.P[3]	G18	KB.R[0]
G19	PWRON_RESET	G20	MCBSP1.CLKS	G21	MCBSP1.CLKX	H2	DV _{DD5}
H3	FLASH.A[15]	H4	FLASH.A[14]	H7	FLASH.RDY	H8	SDRAM.D[10]
H9	SDRAM.CAS	H10	SDRAM.A[11]	H11	SDRAM.A[5]	H12	LCD.HS
H13	LCD.P[4]	H14	KB.R[2]	H15	MCBSP1.FSX/ MCBSP1.DX	H18	MCBSP1.DX/ MCBSP1.FSX
H19	CAM.EXCLK/ ETM.SYNC/ UWIRE.SDO	H20	MCBSP1.DR	J1	FLASH.A[20]	J2	FLASH.A[17]
J3	FLASH.A[19]	J4	FLASH.A[18]	J7	FLASH.A[8]	J8	FLASH.A[1]
J14	CAM.D[5]/ ETM.D[5]/ UWIRE.SDI	J15	CAM.LCLK/ ETM.CLK/ UWIRE.SCLK	J18	CAM.D[7]/ ETM.D[7]/ UWIRE.CS0	J19	CAM.D[6]/ ETM.D[6]/ UWIRE.CS3
J20	V _{SS}	J21	CV _{DD3}	K2	V _{SS}	K3	FLASH.A[23]
K4	FLASH.A[22]	K7	FLASH.A[16]	K8	FLASH.A[13]	K14	CAM.D[1]/ETM.D[1]/ UART3.RTS
K15	CAM.D[2]/ ETM.D[2]/ UART3.CTS	K18	CAM.D[4]/ ETM.D[4]/ UART3.TX	K19	CAM.D[3]/ ETM.D[3]/ UART3.RX	K20	V _{SS}
L1	DV _{DD5}	L3	FLASH.BE[0]	L4	FLASH.ADV	L7	FLASH.A[24]
L8	FLASH.A[21]	L14	UART3.RX/PWL/ UART2.RX	L15	CAM.HS/ ETM.PSTAT[1]/ UART2.CTS	L18	CAM.VS/ ETM.PSTAT[2]
L19	CAM.D[0]/ ETM.D[0]/ MPUIO12	L21	DV _{DD1}	M2	CV _{DD4}	M3	FLASH.CS1
M4	FLASH.CS2/ FLASH.BAA	M7	FLASH.CS0	M8	FLASH.BE[1]	M14	GPIO2/ SPI.CLK
M15	GPIO7/ MMC.DAT2	M18	UART3.TX/ PWT/ UART2.TX	M19	CAM.RSTZ/ ETM.PSTAT[0]/ UART2.RTS	M20	GPIO15/ KB.R[7]
N1	V _{SS}	N2	FLASH.D[1]	N3	FLASH.CLK	N4	FLASH.D[0]
N7	FLASH.D[2]	N8	FLASH.CS3	N14	UWIRE.CS0/ MCBSP3.CLKX	N15	MPUIO2/ EXT_DMA_REQ0
N18	GPIO12/ MCBSP3.FSX	N19	GPIO13/ KB.R[5]	N20	GPIO11/ HDQ	N21	GPIO14/ KB.R[6]
P2	FLASH.D[3]	P3	DV _{DD5}	P4	FLASH.D[4]	P7	FLASH.D[5]
P8	FLASH.D[11]	P9	USB0.DP	P10	MCBSP2.DR/ MCBSP2.DX	P11	MMC.CMD/SPI.DO

PRODUCT PREVIEW

Table 2–1. Terminal Assignments (Continued)

BGA BALL #	SIGNAL	BGA BALL #	SIGNAL	BGA BALL #	SIGNAL	BGA BALL #	SIGNAL
P12	CVDD	P13	CLK32K_IN	P14	RST_HOST_OUT/ MCBSP3.DX/ USB1.SE0	P15	UWIRE.CS3/ KB.C[6]
P18	GPIO3/ SPI.CS3/ MCBSP3.FSX/LED1	P19	GPIO6/ SPI.CS1/ MCBSP3.FSX	P20	GPIO4/ SPI.CS2/ MCBSP3.FSX	R1	DVDD5
R2	FLASH.D[6]	R3	FLASH.D[7]	R4	FLASH.D[8]	R8	USB.DM
R9	UART2.RX/ USB2.VM	R10	MCLKREQ/EXT_ MASTER_REQ	R11	MMC.DAT0/SPI.DI	R12	OSC32K_OUT
R13	BCLKREQ/ UART3.CTS/ UART1.DSR	R14	UART1.CTS	R18	GPIO0/ SPI.RDY/ USB.VBUS	R19	GPIO1/ UART3.RTS
R20	CVDD3	R21	VSS	T2	FLASH.D[9]	T3	FLASH.D[10]
T4	FLASH.D[14]	T18	I2C.SCL	T19	MPUIO4/ EXT_DMA_REQ1/ LED2	T20	MPUIO5/ LOW_PWR
U1	FLASH.D[12]	U2	VSS	U3	FLASH.D[13]	U4	FLASH.OE
U18	UWIRE.SDI/ UART3.DSR/ UART1.DSR/ MCBSP3.DR	U19	MPUIO1	U20	VSS	U21	DVDD1
V2	DVDD5	V3	FLASH.D[15]	V4	FLASH.WP	V5	VSS
V6	UART2.TX/ USB2.TXD	V7	MCBSP2.CLKR/ GPIO11	V8	MPUIO3	V9	MCSI2.SYNC/ GPIO7
V10	MMC.DAT1/ MPUIO7	V11	MMC.CLK	V12	VSS	V13	MCSI1.SYNC/ USB1.VP
V14	UART1.RX	V15	MPU_RST	V16	EMU0	V17	TMS
V18	CONF	V19	UWIRE.SCLK/ KB.C[7]	V20	I2C.SDA	W1	FLASH.RP
W2	FLASH.WE	W3	OSC1_OUT	W4	USB.PUEN/ USB.CLKO	W5	UART2.RTS/ USB2.SE0/ MPUIO5
W6	MCBSP2.FSR/ GPIO12	W7	MCBSP2.FSX	W8	GPIO9	W9	MCSI2.DOUT/ USB2.TXEN
W10	MMC.DAT2/ MPUIO11	W11	MMC.DAT3/ MPUIO6	W12	OSC32K_IN	W13	MCSI1.DIN/ USB1.RCV
W14	MCSI1.DOUT/ USB1.TXD	W15	RST_OUT	W16	MCBSP3.CLKX/ USB1.TXEN	W17	EMU1
W18	TCK	W19	BFAIL/ EXT_FIQ	W20	VSS	W21	UWIRE.SDO/ UART3.DTR/ UART1.DTR/ MCBSP3.DX
Y1	CVDD2	Y2	OSC1_IN	Y3	VSS	Y4	UART2.BCLK
Y5	UART2.CTS/ USB2.RCV/ GPIO7	Y6	MCBSP2.CLKX	Y7	DVDD3	Y8	GPIO8
Y9	MCLK	Y10	MCSI2.CLK/ USB2.SUSP	Y12	CLK32K_OUT/ MPUIO0/ USB1.SPEED	Y13	BCLK/ UART3.RTS/ UART1.DTR
Y14	UART1.TX	Y15	VSS	Y16	DVDD1	Y17	STAT_VAL/ WKUP
Y18	TRST	Y19	TDI	Y20	CVDD	Y21	CVDDA
AA1	VSS	AA2	DVDD2	AA3	CVDD2	AA5	MCBSP2.DX/ MCBSP2.DR

Table 2–1. Terminal Assignments (Continued)

BGA BALL #	SIGNAL	BGA BALL #	SIGNAL	BGA BALL #	SIGNAL	BGA BALL #	SIGNAL
AA7	V _{SS}	AA9	MCSI2.DIN/ USB2.VP	AA11	DV _{DD1}	AA13	MCSI1.CLK/ USB1.VM
AA15	UART1.RTS	AA17	MPU_BOOT/ MCBSP3.DR/ USB1.SUSP	AA19	TDO	AA20	CLK32K_CTRL
AA21	V _{SS}						

2.3 Terminal Characteristics and Multiplexing

Table 2–2 describes terminal characteristics and the signals multiplexed on each pin. The table column headers are explained below:

- **BALL:** Ball number(s) associated with each signal(s).
- **SIGNAL NAME:** The names of all the signals that are multiplexed on each ball.
- **TYPE:** The terminal type when a particular signal is multiplexed on the terminal.
- **MUX CTRL SETTING:** The register field that controls multiplexing on the terminal and the proper register field setting necessary to select the signal to be multiplexed on the terminal. The reset values of these register fields are indicated in bold type.
- **DESELECTED INPUT STATE:** The logic level internally driven to the signal when it is not selected to be multiplexed on the corresponding terminal.
- **PULLUP/PULLDN:** Denotes the presence of an internal pullup or pulldown. Pullups and pulldowns can be enabled or disabled via software.
- **BUFFER STRENGTH:** Drive strength of the associated output buffer.
- **OTHER:** Contains various terminal information, such as buffer type, boundary scan capability, and gating/inhibit functionality. [Certain terminals may be gated or 3-stated based on the state of other terminals and/or software configuration register settings.
- **RESET STATE:** The state of the terminal at reset.
- **SUPPLY:** The voltage supply which powers the terminal's I/O buffers.

NOTE: Due to the extensive pin multiplexing options which are available on the OMAP5910 device, a software utility is available to ease the process of configuring the pins based on the peripheral set required by a specific application. The 5910 OMAP Pin Configuration Utility is currently available from Texas Instruments.

NOTE: Configuring two pins to the same input signal is not supported as it can yield unexpected results. This can be easily avoided with proper software configuration.

Table 2–2. Terminal Characteristics and Multiplexing

BALL	SIGNAL NAME	TYPE†	MUX CTRL SETTING‡	DESELECTED INPUT STATE	PULLUP/PULLDN§	BUFFER STRENGTH	OTHER¶	RESET STATE#	SUPPLY
C3	SDRAM.WE	O/Z	NA	NA		4 mA	A, H2	1	DVDD4
A2	SDRAM.RAS	O/Z	NA	NA		4 mA	A, H2	1	DVDD4
D4	SDRAM.DQMU	O/Z	NA	NA		4 mA	A, H2	1	DVDD4
B3	SDRAM.DQML	O/Z	NA	NA		4 mA	A, H2	1	DVDD4
D5 C4 B4 D6 C5 H8 C6 B6 D7 C7 D8 B8 G8 C8 G9 B9	SDRAM.D[15:0]	I/O/Z	NA	NA		4 mA	E	0	DVDD4
D9	SDRAM.CKE	O/Z	NA	NA		4 mA	A, H2	1	DVDD4
C9	SDRAM.CLK	I/O/Z	NA	NA		8 mA	E, H2	LZ	DVDD4
H9	SDRAM.CAS	O/Z	NA	NA		4 mA	A, H2	1	DVDD4
D10 C10	SDRAM.BA[1:0]	O/Z	NA	NA		4 mA	A, H2	0	DVDD4
G10 H10 C11 D11 G11 C12 D12 H11 C13 D13 G12 C14 B14	SDRAM.A[12:0]	O/Z	NA	NA		4 mA	A, H2	0	DVDD4
D14	LCD.VS	O	NA	NA		4 mA	J, A, G1	0	DVDD1
H12	LCD.HS	O	NA	NA		4 mA	J, A, G1	0	DVDD1
B15	LCD.AC	O	NA	NA		4 mA	J, A, G1	0	DVDD1
C15	LCD.PCLK	O	NA	NA		4 mA	J, A, G1	0	DVDD1

† I = Input, O = Output, Z = High-Impedance

‡ 'regx' denotes the terminal multiplexing register that controls the specified terminal where regx = FUNC_MUX_CTRL_x

§ PD20 = 20- μ A internal pulldown, PD100 = 100- μ A pulldown, PU20 = 20- μ A internal pullup, PU100 = 100- μ A internal pullup

¶ A = Standard LVCMOS input/output

G1 = Terminal may be gated by BFAIL

B = Fail-safe LVCMOS input/output

G2 = Terminal may be gated by GPIO9 and MPUIO3

C = USB transceiver input/output

G3 = Terminal may be gated by BFAIL and PWRON_RESET

D = I²C input/output buffers

H1 = Terminal may be 3-stated by BFAIL input

E = Fail-safe LVCMOS input and Standard LVCMOS output

H2 = Terminal may be 3-stated via software configuration

F = analog oscillator terminals

J = Boundary-scannable terminal

Z = High-Impedance, LZ = Low-Impedance (pin is driven), 1 = Output driven high, 0 = Output driven low

|| UART1 signals can be multiplexed to this pin via additional multiplexing in the USB module.

Table 2–2. Terminal Characteristics and Multiplexing (Continued)

BALL	SIGNAL NAME	TYPE†	MUX CTRL SETTING‡	DESELECTED INPUT STATE	PULLUP/PULLDN§	BUFFER STRENGTH	OTHER¶	RESET STATE#	SUPPLY
D15 C16 A17 G13 B17 C17 D16 D17 C18 B19 A20 H13 G14 C19 B21 D18	LCD.P[15:0]	O	NA	NA		4 mA	J, A, G1	0	DV _{DD1}
C20 C21 E18 D19 D20 F18	KB.C[5:0]	O	NA	NA		4 mA	A, J	0	DV _{DD1}
E19 E20 H14 F19 G18	KB.R[4:0]	I	NA	NA			A, J	input	DV _{DD1}
G19	PWRON_RESET	I	NA	NA			B, J	input	DV _{DD1}
G20	MCBSP1.CLKS	I	NA	NA			B, J	input	DV _{DD1}
G21	MCBSP1.CLKX	I/O/Z	NA	NA		4 mA	J, B, G1	Z	DV _{DD1}
H15	MCBSP1.FSX	I/O/Z	reg4[14:12] = 000	0		4 mA	J, B, G1	Z	DV _{DD1}
	MCBSP1.DX	O	reg4[14:12] = 001	NA					
H18	MCBSP1.DX	O	reg4[17:15] = 000	NA		4 mA	J, B, G1	0	DV _{DD1}
	MCBSP1.FSX	I/O/Z	reg4[17:15] = 001	0					
H20	MCBSP1.DR	I	NA	NA	PD20		B, J	input	DV _{DD1}
H19	CAM.EXCLK	O	reg4[23:21] = 000	NA		8 mA	J, A, G1	0	DV _{DD1}
	ETM.SYNC	O	reg4[23:21] = 001	NA					
	UWIRE.SDO	O	reg4[23:21] = 010	NA					
J15	CAM.LCLK	I	reg4[26:24] = 000	0		8 mA	B, J	input	DV _{DD1}
	ETM.CLK	O	reg4[26:24] = 001	NA					
	UWIRE.SCLK	O	reg4[26:24] = 010	NA					

† I = Input, O = Output, Z = High-Impedance

‡ 'regx' denotes the terminal multiplexing register that controls the specified terminal where regx = FUNC_MUX_CTRL_x

§ PD20 = 20- μ A internal pulldown, PD100 = 100- μ A pulldown, PU20 = 20- μ A internal pullup, PU100 = 100- μ A internal pullup

¶ A = Standard LVCMOS input/output

G1 = Terminal may be gated by BFAIL

B = Fail-safe LVCMOS input/output

G2 = Terminal may be gated by GPIO9 and MPUIO3

C = USB transceiver input/output

G3 = Terminal may be gated by BFAIL and PWRON_RESET

D = I²C input/output buffers

H1 = Terminal may be 3-stated by BFAIL input

E = Fail-safe LVCMOS input and Standard LVCMOS output

H2 = Terminal may be 3-stated via software configuration

F = analog oscillator terminals

J = Boundary-scannable terminal

Z = High-Impedance, LZ = Low-Impedance (pin is driven), 1 = Output driven high, 0 = Output driven low

|| UART1 signals can be multiplexed to this pin via additional multiplexing in the USB module.

Table 2–2. Terminal Characteristics and Multiplexing (Continued)

BALL	SIGNAL NAME	TYPE†	MUX CTRL SETTING‡	DESELECTED INPUT STATE	PULLUP/PULLDN§	BUFFER STRENGTH	OTHER¶	RESET STATE#	SUPPLY
J18	CAM.D[7]	I	reg4[29:27] = 000	NA		8 mA	B, J	input	DVDD1
	ETM.D[7]	O	reg4[29:27] = 001	NA					
	UWIRE.CS0	O	reg4[29:27] = 010	NA					
J19	CAM.D[6]	I	reg5[2:0] = 000	NA		8 mA	B, J	input	DVDD1
	ETM.D[6]	O	reg5[2:0] = 001	NA					
	UWIRE.CS3	O	reg5[2:0] = 010	NA					
J14	CAM.D[5]	I	reg5[5:3] = 000	NA		8 mA	B, J	input	DVDD1
	ETM.D[5]	O	reg5[5:3] = 001	NA					
	UWIRE.SDI	I	reg5[5:3] = 010	NA	PD20				
K18	CAM.D[4]	I	reg5[8:6] = 000	NA		8 mA	B, J	input	DVDD8
	ETM.D[4]	O	reg5[8:6] = 001	NA					
	UART3.TX	O	reg5[8:6] = 010	NA					
K19	CAM.D[3]	I	reg5[11:9] = 000	NA		8 mA	B, J	input	DVDD1
	ETM.D[3]	O	reg5[11:9] = 001	NA					
	UART3.RX	I	reg5[11:9] = 010	NA	PD20				
K15	CAM.D[2]	I	reg5[14:12] = 000	NA		8 mA	B, J	input	DVDD1
	ETM.D[2]	O	reg5[14:12] = 001	NA					
	UART3.CTS	I	reg5[14:12] = 010	NA	PD20				
K14	CAM.D[1]	I	reg5[17:15] = 000	NA		8 mA	B, J	input	DVDD1
	ETM.D[1]	O	reg5[17:15] = 001	NA					
	UART3.RTS	O	reg5[17:15] = 010	NA					
L19	CAM.D[0]	I	reg5[20:18] = 000	NA		8 mA	B, J	input	DVDD1
	ETM.D[0]	O	reg5[20:18] = 001	NA					
	MPIUIO12	I/O/Z	reg5[20:18] = 010	NA					
L18	CAM.VS	I	reg5[23:21] = 000	NA		8 mA	B, J	input	DVDD1
	ETM.PSTAT[2]	O	reg5[23:21] = 001	NA					
L15	CAM.HS	I	reg5[26:24] = 000	NA		8 mA	B, J	input	DVDD1
	ETM.PSTAT[1]	O	reg5[26:24] = 001	NA					
	UART2.CTS	I	reg5[26:24] = 010	NA	PD20				
M19	CAM.RSTZ	O	reg5[29:27] = 000	NA		8 mA	J, B, G1	0	DVDD1
	ETM.PSTAT[0]	O	reg5[29:27] = 001	NA					
	UART2.RTS	O	reg5[29:27] = 010	NA					

† I = Input, O = Output, Z = High-Impedance

‡ 'regx' denotes the terminal multiplexing register that controls the specified terminal where regx = FUNC_MUX_CTRL_x

§ PD20 = 20- μ A internal pulldown, PD100 = 100- μ A pulldown, PU20 = 20- μ A internal pullup, PU100 = 100- μ A internal pullup

¶ A = Standard LVCMOS input/output

B = Fail-safe LVCMOS input/output

C = USB transceiver input/output

D = I²C input/output buffers

E = Fail-safe LVCMOS input and Standard LVCMOS output

F = analog oscillator terminals

G1 = Terminal may be gated by BFAIL

G2 = Terminal may be gated by GPIO9 and MPIUIO3

G3 = Terminal may be gated by BFAIL and PWRON_RESET

H1 = Terminal may be 3-stated by BFAIL input

H2 = Terminal may be 3-stated via software configuration

J = Boundary-scannable terminal

Z = High-Impedance, LZ = Low-Impedance (pin is driven), 1 = Output driven high, 0 = Output driven low

|| UART1 signals can be multiplexed to this pin via additional multiplexing in the USB module.

Table 2–2. Terminal Characteristics and Multiplexing (Continued)

BALL	SIGNAL NAME	TYPE†	MUX CTRL SETTING‡	DESELECTED INPUT STATE	PULLUP/PULLDN§	BUFFER STRENGTH	OTHER¶	RESET STATE#	SUPPLY
M18	<i>pin forced to drive low</i>	O	reg6[2:0] = 000	NA		4 mA	J, A, G1	0	DV _{DD1}
	UART3.TX	O	reg6[2:0] = 001	NA					
	PWT	O	reg6[2:0] = 010	NA					
	IRQ_OBS	O	reg6[2:0] = 011	NA					
	UART2.TX	O	reg6[2:0] = 100	NA					
L14	UART3.RX	I	reg6[5:3] = 000	1		4 mA	B, J	input	DV _{DD1}
	PWL	O	reg6[5:3] = 001	NA					
	DMA_REQ_OBS	O	reg6[5:3] = 010	NA					
	UART2.RX	I	reg6[5:3] = 011	NA					
M20	GPIO15	I/O/Z	reg6[8:6] = 000	NA	PD20	4 mA	J, B, G1	Z	DV _{DD1}
	KB.R[7]	I	reg6[8:6] = 001	1					
N21	GPIO14	I/O/Z	reg6[11:9] = 000	NA	PD20	4 mA	J, B, G1	Z	DV _{DD1}
	KB.R[6]	I	reg6[11:9] = 001	1					
N19	GPIO13	I/O/Z	reg6[14:12] = 000	NA	PD20	4 mA	J, B, G1	Z	DV _{DD1}
	KB.R[5]	I	reg6[14:12] = 001	1					
N18	GPIO12	I/O/Z	reg6[17:15] = 000	NA	PD20	4 mA	J, B, G1	Z	DV _{DD1}
	MCBSP3.FSX	I/O/Z	reg6[17:15] = 001	0	PD20				
N20	GPIO11	I/O/Z	reg6[20:18] = 000	NA	PD20	4 mA	J, B, G1	Z	DV _{DD1}
	HDQ	I/O	reg6[20:18] = 001	NA	PD20				
M15	GPIO7	I/O/Z	reg6[23:21] = 000	NA	PD20	4 mA	J, B, G1	Z	DV _{DD1}
	MMC.DAT2	I/O/Z	reg6[23:21] = 001	1					
P19	GPIO6	I/O/Z	reg6[26:24] = 000	NA	PD20	4 mA	J, B, G1	Z	DV _{DD1}
	SPI.CS1	O	reg6[26:24] = 001	NA					
	MCBSP3.FSX	I/O/Z	reg6[26:24] = 010	NA	PD20				
P20	GPIO4	I/O/Z	reg6[29:27] = 000	NA	PD20	4 mA	J, B, G1	Z	DV _{DD1}
	SPI.CS2	O	reg6[29:27] = 001	NA					
	MCBSP3.FSX	I/O/Z	reg6[29:27] = 010	NA	PD20				
P18	GPIO3	I/O/Z	reg7[2:0] = 000	NA	PD20	4 mA	J, B, G1	Z	DV _{DD1}
	SPI.CS3	O	reg7[2:0] = 001	NA					
	MCBSP3.FSX	I/O/Z	reg7[2:0] = 010	NA	PD20				
	LED1	O	reg7[2:0] = 011	NA					

† I = Input, O = Output, Z = High-Impedance

‡ 'regx' denotes the terminal multiplexing register that controls the specified terminal where regx = FUNC_MUX_CTRL_x

§ PD20 = 20- μ A internal pulldown, PD100 = 100- μ A pulldown, PU20 = 20- μ A internal pullup, PU100 = 100- μ A internal pullup

¶ A = Standard LVCMOS input/output

G1 = Terminal may be gated by BFAIL

B = Fail-safe LVCMOS input/output

G2 = Terminal may be gated by GPIO9 and MPUIO3

C = USB transceiver input/output

G3 = Terminal may be gated by BFAIL and PWRON_RESET

D = I²C input/output buffers

H1 = Terminal may be 3-stated by BFAIL input

E = Fail-safe LVCMOS input and Standard LVCMOS output

H2 = Terminal may be 3-stated via software configuration

F = analog oscillator terminals

J = Boundary-scannable terminal

Z = High-Impedance, LZ = Low-Impedance (pin is driven), 1 = Output driven high, 0 = Output driven low

|| UART1 signals can be multiplexed to this pin via additional multiplexing in the USB module.

Table 2–2. Terminal Characteristics and Multiplexing (Continued)

BALL	SIGNAL NAME	TYPE†	MUX CTRL SETTING‡	DESELECTED INPUT STATE	PULLUP/PULLDN§	BUFFER STRENGTH	OTHER¶	RESET STATE#	SUPPLY
M14	GPIO2	I/O/Z	reg7[5:3] = 000	NA	PD20	4 mA	J, B, G1	Z	DVDD1
	SPI.CLK	O	reg7[5:3] = 001	NA					
R19	GPIO1	I/O/Z	reg7[8:6] = 000	NA	PD20	4 mA	J, B, G1	Z	DVDD1
	UART3.RTS	O	reg7[8:6] = 001	NA					
R18	GPIO0	I/O/Z	reg7[11:9] = 000	NA	PD20	4 mA	J, B, G1	Z	DVDD1
	SPI.RDY	I	reg7[11:9] = 001	NA					
	USB.VBUS	I	reg7[11:9] = 010	0	PD20				
T20	MPUIO5	I/O/Z	reg7[14:12] = 000	NA	PD20	4 mA	J, B, G1	Z	DVDD1
	LOW_PWR	O	reg7[14:12] = 001	NA					
T19	MPUIO4	I/O/Z	reg7[17:15] = 000	NA	PD20	4 mA	J, B, G1	Z	DVDD1
	EXT_DMA_REQ1	I	reg7[17:15] = 001	NA					
	LED2	O	reg7[17:15] = 010	NA					
N15	MPUIO2	I/O/Z	reg7[20:18] = 000	NA	PD20	4 mA	J, B, G1	Z	DVDD1
	EXT_DMA_REQ0	I	reg7[20:18] = 001	NA					
U19	MPUIO1	I/O/Z	NA	NA		4 mA	B, J	0	DVDD1
T18	I2C.SCL	I/O/Z	NA	NA		6 mA	J, D, H1	Z	DVDD1
V20	I2C.SDA	I/O/Z	NA	NA		6 mA	J, D, H1	Z	DVDD1
U18	UWIRE.SDI	I	reg8[2:0] = 000	NA	PD20	4 mA	B, J	input	DVDD1
	UART3.DSR	I	reg8[2:0] = 001	1	PD20				
	UART1.DSR	I	reg8[2:0] = 010	1	PD20				
	MCBSP3.DR	I	reg8[2:0] = 011	NA	PD20				
W21	UWIRE.SDO	O	reg8[5:3] = 000	NA		4 mA	J, A, G1	0	DVDD1
	UART3.DTR	O	reg8[5:3] = 001	NA					
	UART1.DTR	O	reg8[5:3] = 010	NA					
	MCBSP3.DX	O	reg8[5:3] = 011	NA					
V19	UWIRE.SCLK	O	reg8[8:6] = 000	NA		4 mA	J, A, G1	0	DVDD1
	KB.C[7]	O	reg8[8:6] = 001	NA					
N14	pin forced to high-z	Z	reg8[11:9] = 000	NA		4 mA	J, A	Z	DVDD1
	UWIRE.CS0	O	reg8[11:9] = 001	NA					
	MCBSP3.CLKX	I/O/Z	reg8[11:9] = 010	NA					

† I = Input, O = Output, Z = High-Impedance

‡ 'regx' denotes the terminal multiplexing register that controls the specified terminal where regx = FUNC_MUX_CTRL_x

§ PD20 = 20- μ A internal pulldown, PD100 = 100- μ A pulldown, PU20 = 20- μ A internal pullup, PU100 = 100- μ A internal pullup

¶ A = Standard LVCMOS input/output

G1 = Terminal may be gated by BFAIL

B = Fail-safe LVCMOS input/output

G2 = Terminal may be gated by GPIO9 and MPUIO3

C = USB transceiver input/output

G3 = Terminal may be gated by BFAIL and PWRON_RESET

D = I²C input/output buffers

H1 = Terminal may be 3-stated by BFAIL input

E = Fail-safe LVCMOS input and Standard LVCMOS output

H2 = Terminal may be 3-stated via software configuration

F = analog oscillator terminals

J = Boundary-scannable terminal

Z = High-Impedance, LZ = Low-Impedance (pin is driven), 1 = Output driven high, 0 = Output driven low

|| UART1 signals can be multiplexed to this pin via additional multiplexing in the USB module.

Table 2–2. Terminal Characteristics and Multiplexing (Continued)

BALL	SIGNAL NAME	TYPE†	MUX CTRL SETTING‡	DESELECTED INPUT STATE	PULLUP/PULLDN§	BUFFER STRENGTH	OTHER¶	RESET STATE#	SUPPLY
P15	<i>pin forced to high-z</i>	Z	reg8[14:12] = 000	NA		4 mA	J, A	Z	DVDD1
	UWIRE_CS3	O	reg8[14:12] = 001	NA					
	KB.C[6]	O	reg8[14:12] = 010	NA					
W19	BFAIL/EXT_FIQ	I	NA	NA			J, B	input	DVDD1
AA20	CLK32K_CTRL	I	NA	NA			J, B	input	DVDD1
V18	CONF	I	NA	NA	PD100		A	input	DVDD1
Y19	TDI	I	NA	NA	PD20		B	input	DVDD1
AA19	TDO	O	NA	NA		4 mA	A	0	DVDD1
V17	TMS	I	NA	NA	PD20		B	input	DVDD1
W18	TCK	I	NA	NA	PD20		B	input	DVDD1
Y18	TRST	I	NA	NA	PD100		B	input	DVDD1
V16	EMU0	I/O/Z	NA	NA	PU100	2 mA	B	Z	DVDD1
W17	EMU1	I/O/Z	NA	NA	PU100	2 mA	B	Z	DVDD1
Y17	STAT_VAL/WKUP	I	NA	NA			A	input	DVDD1
AA17	MPU_BOOT	I	reg8[29:27] = 000	NA	PD20	4 mA	J, B	input	DVDD1
	MCBSP3_DR	I	reg8[29:27] = 001	NA	PD20				
	USB1_SUSP	O	reg8[29:27] = 010	NA					
P14	RST_HOST_OUT	O	reg9[2:0] = 000	NA		4 mA	J, A, G1	0	DVDD1
	MCBSP3_DX	O	reg9[2:0] = 001	NA					
	USB1_SE0	O	reg9[2:0] = 010	NA					
W16	<i>pin forced to high-z</i>	Z	reg9[5:3] = 000	NA	PD20	4 mA	J, A, G1	Z	DVDD1
	MCBSP3_CLKX	I/O/Z	reg9[5:3] = 001	NA	PD20				
	USB1_TXEN	O	reg9[5:3] = 010	NA					
V15	MPU_RST	I	NA	NA			J, B	input	DVDD1
W15	RST_OUT	O	NA	NA		4 mA	J, A	0	DVDD1
AA15	<i>pin forced to drive low</i>	O	reg9[14:12] = 000	NA		2 mA	J, A, G1	0	DVDD1
	UART1.RTS	O	reg9[14:12] = 001	NA					
R14	UART1.CTS	I	NA	NA	PD20		J, B	input	DVDD1
V14	UART1.RX	I	NA	NA	PD20		J, B	input	DVDD1

† I = Input, O = Output, Z = High-Impedance

‡ 'regx' denotes the terminal multiplexing register that controls the specified terminal where regx = FUNC_MUX_CTRL_x

§ PD20 = 20- μ A internal pulldown, PD100 = 100- μ A pulldown, PU20 = 20- μ A internal pullup, PU100 = 100- μ A internal pullup

¶ A = Standard LVCMOS input/output

G1 = Terminal may be gated by BFAIL

B = Fail-safe LVCMOS input/output

G2 = Terminal may be gated by GPIO9 and MPUIO3

C = USB transceiver input/output

G3 = Terminal may be gated by BFAIL and PWRON_RESET

D = I²C input/output buffers

H1 = Terminal may be 3-stated by BFAIL input

E = Fail-safe LVCMOS input and Standard LVCMOS output

H2 = Terminal may be 3-stated via software configuration

F = analog oscillator terminals

J = Boundary-scannable terminal

Z = High-Impedance, LZ = Low-Impedance (pin is driven), 1 = Output driven high, 0 = Output driven low

|| UART1 signals can be multiplexed to this pin via additional multiplexing in the USB module.

Table 2–2. Terminal Characteristics and Multiplexing (Continued)

BALL	SIGNAL NAME	TYPE†	MUX CTRL SETTING‡	DESELECTED INPUT STATE	PULLUP/PULLDN§	BUFFER STRENGTH	OTHER¶	RESET STATE#	SUPPLY
Y14	<i>pin forced to drive low</i>	O	reg9[23:21] = 000	NA		2 mA	J, A, G1	0	DVDD1
	UART1.TX	O	reg9[23:21] = 001	NA					
W14	MCS11.DOUT	O	reg9[26:24] = 000	NA		2 mA	J, A, G1, H1	0	DVDD1
	USB1.TXD	O	reg9[26:24] = 001	NA					
	UART1.TX	O	reg9[26:24] = 001	NA					
R13	BCLKREQ	I	reg9[29:27] = 000	0	PD20		J, B	input	DVDD1
	UART3.CTS	I	reg9[29:27] = 001	0	PD20				
	UART1.DSR	I	reg9[29:27] = 010	1	PD20				
Y13	BCLK	O	regA[2:0] = 000	NA		4 mA	J, A, G1	0	DVDD1
	UART3.RTS	O	regA[2:0] = 001	NA					
	UART1.DTR	O	regA[2:0] = 010	NA					
V13	MCS11.SYNC	I/O/Z	regA[5:3] = 000	0	PD20	2 mA	J, B, G1	Z	DVDD1
	USB1.VP	I	regA[5:3] = 001	NA	PD20				
AA13	MCS11.CLK	I/O/Z	regA[8:6] = 000	0	PD20	2 mA	J, B, G1	Z	DVDD1
	USB1.VM	I	regA[8:6] = 001	0	PD20				
	UART1.RX	I	regA[8:6] = 001	0	PD20				
W13	MCS11.DIN	I	regA[11:9] = 000	NA	PD20		J, B	input	DVDD1
	USB1.RCV	I	regA[11:9] = 001	0	PD20				
	UART1.CTS	I	regA[11:9] = 001	0	PD20				
Y12	CLK32K_OUT	O	regA[14:12] = 000	NA		8 mA	J, A	LZ	DVDD1
	MPUIO0	I/O/Z	regA[14:12] = 001	NA					
	USB1.SPEED	O	regA[14:12] = 010	NA					
P13	CLK32K_IN	I	NA	NA			J, B	input	DVDD1
W12	OSC32K_IN	–	NA	NA			F	NA	NA
R12	OSC32K_OUT	–	NA	NA			F	NA	NA
W11	MMC.DAT3	I/O/Z	regD[14:12] = 000	1	PU20	4 mA	J, B, G1	Z	DVDD1
	<i>Reserved</i>	NA	regD[14:12] = 001	NA					
	MPUIO6	I/O/Z	regD[14:12] = 010	NA	PU20				
V11	MMC.CLK	O	NA	NA		4 mA	J, A, G1	0	DVDD1
R11	MMC.DAT0/SPI.DI	I/O/Z	NA	NA	PU20	4 mA	J, B, G1	Z	DVDD1
W10	MMC.DAT2	I/O/Z	regA[20:18] = 000	1	PU20	4 mA	J, B, G1	Z	DVDD1
	<i>pin forced to hi-z</i>	Z	regA[20:18] = 001	NA					
	MPUIO11	I/O/Z	regA[20:18] = 010	NA	PU20				

† I = Input, O = Output, Z = High-Impedance

‡ 'regx' denotes the terminal multiplexing register that controls the specified terminal where regx = FUNC_MUX_CTRL_x

§ PD20 = 20- μ A internal pulldown, PD100 = 100- μ A pulldown, PU20 = 20- μ A internal pullup, PU100 = 100- μ A internal pullup

¶ A = Standard LVCMOS input/output

G1 = Terminal may be gated by BFAIL

B = Fail-safe LVCMOS input/output

G2 = Terminal may be gated by GPIO9 and MPUIO3

C = USB transceiver input/output

G3 = Terminal may be gated by BFAIL and PWRON_RESET

D = I²C input/output buffers

H1 = Terminal may be 3-stated by BFAIL input

E = Fail-safe LVCMOS input and Standard LVCMOS output

H2 = Terminal may be 3-stated via software configuration

F = analog oscillator terminals

J = Boundary-scannable terminal

Z = High-Impedance, LZ = Low-Impedance (pin is driven), 1 = Output driven high, 0 = Output driven low

|| UART1 signals can be multiplexed to this pin via additional multiplexing in the USB module.

Table 2–2. Terminal Characteristics and Multiplexing (Continued)

BALL	SIGNAL NAME	TYPE†	MUX CTRL SETTING‡	DESELECTED INPUT STATE	PULLUP/PULLDN§	BUFFER STRENGTH	OTHER¶	RESET STATE#	SUPPLY
V10	MMC.DAT1	I/O/Z	regA[26:24] = 000	1	PU20	4 mA	J, B, G1	Z	DV _{DD1}
	<i>Reserved</i>	NA	regA[26:24] = 001	NA					
	MPUIO7	I/O/Z	regA[26:24] = 010	NA	PU20				
P11	MMC.CMD/SPI.DO	I/O/Z	NA	NA	PU100	4 mA	J, B, G1	Z	DV _{DD1}
Y10	MCSI2.CLK	I/O/Z	regB[5:3] = 000	0	PD20	4 mA	J, E	Z	DV _{DD3}
	USB2.SUSP	O	regB[5:3] = 001	NA					
AA9	MCSI2.DIN	I	regB[8:6] = 000	NA	PD20		J, B	input	DV _{DD3}
	USB2.VP	I	regB[8:6] = 001	0	PD20				
W9	MCSI2.DOUT	O	regB[11:9] = 000	NA		4 mA	J, A, G2	0	DV _{DD3}
	USB2.TXEN	O	regB[11:9] = 001	NA					
V9	MCSI2.SYNC	I/O/Z	regB[14:12] = 000	0	PD20	4 mA	J, E	Z	DV _{DD3}
	GPIO7	I/O/Z	regB[14:12] = 001	NA	PD20				
Y9	MCLK	O	NA	NA		4 mA	J, A, G1	0	DV _{DD3}
R10	MCLKREQ	I	regB[20:18] = 000	0	PD20	4 mA	J, E	input	DV _{DD3}
	EXT_MASTER_REQ	O	regB[20:18] = 001	NA					
W8	GPIO9	I/O/Z	NA	NA	PD20	4 mA	J, E, G3	Z	DV _{DD3}
Y8	GPIO8	I/O/Z	NA	NA	PD20	4 mA	J, E, G3	Z	DV _{DD3}
V8	MPUIO3	I/O/Z	NA	NA	PD20	4 mA	J, E, G1	Z	DV _{DD3}
P10	MCBSP2.DR	I	regC[2:0] = 000	NA	PD20	4 mA	J, B, G2	input	DV _{DD3}
	MCBSP2.DX	O	regC[2:0] = 001	NA					
W7	MCBSP2.FSX	I/O/Z	NA	0	PD20	4 mA	J, E, G2	Z	DV _{DD3}
V7	MCBSP2.CLKR	I/O/Z	regC[8:6] = 000	0		4 mA	J, E	Z	DV _{DD3}
	GPIO11	I/O/Z	regC[8:6] = 001	NA	PD20				
Y6	MCBSP2.CLKX	I/O/Z	NA	NA	PD20	4 mA	J, E, G2	Z	DV _{DD3}
W6	MCBSP2.FSR	I/O/Z	regC[14:12] = 000	0		4 mA	J, E	Z	DV _{DD3}
	GPIO12	I/O/Z	regC[14:12] = 001	NA	PD20				
AA5	MCBSP2.DX	O	regC[17:15] = 000	NA		4 mA	J, E, G2	0	DV _{DD3}
	MCBSP2.DR	I	regC[17:15] = 001	NA	PD20				
R9	UART2.RX	I	regC[20:18] = 000	1	PD20	4 mA	J, B	input	DV _{DD3}
	USB2.VM	I	regC[20:18] = 001	0	PD20				
Y5	UART2.CTS	I	regC[23:21] = 000	1	PD20	4 mA	J, B	input	DV _{DD3}
	USB2.RCV	I	regC[23:21] = 001	0	PD20		J, B		
	GPIO7	I/O/Z	regC[23:21] = 010	NA	PD20		J, E		

† I = Input, O = Output, Z = High-Impedance

‡ 'regx' denotes the terminal multiplexing register that controls the specified terminal where regx = FUNC_MUX_CTRL_x

§ PD20 = 20- μ A internal pulldown, PD100 = 100- μ A pulldown, PU20 = 20- μ A internal pullup, PU100 = 100- μ A internal pullup

¶ A = Standard LVCMOS input/output

B = Fail-safe LVCMOS input/output

C = USB transceiver input/output

D = I²C input/output buffers

E = Fail-safe LVCMOS input and Standard LVCMOS output

F = analog oscillator terminals

G1 = Terminal may be gated by BFAIL

G2 = Terminal may be gated by GPIO9 and MPUIO3

G3 = Terminal may be gated by BFAIL and PWRON_RESET

H1 = Terminal may be 3-stated by BFAIL input

H2 = Terminal may be 3-stated via software configuration

J = Boundary-scannable terminal

Z = High-Impedance, LZ = Low-Impedance (pin is driven), 1 = Output driven high, 0 = Output driven low

|| UART1 signals can be multiplexed to this pin via additional multiplexing in the USB module.

Table 2–2. Terminal Characteristics and Multiplexing (Continued)

BALL	SIGNAL NAME	TYPE†	MUX CTRL SETTING‡	DESELECTED INPUT STATE	PULLUP/PULLDN§	BUFFER STRENGTH	OTHER¶	RESET STATE#	SUPPLY
W5	<i>pin forced to drive low</i>	O	regC[26:24] = 000	NA		4 mA	J, E, G2	0	DV _{DD3}
	UART2.RTS	O	regC[26:24] = 001	NA					
	USB2.SE0	O	regC[26:24] = 010	NA					
	MPUIO5	I/O/Z	regC[26:24] = 011	NA					
V6	<i>pin forced to drive low</i>	O	regC[29:27] = 000	NA		4 mA	J, A, G2	0	DV _{DD3}
	UART2.TX	O	regC[29:27] = 001	NA					
	USB2.TXD	O	regC[29:27] = 010	NA					
Y4	UART2.BCLK	O	NA	NA		4 mA	J, A, G2	0	DV _{DD3}
W4	USB.PUEN	O	regD[5:3] = 000	NA		8 mA	J, B, G1	0	DV _{DD2}
	USB.CLKO	O	regD[5:3] = 001	NA					
P9	USB.DP	I/O/Z	NA	NA		18.3 mA	C	Z	DV _{DD2}
R8	USB.DM	I/O/Z	NA	NA		18.3 mA	C	Z	DV _{DD2}
Y2	OSC1_IN	–	NA	NA			F	NA	NA
W3	OSC1_OUT	–	NA	NA			F	NA	NA
V4	FLASH.WP	O/Z	NA	NA		4 mA	A, H2	0	DV _{DD5}
W2	FLASH.WE	O/Z	NA	NA		4 mA	A, H2	1	DV _{DD5}
W1	FLASH.RP	O/Z	NA	NA		4 mA	A, H2	0	DV _{DD5}
U4	FLASH.OE	O/Z	NA	NA		4 mA	A, H2	1	DV _{DD5}
V3 T4 U3 U1 P8 T3 T2 R4 R3 R2 P7 P4 P2 N7 N2 N4	FLASH.D[15:0]	I/O/Z	NA	NA		4 mA	E	0	DV _{DD5}
N3	FLASH.CLK	O/Z	NA	NA		8 mA	E, G1, H2	0	DV _{DD5}
N8	FLASH.CS3	O/Z	NA	NA		4 mA	A, H2	1	DV _{DD5}
M4	FLASH.CS2	O/Z	regD[8:6] = 000	NA		4 mA	A, H2	1	DV _{DD5}
	FLASH.BAA	O/Z	regD[8:6] = 001	NA					
M3	FLASH.CS1	O/Z	NA	NA		4 mA	A, H2	1	DV _{DD5}
M7	FLASH.CS0	O/Z	NA	NA		4 mA	A, H2	1	DV _{DD5}
M8 L3	FLASH.BE[1:0]	O/Z	NA	NA		4 mA	A, H2	0	DV _{DD5}
L4	FLASH.ADV	O/Z	NA	NA		4 mA	A, H2	1	DV _{DD5}

† I = Input, O = Output, Z = High-Impedance

‡ 'regx' denotes the terminal multiplexing register that controls the specified terminal where regx = FUNC_MUX_CTRL_x

§ PD20 = 20- μ A internal pulldown, PD100 = 100- μ A pulldown, PU20 = 20- μ A internal pullup, PU100 = 100- μ A internal pullup

¶ A = Standard LVCMOS input/output

G1 = Terminal may be gated by BFAIL

B = Fail-safe LVCMOS input/output

G2 = Terminal may be gated by GPIO9 and MPUIO3

C = USB transceiver input/output

G3 = Terminal may be gated by BFAIL and PWRON_RESET

D = I²C input/output buffers

H1 = Terminal may be 3-stated by BFAIL input

E = Fail-safe LVCMOS input and Standard LVCMOS output

H2 = Terminal may be 3-stated via software configuration

F = analog oscillator terminals

J = Boundary-scannable terminal

Z = High-Impedance, LZ = Low-Impedance (pin is driven), 1 = Output driven high, 0 = Output driven low

|| UART1 signals can be multiplexed to this pin via additional multiplexing in the USB module.

Table 2–2. Terminal Characteristics and Multiplexing (Continued)

BALL	SIGNAL NAME	TYPE†	MUX CTRL SETTING‡	DESELECTED INPUT STATE	PULLUP/PULLDN§	BUFFER STRENGTH	OTHER¶	RESET STATE#	SUPPLY
L7 K3 K4 L8 J1 J3 J4 J2 K7 H3 H4 K8 G2 G3 G4 F3 J7 E3 F4 D2 E4 C1 D3 J8	FLASH.A[24:1]	O/Z	NA	NA		4 mA	A, G1, H2	0	DV _{DD5}
H7	FLASH.RDY	I	NA	NA			B	input	DV _{DD5}
E5	RSVD	NA	NA	NA				NA	NA

† I = Input, O = Output, Z = High-Impedance

‡ 'regx' denotes the terminal multiplexing register that controls the specified terminal where regx = FUNC_MUX_CTRL_x

§ PD20 = 20- μ A internal pulldown, PD100 = 100- μ A pulldown, PU20 = 20- μ A internal pullup, PU100 = 100- μ A internal pullup

¶ A = Standard LVCMOS input/output

B = Fail-safe LVCMOS input/output

C = USB transceiver input/output

D = I²C input/output buffers

E = Fail-safe LVCMOS input and Standard LVCMOS output

F = analog oscillator terminals

G1 = Terminal may be gated by BFAIL

G2 = Terminal may be gated by GPIO9 and MPUIO3

G3 = Terminal may be gated by BFAIL and PWRON_RESET

H1 = Terminal may be 3-stated by BFAIL input

H2 = Terminal may be 3-stated via software configuration

J = Boundary-scannable terminal

Z = High-Impedance, LZ = Low-Impedance (pin is driven), 1 = Output driven high, 0 = Output driven low

|| UART1 signals can be multiplexed to this pin via additional multiplexing in the USB module.

2.4 Signal Description

Table 2–3 provides a description of the signals on OMAP5910. Many signals are available on multiple pins depending upon the software configuration of the pin multiplexing options. Ball numbers which are italicized indicate the default pin muxings at reset. Ball numbers for busses are listed from MSB to LSB (left to right, top to bottom).

Table 2–3. Signal Description

SIGNAL	BALL	DESCRIPTION	TYPE†
EMIFF SDRAM Interface			
SDRAM.WE	C3	SDRAM write enable. SDRAM.WE is active (low) during writes, DCAB, and MRS commands to SDRAM memory.	O/Z
SDRAM.RAS	A2	SDRAM row address strobe. SDRAM.RAS is active (low) during ACTV, DCAB, REFR, and MRS commands to SDRAM memory.	O/Z
SDRAM.DQMU	D4	SDRAM upper data mask. Active-low data mask for the upper byte of the SDRAM data bus (SDRAM.D[15:8]). The data mask outputs allow for both 16-bit-wide and 8-bit-wide accesses to SDRAM memories.	O/Z
SDRAM.DQML	B3	SDRAM lower data mask. Active-low data mask for the lower byte of the SDRAM data bus (SDRAM.D[7:0]). The data mask outputs allow for both 16-bit-wide and 8-bit-wide accesses to SDRAM memories.	O/Z
SDRAM.D[15:0]	<i>D5, C4, B4, D6, C5, H8, C6, B6, D7, C7, D8, B8, G8, C8, G9, B9</i>	SDRAM data bus. SDRAM.D[15:0] provides data exchange between the Traffic Controller and SDRAM memory.	I/O/Z
SDRAM.CKE	D9	SDRAM clock enable. Active-high output which enables the SDRAM clock during normal operation; SDRAM.CKE is driven inactive to put the memory into low-power mode.	O/Z
SDRAM.CLK	C9	SDRAM clock. Clock for synchronization SDRAM memory commands/accesses. To minimize voltage undershoot and overshoot effects, it is recommended to place a series resistor (typically ~33 ohms) close to the SDRAM.CLK driver pin.	I/O/Z
SDRAM.CAS	H9	SDRAM column address strobe. SDRAM.CAS is active (low) during reads, writes, and the REFR and MRS commands to SDRAM memory.	O/Z
SDRAM.BA[1:0]	<i>D10, C10</i>	SDRAM bank address bus. Provides the bank address to SDRAM memories.	O/Z
SDRAM.A[12:0]	<i>G10, H10, C11, D11, G11, C12, D12, H11, C13, D13, G12, C14, B14</i>	SDRAM address bus. Provides row and column address information to the SDRAM memory as well as MRS command data. SDRAM.A[10] also serves as a control signal to define specific commands to SDRAM memory.	O/Z
EMIFS FLASH and Asynchronous Memory Interface			
FLASH.WP	V4	EMIFS write protect. Active-low output for hardware write protection feature on standard memory devices.	O/Z
FLASH.WE	W2	EMIFS write enable. Active-low write enable output for Flash or SRAM memories or asynchronous devices.	O/Z
FLASH.RP	W1	EMIFS power down (TI flash devices) or reset output (Intel flash devices)	O/Z
FLASH.OE	U4	EMIFS output enable. Active-low output enable output for Flash or SRAM memories or asynchronous devices.	O/Z

† I = Input, O = Output, Z = High-Impedance

‡ All core voltage supplies should be tied to the same voltage level (within 0.3 V). During system prototyping phases, it may be useful to maintain a capability for independent measurement of core supply currents to facilitate power optimization experiments.

Table 2–3. Signal Description (Continued)

SIGNAL	BALL	DESCRIPTION	TYPE†
EMIFS FLASH and Asynchronous Memory Interface (Continued)			
FLASH.D[15:0]	V3, T4, U3, U1, P8, T3, T2, R4, R3, R2, P7, P4, P2, N7, N2, N4	EMIFS data bus. Bidirectional 16-bit data bus used to transfer read and write data during EMIFS accesses.	I/O/Z
FLASH.CLK	N3	EMIFS clock. Clock output that is active during synchronous modes of EMIFS operation for synchronous burst Flash memories.	O/Z
FLASH.CS3	N8	EMIFS chip selects. Active-low chip-select outputs that become active when the appropriate address is decoded internal to the device. Each chip select decodes a 32M-byte region of memory space.	O/Z
FLASH.CS2	M4		
FLASH.CS1	M3		
FLASH.CS0	M7		
FLASH.BE[1:0]	M8, L3	EMIFS byte enables. Active-low byte enable signals used to perform byte-wide accesses to memories or devices that support byte enables.	O/Z
FLASH.ADV	L4	EMIFS address valid. Active-low control signal used to indicate a valid address is present on the FLASH.A[24:1] bus.	O/Z
FLASH.BAA	M4	EMIFS burst advance <u>acknowledge</u> . Active-low control <u>signal used</u> with Advanced Micro Devices™ burst Flash. FLASH.BAA is multiplexed with FLASH.CS2.	O/Z
FLASH.A[24:1]	L7, K3, K4, L8, J1, J3, J4, J2, K7, H3, H4, K8, G2, G3, G4, F3, J7, E3, F4, D2, E4, C1, D3, J8	EMIFS address bus. Address output bus for all EMIFS accesses. FLASH.A[24:1] provides the upper 24 bits of a 25-bit byte address. The byte enables must be used to implement 8-bit accesses.	O/Z
FLASH.RDY	H7	EMIFS ready. Active-high ready input used to suspend the EMIFS interface when the external memory or asynchronous device is not ready to continue the current cycle.	I
LCD Interface			
LCD.VS	D14	LCD vertical sync output. LCD.VS is the frame clock which signals the start of a new frame of pixels to the LCD display panel. In TFT mode, LCD.VS is the vertical synchronization signal.	O
LCD.HS	H12	LCD horizontal sync. LCD.HS is the line clock which signals the end of a line of pixels to the LCD display panel. In TFT mode, LCD.HS is the horizontal synchronization signal.	O
LCD.AC	B15	LCD AC-bias. LCD.AC is used to signal the LCD display to switch the polarity of the row and column power supplies to counteract charge buildup causing DC offset. In TFT mode, LCD.AC is used as the output enable to latch LCD pixel data using the pixel clock.	O
LCD.PCLK	C15	LCD pixel clock output. Clock output provided to synchronize pixel data to LCD display panels. In passive mode, LCD.PCLK only transitions when LCD.P[15:0] is valid. In active mode, LCD.PCLK transitions continuously and LCD.AC is used as the output enable when LCD.P[15:0] is valid.	O

† I = Input, O = Output, Z = High-Impedance

‡ All core voltage supplies should be tied to the same voltage level (within 0.3 V). During system prototyping phases, it may be useful to maintain a capability for independent measurement of core supply currents to facilitate power optimization experiments.

Advanced Micro Devices is a trademark of Advanced Micro Devices, Inc.

Table 2–3. Signal Description (Continued)

SIGNAL	BALL	DESCRIPTION	TYPE†
LCD Interface (Continued)			
LCD.P[15:0]	D15, C16, A17, G13, B17, C17, D16, D17, C18, B19, A20, H13, G14, C19, B21, D18	LCD pixel data bus. Pixel data is transferred on this output bus to LCD panels.	O
Keyboard Matrix Interface			
KB.C[7:0]	V19, P15, C20, C21, E18, D19, D20, F18	Keyboard matrix column outputs. KB.Cx column outputs are used in conjunction with the KB.Rx row inputs to implement a 6x5 or 8x8 keyboard matrix.	O
KB.R[7:0]	M20, N21, N19, E19, E20, H14, F19, G18	Keyboard matrix row inputs. KB.Rx row inputs are used in conjunction with the KB.Cx column outputs to implement a 6x5 or 8x8 keyboard matrix.	I
Multichannel Buffered Serial Ports (McBSPs)			
MCBSP1.CLKS	G20	McBSP1 clock source. Provides external clock reference for use with transmitter or receiver. CLKS is only present on McBSP1.	I
MCBSP1.CLKX	G21	McBSP transmit clock. Serial shift clock reference for the transmitter. CLKX is present on all McBSPs. In the case of McBSP1 and McBSP3, the clock input to the McBSP receiver may also be provided on this terminal via an internal loop-back connection between the transmitter and receiver clocks.	I/O/Z
MCBSP2.CLKX	Y6		
MCBSP3.CLKX	W16, N14		
MCBSP1.FSX	H15, H18	McBSP transmit frame sync. Frame synchronization for transmitter. FSX is present on all McBSPs. In the case of McBSP1 and McBSP3, the frame sync input to the McBSP receiver may also be provided on this terminal via an internal loop-back connection between the transmitter and receiver frame syncs.	I/O/Z
MCBSP2.FSX	W7		
MCBSP3.FSX	N18, P18, P19, P20		
MCBSP1.DX	H18, H15	McBSP transmit data. Serial transmit data output. DX is present on all McBSPs.	O
MCBSP2.DX	AA5, P10		
MCBSP3.DX	P14, W21		
MCBSP2.CLKR	V7	McBSP2 receive clock. Serial shift clock reference for the receiver. CLKR is only present on McBSP2.	I/O/Z
MCBSP2.FSR	W6	McBSP2 receive frame sync. Frame synchronization for the receiver. FSR is only present on McBSP2.	I/O/Z
MCBSP1.DR	H20	McBSP receive data. Serial receive data input. DR is present on all McBSPs.	I
MCBSP2.DR	P10, AA5		
MCBSP3.DR	AA17, U18		
Camera Interface			
CAM.EXCLK	H19	Camera interface external clock. Output clock used to provide a timing reference to a camera sensor.	O
CAM.LCLK	J15	Camera interface line clock. Input clock to provide external timing reference from camera sensor logic.	I
CAM.VS	L18	Camera interface vertical sync. Vertical synchronization input from external camera sensor.	I
CAM.HS	L15	Camera interface horizontal sync. Horizontal synchronization input from external camera sensor.	I

† I = Input, O = Output, Z = High-Impedance

‡ All core voltage supplies should be tied to the same voltage level (within 0.3 V). During system prototyping phases, it may be useful to maintain a capability for independent measurement of core supply currents to facilitate power optimization experiments.

Table 2–3. Signal Description (Continued)

SIGNAL	BALL	DESCRIPTION	TYPE†
Camera Interface (Continued)			
CAM.D[7:0]	J18, J19, J14, K18, K19, K15, K14, L19	Camera interface data. Data input bus to receive image data from an external camera sensor.	I
CAM.RSTZ	M19	Camera interface reset. Reset output used to reset or Initialize external camera sensor logic.	O
ETM9 Trace Macro Interface			
ETM.CLK	J15	ETM9 Trace Clock. Clock output for standard ETM9 test/debug equipment.	O
ETM.SYNC	H19	ETM9 Trace Synchronization. Trace Sync output for standard ETM9 test/debug equipment.	O
ETM.D[7:0]	J18, J19, J14, K18, K19, K15, K14, L19	ETM9 Trace Packet data. Trace Packet outputs for standard ETM9 test/debug equipment.	O
ETM.PSTAT[2:0]	L18, L15, M19	ETM9 Trace Pipe State 2–0. Pipeline status outputs for standard ETM9 test/debug equipment.	O
Microwire Interface			
UWIRE.SCLK	V19, J15	Microwire serial clock. This pin drives a clock to a Microwire device. The active edge is software configurable.	O
UWIRE.SDO	W21, H19	Microwire serial data out. Write data is transferred to a Microwire device on this pin.	O
UWIRE.SDI	U18, J14	Microwire serial data in. Read data is transferred from a Microwire device on this pin.	I
UWIRE.CS0	N14, J18	Microwire chip select 0. The CS0 output selects a single Microwire device (configurable as active high or active low).	O
UWIRE.CS3	P15, J19	Microwire chip select 3. The CS3 output selects a single Microwire device (configurable as active high or active low).	O
HDQ/1-Wire Interface			
HDQ	N20	HDQ/1-wire interface. HDQ optionally implements one of two serial protocols: HDQ or 1-Wire.	I/O
General-Purpose I/O (GPIO) and MPU I/O (MPUIO)			
GPIO15	M20	Shared General-Purpose I/O. Each GPIO pin can be used by either the DSP core or the MPU core. Control of each GPIO pin between the two cores is selected by the MPU via control registers. Each GPIO pin may also be configured to cause an interrupt to its respective core processor. GPIO5 and GPIO10 are not available on the OMAP5910 device.	I/O/Z
GPIO14	N21		
GPIO13	N19		
GPIO12	N18, W6		
GPIO11	N20, V7		
GPIO9	W8		
GPIO8	Y8		
GPIO7	M15, Y5, V9		
GPIO6	P19		
GPIO4	P20		
GPIO3	P18		
GPIO2	M14		
GPIO1	R19		
GPIO0	R18		

† I = Input, O = Output, Z = High-Impedance

‡ All core voltage supplies should be tied to the same voltage level (within 0.3 V). During system prototyping phases, it may be useful to maintain a capability for independent measurement of core supply currents to facilitate power optimization experiments.

Table 2–3. Signal Description (Continued)

SIGNAL	BALL	DESCRIPTION	TYPE†
General-Purpose I/O (GPIO) and MPU I/O (MPUIO) (Continued)			
MPUIO12	L19	MPUIO8, MPUIO9, AND MPUIO10 are not available on the OMAP5910 device.	I/O/Z
MPUIO11	W10		
MPUIO7	V10		
MPUIO6	W11		
MPUIO5	T20, W5		
MPUIO4	T19		
MPUIO3	V8		
MPUIO2	N15		
MPUIO1	U19		
MPUIO0	Y12		
Pulse-Width Tone and Pulse-Width Light Interface			
PWT	M18	Pulse Width Tone output. The PWT output pin provides a modulated output for use with an external buzzer.	O
PWL	L14	Pulse Width Light output. The PWL output pin provides a pseudo-random modulated voltage output used for LCD or keypad backlighting.	O
Multimedia Card/Secure Digital Interface (MMC/SD)			
MMC.CLK	V11	MMC/SD clock. Clock output to the MMC/SD card.	O
MMC.CMD/SPI.DO	P11	MMC/SD command / SPI data output. MMC/SD commands are transferred to/from this pin. The pin functions as the data output during SPI mode.	I/O/Z
MMC.DAT3	W11	SD card data bit 3. Data bit 3 used in 4-bit Secure Digital mode.	I/O/Z
MMC.DAT2	W10, M15	SD card data bit 2. Data bit 2 used in 4-bit Secure Digital mode.	I/O/Z
MMC.DAT1	V10	SD card data bit 1. Data bit 1 used in 4-bit Secure Digital mode.	I/O/Z
MMC.DAT0/SPI.DI	R11	MMC/SD dat0 / SPI input. MMC.DAT0/SPI.DI functions as data bit 0 during MMC and Secure Digital operation. The pin functions as the data input in generic SPI mode.	I/O/Z
SPI.CLK	M14	SPI clock. SPI clock output used during generic SPI mode operation.	O
SPI.CS3	P18	SPI chip selects. SPI chip selects used during generic SPI mode operation.	O
SPI.CS2	P20		
SPI.CS1	P19		
SPI.RDY	R18	SPI ready. SPI ready input from SPI device used only in generic SPI mode operation.	I
Universal Asynchronous Receiver/Transmitter Interfaces			
UART1.TX	Y14	UART transmit. Transmit data output. TX is present on all UARTs. On UART3, the TX pin implements the TXIR function during SIR mode operation.	O
UART2.TX	V6, M18		
UART3.TX	M18, K18		
UART1.RX	V14	UART receive. Receive data input. RX is present on all UARTs. On UART3, the RX pin implements the RXIR function during SIR mode operation.	I
UART2.RX	R9, L14		
UART3.RX	L14, K19		
UART1.CTS	R14	UART clear-to-send. CTS is present on all UARTs.	I
UART2.CTS	Y5, L15		
UART3.CTS	R13, K15		
UART1.RTS	AA15	UART request-to-send. RTS is present on all UARTs. On UART3 in IrDA mode, this pin is SD_MODE.	O
UART2.RTS	W5, M19		
UART3.RTS	Y13, R19		

† I = Input, O = Output, Z = High-Impedance

‡ All core voltage supplies should be tied to the same voltage level (within 0.3 V). During system prototyping phases, it may be useful to maintain a capability for independent measurement of core supply currents to facilitate power optimization experiments.

Table 2–3. Signal Description (Continued)

SIGNAL	BALL	DESCRIPTION	TYPE†
Universal Asynchronous Receiver/Transmitter Interfaces (Continued)			
UART1.DTR	W21, Y13	UART data-terminal-ready. DTR is only present on UART1 and UART3.	O
UART3.DTR	W21		
UART1.DSR	U18, R13	UART data-set-ready. DSR is only present on UART1 and UART3.	I
UART3.DSR	U18		
UART2.BCLK	Y4	UART baud clock output. A clock of 16x of the UART2 baud rate is driven onto this pin. This feature is only implemented on UART2.	O
Inter-Integrated Circuit Master and Slave Interface			
I2C.SCL	T18	I ² C serial clock. I2C.SCL provides the timing reference for I ² C transfers.	I/O/Z
I2C.SDA	V20	I ² C serial data. I2C.SDA provides control and data for I ² C transfers.	I/O/Z
LED Pulse Generator Interface			
LED1	P18	LED Pulse Generator output 1. LED1 produces a static or pulsing output used to drive an external LED indicator.	O
LED2	T19	LED Pulse Generator output 2. LED2 produces a static or pulsing output used to drive an external LED indicator.	O
Multichannel Serial Interfaces (MCSIs)			
MCSI1.CLK	AA13	MCSI clock. Multichannel Serial Interface clock reference. The clock can be driven in master mode or an external clock may be driven on this signal in slave mode.	I/O/Z
MCSI2.CLK	Y10		
MCSI1.SYNC	V13	MCSI sync. Multichannel Serial Interface frame synchronization signal. The frame sync can be driven in master mode or an external clock may be driven on this signal in slave mode. MCSIx.SYNC may be configured as an active-low or active-high sync.	I/O/Z
MCSI2.SYNC	V9		
MCSI1.DIN	W13	MCSI data in. Multichannel Serial Interface data input pin.	I
MCSI2.DIN	AA9		
MCSI1.DOUT	W14	MCSI data out. Multichannel Serial Interface data output pin.	O
MCSI2.DOUT	W9		
USB (Integrated Transceiver Interface, can be used with Host or Function)			
USB.DP	P9	USB internal transceiver D+. The positive side of the integrated USB transceiver's differential bus.	I/O/Z
USB.DM	R8	USB internal transceiver D-. The negative side of the integrated USB transceiver's differential bus.	I/O/Z
USB Pin Group 1 and 2 (Utilizing External Transceivers, can be used with Host or Function)			
USB1.TXEN	W16	USB transmit enable. Driven active (high) when the USB host or Function peripheral is driving data onto the USB bus via the TXD output.	O
USB2.TXEN	W9		
USB1.TXD	W14	USB transmit data. Single-ended logic output used to transmit data to the transmit input of an external USB transceiver. USBx.TXD may also be used for transceiverless connection between OMAP5910 and another transceiverless USB device.	O
USB2.TXD	V6		
USB1.VP	V13	USB vplus data. Single-ended input used to monitor the logical state of the D+ line of the USB bus. USBx.VP should be driven by an external USB transceiver based on the state of D+.	I
USB2.VP	AA9		
USB1.VM	AA13	USB vplus data. Single-ended input used to monitor the logical state of the D- line of the USB bus. USBx.VM should be driven by an external USB transceiver based on the state of D-.	I
USB2.VM	R9		
USB1.RCV	W13	USB receive data. Single-ended logic input used to receive data from the receive output of an external USB transceiver. USBx.RCV may also be used for transceiverless connection between OMAP5910 and another transceiverless USB device.	I
USB2.RCV	Y5		

† I = Input, O = Output, Z = High-Impedance

‡ All core voltage supplies should be tied to the same voltage level (within 0.3 V). During system prototyping phases, it may be useful to maintain a capability for independent measurement of core supply currents to facilitate power optimization experiments.

Table 2–3. Signal Description (Continued)

SIGNAL	BALL	DESCRIPTION	TYPE†
USB Pin Group 1 and 2 (Utilizing External Transceivers, can be used with Host or Function) (Continued)			
USB1.SUSP	AA17	USB bus segment suspend control. Active-high output indicates detection of IDLE condition on the USB bus for greater than 5 ms. USBx.SUSP is implemented on both USB ports 1 and 2.	O
USB2.SUSP	Y10		
USB1.SE0	P14	USB single-ended zero. Active-high output indicates detection of the single-ended zero state on the USB bus. USBx.SE0 is implemented for both USB ports 1 and 2.	O
USB2.SE0	W5		
USB1.SPEED	Y12	USB 1 bus segment speed control. Static control output used by the external transceiver to determine whether USB port 1 is operating in full-speed or low-speed mode. USB1.SPEED is only implemented on USB port 1.	O
USB Miscellaneous Signals			
USB.CLKO	W4	USB clock output. 6-MHz divided clock output of the internal USB DPLL provided for reference. Common for all USB host and Function peripherals.	O
USB.PUEN	W4	USB pullup enable. Control output used in conjunction with an external pullup resistor to implement USB device connect and disconnect via software. USB.PUEN is used with the USB Function peripheral.	O
USB.VBUS	R18	USB voltage bus enable. USB.VBUS is used to provide a logic-high voltage level which may be used to enable pullup resistors on the USB bus to indicate connection or disconnection status of the OMAP5910 device as a USB Function device.	O
JTAG/Emulation Interface			
TCK	W18	IEEE Standard 1149.1 test clock. TCK is normally a free-running clock signal with a 50% duty cycle. The changes on the test access port (TAP) of input signals TDI and TMS are clocked into the TAP controller, instruction register, or selected test data register on the rising edge of TCK. Changes at the TAP output signal TDO occur on the falling edge of TCK.	I
TDI	Y19	IEEE Standard 1149.1 test data input. TDI is clocked into the selected register (instruction or data) on the rising edge of TCK.	I
TDO	AA19	IEEE Standard 1149.1 test data output. The contents of the selected register (instruction or data) are shifted out of TDO on the falling edge of TCK. TDO is in the high-impedance state except when the scanning of data is in progress.	O
TMS	V17	IEEE Standard 1149.1 test mode select. This serial control input is clocked into the TAP controller on the rising edge of TCK.	I
$\overline{\text{TRST}}$	Y18	IEEE Standard 1149.1 test reset. $\overline{\text{TRST}}$, when high, gives the IEEE standard 1149.1 scan system control of the operations of the device. If $\overline{\text{TRST}}$ is not connected, or driven low, the device operates in its functional mode, and the IEEE standard 1149.1 signals are ignored.	I
EMU0	V16	Emulation pin 0. When $\overline{\text{TRST}}$ is driven high, EMU0 is used as an interrupt to or from the emulator system and is defined as input/output by way of the IEEE standard 1149.1 scan system.	I/O
EMU1	W17	Emulation pin 1. When $\overline{\text{TRST}}$ is driven high, EMU1 is used as an interrupt to or from the emulator system and is defined as input/output by way of the IEEE standard 1149.1 scan system.	I/O
Device Clock Pins			
CLK32K_IN	P13	32-kHz clock input. Digital CMOS 32-kHz clock input driven by an external 32-kHz oscillator if the internal 32-kHz oscillator is not used.	I
CLK32K_OUT	Y12	32-kHz clock output. Clock output reflecting the internal 32-kHz clock.	O
CLK32K_CTRL	AA20	32-kHz clock selection control input. CLK32K_CTRL selects whether or not the internal 32-kHz oscillator is used or if the 32-kHz clock is to be provided externally via the CLK32K_IN input. If CLK32K_CTRL is high, the 32-kHz internal oscillator is used; if CLK32K_CTRL is low, the CMOS input CLK32K_IN is used as a 32-kHz clock source.	I

† I = Input, O = Output, Z = High-Impedance

‡ All core voltage supplies should be tied to the same voltage level (within 0.3 V). During system prototyping phases, it may be useful to maintain a capability for independent measurement of core supply currents to facilitate power optimization experiments.

Table 2–3. Signal Description (Continued)

SIGNAL	BALL	DESCRIPTION	TYPE†
Device Clock Pins (Continued)			
OSC32K_IN	W12	32-kHz crystal XI connection. Analog clock input to 32-kHz oscillator for use with external crystal.	analog
OSC32K_OUT	R12	32-kHz crystal XO connection. Analog output from 32-kHz oscillator for use with external crystal.	analog
OSC1_IN	Y2	12-MHz crystal XI connection. Analog input to 12-MHz oscillator for use with external crystal or to be driven by external 12-MHz oscillator.	analog
OSC1_OUT	W3	12-MHz crystal XO connection. Analog output from 12-MHz oscillator for use with external crystal.	analog
MCLK	Y9	M-Clock. General-purpose clock output when may be configured to run at 12 MHz or 48 MHz. MCLK may be configured to drive constantly or only when the MCLKREQ signal is asserted active high.	O
BCLK	Y13	B-Clock. General purpose clock output which may be configured to run at 12 MHz or 48 MHz. BCLK may be configured to drive constantly or only when the BCLKREQ signal is asserted active high.	O
MCLKREQ	R10	M-Clock Request. Active high request input which allows an external device to request that MCLK be driven.	I
BCLKREQ	R13	B-Clock Request. Active high request input which allows an external device to request that BCLK be driven.	I
Reset Logic Pins			
PWRON_RESET	G19	Reset input to device. Active-low asynchronous reset input resets the entire OMAP5910 device.	I
MPU_RST	V15	MPU reset input. Active-low asynchronous reset input resets the MPU core.	I
RST_OUT	W15	Reset output. Active-low output is asserted when MPUST is active (after synchronization.)	O
Interrupts and Miscellaneous Control and Configuration Pins			
MPU_BOOT	AA17	MPU boot mode. When MPU_BOOT is low, the MPU boots from chip select 0 of the EMIFS (Flash) interface. When MPU_BOOT is high, the MPU boots from chip select 3 of EMIFS.	I
DMA_REQ_OBS	L14	DMA request external observation output.	O
IRQ_OBS	M18	IRQ external observation output.	O
EXT_DMA_REQ1	T19	External DMA requests. EXT_DMA_REQ0 and EXT_DMA_REQ1 provide two DMA request inputs which external devices may use to trigger System DMA transfers. The System DMA must be configured in software to respond to these external requests.	I
EXT_DMA_REQ0	N15		
BFAIL/EXT_FIQ	W19	Battery power failure and external FIQ interrupt input. BFAIL/EXT_FIQ may be used to gate certain input pins when battery power is low or failing. The pins which may be gated are configured via software. This pin can also optionally be used as an external FIQ interrupt source to the MPU. The function of this pin is configurable via software.	I
EXT_MASTER_REQ	R10	External master request. If the 12-MHz clock is provided by an external device instead of using the on-chip oscillator, a high level on this output indicates to the external device that the clock must be driven. A low level indicates that the OMAP5910 device is in sleep mode and the 12-MHz clock is not necessary.	O
LOW_PWR	T20	Low-power request output. This active-high output indicates that the OMAP5910 device is in a low-power sleep mode. During reset and functional modes, LOW_PWR is driven low. This signal can be used to indicate a low-power state to external power management devices in a system or it can be used as a chip select to external SDRAM memory to minimize current consumption while the SDRAM is in self-refresh and the OMAP5910 device is in sleep mode.	O
CONF	V18	Configuration input. CONF selects reserved factory test modes. CONF should always be pulled low during device operation.	O

† I = Input, O = Output, Z = High-Impedance

‡ All core voltage supplies should be tied to the same voltage level (within 0.3 V). During system prototyping phases, it may be useful to maintain a capability for independent measurement of core supply currents to facilitate power optimization experiments.

Table 2–3. Signal Description (Continued)

SIGNAL	BALL	DESCRIPTION	TYPE†
Interrupts and Miscellaneous Control and Configuration Pins (Continued)			
STAT_VAL/ $\overline{\text{WKUP}}$	Y17	Static Valid / Chip wake-up input. STAT_VAL/ $\overline{\text{WKUP}}$ may be configured via software to function as an external wake-up signal to the OMAP5910 device to request chip wake-up during sleep modes. STAT_VAL/ $\overline{\text{WKUP}}$ is also sampled at reset to select the MMC/SD port. If the MMC/SD peripheral is to be used, this pin must be pulled high during reset. It is recommended that this pin be pulled high during reset regardless of whether or not MMC/SD will be used.	I
RST_HOST_OUT	P14	Reset Host output. A software controllable Reset or Shutdown output to an external device.	O
RSVD	E5	Reserved pin. This pin must be left unconnected.	–
Power Supplies			
VSS	A21, B1, B2, B5, B7, B16, B18, E2, F20, G1, J20, K2, K20, N1, R21, U2, U20, V5, V12, W20, Y3, Y15, AA1, AA7, AA21	Ground. Common ground return for all core and I/O voltage supplies.	power
CVDD‡	A9, F2, P12, Y20	Core supply voltage. Supplies power to OMAP5910 core logic and low-voltage sections of I/O.	power
CVDD1‡	A3	Core Supply Voltage 1. Supplies power to the on-chip shared SRAM memory (192k-Bytes).	power
CVDD2‡	Y1, AA3	Core Supply Voltage 2. Supplies power to the MPU subsystem logic and memory.	power
CVDD3‡	B13, B20, J21, R20	Core Supply Voltage 3. Supplies power to the DSP subsystem logic and memory.	power
CVDD4‡	M2	Core Supply Voltage 4. Supplies power to the DPLL which provides internal clocks to the core and peripherals (excluding USB peripherals). NOTE: The voltage to this supply pin should be kept as clean as possible to maximize performance.	power
CVDDA‡	Y21	Analog supply voltage. Supplies power to ULPD DPLL which provides an internal clock to the USB peripherals. NOTE: The voltage to this supply pin should be kept as clean as possible to maximize performance.	power
DVDD1	A15, A19, E21, L21, U21, AA11	I/O Supply Voltage 1. Supplies power to the majority of peripheral I/O buffers. DVDD1 may be connected in common with the other DVDD supplies if the same operating voltage is desired.	power
DVDD2	AA2	I/O Supply Voltage 2. Supplies power to the internal USB transceiver buffers. DVDD2 may optionally be used for USB connect & disconnect detection by connecting DVDD2 to the power from the USB bus in the system. DVDD2 may be connected in common with the other DVDD supplies if the same operating voltage is desired.	power
DVDD3	Y7, Y16	I/O Supply Voltage 3. Supplies power to the MCS12 and McBSP2 peripheral I/O buffers as well as GPIO[9:8] I/O buffers. The DVDD3 supply may operate within a high-voltage or low-voltage range (see Section 5.2 for operating conditions). DVDD3 may be connected in common with the other DVDD supplies if the same operating voltage is desired.	power

† I = Input, O = Output, Z = High-Impedance

‡ All core voltage supplies should be tied to the same voltage level (within 0.3 V). During system prototyping phases, it may be useful to maintain a capability for independent measurement of core supply currents to facilitate power optimization experiments.

Table 2–3. Signal Description (Continued)

SIGNAL	BALL	DESCRIPTION	TYPE†
Power Supplies (Continued)			
DV _{DD4}	A1, A5, A7, B10, B12	I/O Supply Voltage 4. Supplies power to the SDRAM interface I/O buffers. The DV _{DD4} supply may operate within a high-voltage or low-voltage range (see Section 5.2 for operating conditions). DV _{DD4} may be connected in common with the other DV _{DD} supplies if the same operating voltage is desired.	power
DV _{DD5}	C2, E1, H2, L1, P3, R1, V2	I/O Supply Voltage 5. Supplies power to the FLASH interface I/O buffers. The DV _{DD5} supply may operate within a high-voltage or low-voltage range (see Section 5.2 for operating conditions). DV _{DD5} may be connected in common with the other DV _{DD} supplies if the same operating voltage is desired.	power

† I = Input, O = Output, Z = High-Impedance

‡ All core voltage supplies should be tied to the same voltage level (within 0.3 V). During system prototyping phases, it may be useful to maintain a capability for independent measurement of core supply currents to facilitate power optimization experiments.

PRODUCT PREVIEW

3 Functional Overview

The following functional overview is based on the block diagram in Figure 3-1.

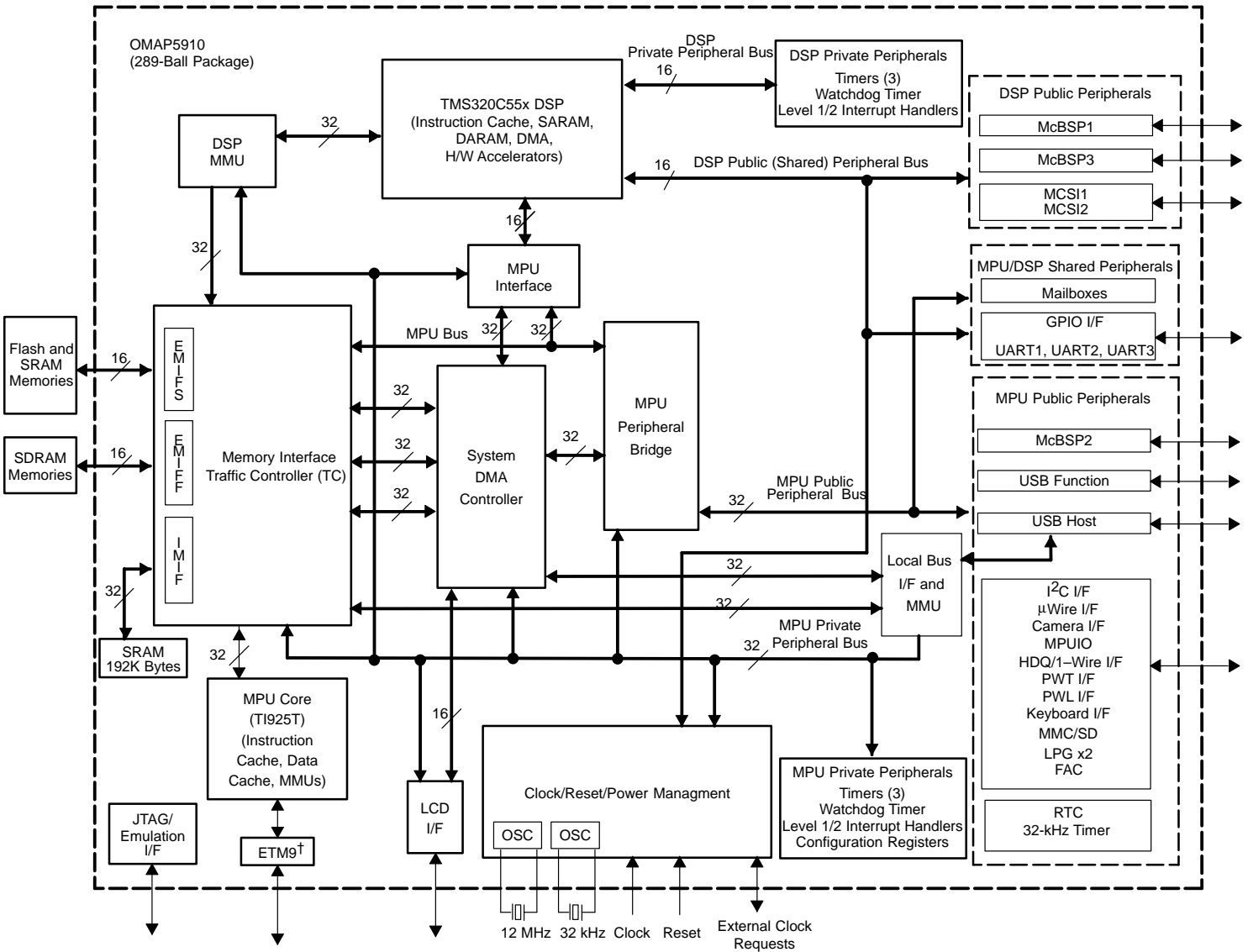

† ETM9 pins are shared with the Camera Interface.

Figure 3-1. OMAP5910 Functional Block Diagram

3.1 Functional Block Diagram Features

The OMAP5910 device includes the following functional blocks:

- ARM9TDMI-based MPU core
 - 16K-byte instruction cache and 8K-byte data cache
 - Memory Management Units (MMUs) for Instruction and Data
 - Two 64-entry Translation Look-Aside Buffers (TLBs) for MMUs
 - 17-word write buffer
- C55x DSP subsystem
 - 48K-word single-access RAM (SARAM) (96K bytes)
 - 32K-word dual-access RAM (DARAM) (64K bytes)
 - 16K-word ROM (32K bytes)
 - 24K-byte instruction cache
 - Six-channel DMA controller
 - Hardware Accelerators for DCT, iDCT, pixel interpolation, and motion estimation
- Nine-channel system DMA controller
- Traffic controller providing shared access to three memory interfaces:
 - EMIFF External Memory Interface providing 16-bit interface to 64M bytes of standard SDRAM
 - EMIFS External Memory Interface providing 16-bit interface to 128M bytes of Flash, ROM, or asynchronous memories
 - Internal Memory Interface providing 32-bit interface to 192K bytes of internal SRAM
- DSP Memory Management Unit (MMU) configured by the MPU
- MPU Interface allowing MPU and System DMA to access DSP subsystem memory and DSP public peripherals
- Local Bus Interface (with MMU) allowing USB host peripheral direct access to system memories.
- DSP Private Peripherals (accessible only by the DSP)
 - Three 32-bit general-purpose timers
 - Watchdog timer
 - Level 1/Level 2 interrupt handlers
- DSP Public Peripherals (accessible by the DSP, DSP DMA, and the MPU via the MPU interface)
 - Two Multichannel Buffered Serial Ports (McBSPs)
 - Two Multichannel Serial Interfaces (MCSIs) ideal for voice data
- MPU Private Peripherals (accessible only by the MPU)
 - Three 32-bit general-purpose timers
 - Watchdog Timer
 - Level 1/Level 2 interrupt handlers
 - Configuration Registers for pin-multiplexing and other device-level configurations
 - LCD controller supporting monochrome panels or STN and TFT color panels

- MPU Public Peripherals (accessible by the MPU and the System DMA)
 - Multichannel Buffered Serial Port (McBSP)
 - USB 1.1 Function interface (optional internal transceiver shared with USB Host interface)
 - USB 1.1 Host interface with up to three ports (optional internal transceiver shared with USB Function interface)
 - One integrated USB transceiver for either host or Function
 - Inter-Integrated Circuit (I²C) Multi-mode master and slave interface
 - Microwire serial interface
 - Camera interface providing connectivity to CMOS image sensors
 - Up to ten MPU general-purpose I/Os (MPUIOs)
 - 32-kHz timer for use with MPU OS
 - Pulse-Width Tone (PWT) module for tone generation
 - Pulse-Width Light (PWL) module for LCD backlight control
 - Keyboard interface (6 x 5 or 8 x 8 matrix)
 - Multimedia Card or Secure Digital interface (MMC/SD) – also configurable as generic SPI port
 - Two LED Pulse Generator modules (LPG)
 - Real-Time Clock module (RTC)
 - HDQ or 1-Wire Master interface for serial communication to battery management devices
 - Frame Adjustment Counter (FAC)
- MPU/DSP Shared Peripherals (Controlling processor is selected by the MPU)
 - Four Mailboxes for interprocessor communications
 - Up to 14 General-Purpose I/O pins with interrupt capability to either processor
 - Three UARTs (UART3 has SIR mode for IrDA functionality)
- Clock/Reset/Power Management modules
 - Configurable Digital Phase-Locked Loop (DPLL) providing clocks to MPU, DSP, and TC
 - Dedicated USB DPLL providing clocking to USB modules
 - Integrated 12-MHz and 32-kHz oscillators utilizing external crystals
 - Reset, clocking and idle/sleep controls for power management
- JTAG and ETM9 interfaces for emulation and debug

3.2 MPU Memory Maps

3.2.1 MPU Global Memory Map

The MPU has a unified address space. Therefore, the internal and external memories for program and data as well as peripheral registers and configuration registers are all accessed within the same address space. The MPU space is always addressed using byte addressing. Table 3–1 provides a high level illustration of the entire MPU addressable space. Further detail regarding the peripheral and configuration registers is provided in Sections 3.2.2, 3.15, and 3.17.

Table 3–1. OMAP5910 MPU Global Memory Map

BYTE ADDRESS RANGE	ON-CHIP	EXTERNAL INTERFACE
0x0000 0000 – 0x01FF FFFF		Flash (CS0) 32M bytes
0x0200 0000 – 0x03FF FFFF	Reserved	
0x0400 0000 – 0x05FF FFFF		Flash (CS1) 32M bytes
0x0600 0000 – 0x07FF FFFF	Reserved	
0x0800 0000 – 0x09FF FFFF		Flash (CS2) 32M bytes
0x0A00 0000 – 0x0BFF FFFF	Reserved	
0x0C00 0000 – 0x0DFF FFFF		Flash (CS3) 32M bytes
0x0E00 0000 – 0x0FFF FFFF	Reserved	
0x1000 0000 – 0x13FF FFFF		SDRAM 64M bytes
0x1400 0000 – 0x1FFF FFFF	Reserved	
0x2000 0000 – 0x2002 FFFF	Internal SRAM 192K bytes	
0x2003 0000 – 0x2FFF FFFF	Reserved	
0x3000 0000 – 0x5FFF FFFF	Local Bus space for USB Host	
0x6000 0000 – 0xDFFF FFFF	Reserved	
0xE000 0000 – 0xE0FF FFFF	DSP public memory space (accessible via MPUI) 16M bytes	
0xE100 0000 – 0xEFFF FFFF	DSP public peripherals (accessible via MPUI)	
0xF000 0000 – 0xFFFA FFFF	Reserved	
0xFFFFB 0000 – 0xFFFFB FFFF	MPU public peripherals†	
0xFFFFC 0000 – 0xFFFFC FFFF	MPU/DSP shared peripherals	
0xFFFFD 0000 – 0xFFFFE FFFF	MPU private peripherals	
0xFFFFF 0000 – 0xFFFFF FFFF	Reserved	

† Some peripherals within this memory region are actually shared peripherals (UART 1,2,3).

3.2.2 MPU Subsystem Registers Memory Map

The MPU accesses peripheral and configuration registers in the same way that internal and external memory is accessed. The following tables specify the MPU base addresses where each set of registers is accessed. All accesses to these registers must utilize the appropriate access width (8, 16 or 32 bit wide accesses) as indicated in the tables. Accessing registers with the incorrect access width may result in unexpected results including a TI Peripheral Bus (TIPB) bus error and associated TIPB interrupt.

Refer to Sections 3.15, 3.16, and 3.17 for more detail about each of these register sets including individual register addresses, register names, descriptions, supported access types (read, write or read/write) and reset values.

Table 3–2. MPU Private Peripheral Registers

MPU BASE ADDRESS	REGISTER SET	ACCESS WIDTH
0xFFFE 0000	MPU Level 2 Interrupt Handler Registers	32
0xFFFE C000	LCD Controller Registers	32
0xFFFE C500	MPU Timer1 Registers	32
0xFFFE C600	MPU Timer2 Registers	32
0xFFFE C700	MPU Timer3 Registers	32
0xFFFE C800	MPU Watchdog Timer Registers	32
0xFFFE CB00	MPU Level 1 Interrupt Handler Registers	32
0xFFFE D800	System DMA Controller Registers	16

Table 3–3. MPU Public Peripheral Registers

MPU BASE ADDRESS	REGISTER SET	ACCESS WIDTH
0xFFFB 1000	McBSP2 Registers	16
0xFFFB 3000	Microwire Registers	16
0xFFFB 3800	I ² C Registers	16
0xFFFB 4000	USB Function Registers	16
0xFFFB 4800	RTC Registers	8
0xFFFB 5000	MPUIO/Keyboard Registers	16
0xFFFB 5800	Pulse Width Light (PWL) Registers	8
0xFFFB 6000	Pulse Width Tone (PWT) Registers	8
0xFFFB 6800	Camera Interface Registers	32
0xFFFB 7800	MMC/SD Registers	16
0xFFFB 9000	Timer 32k Registers	32
0xFFFB A000	USB Host Registers	32
0xFFFB A800	Frame Adjustment Counter (FAC) Registers	16
0xFFFB C000	HDQ/1-Wire Registers	8
0xFFFB D000	LED Pulse Generator 1 (LPG1) Registers	8
0xFFFB D800	LED Pulse Generator 2 (LPG2) Registers	8

Table 3–4. MPU/DSP Shared Peripheral Registers

MPU BASE ADDRESS	REGISTER SET	ACCESS WIDTH
0xFFFB 0000	UART1 Registers	8
0xFFFB 0800	UART2 Registers	8
0xFFFB 9800	UART3 Registers	8
0xFFFC E000	GPIO Interface Registers	16
0xFFFC F000	Mailbox Registers	16

Table 3–5. DSP Public Peripheral Registers (Accessible via MPUI Port)

MPU BASE ADDRESS	REGISTER SET	ACCESS WIDTH
0xE101 1800	McBSP1 Registers	16
0xE101 2000	MCSI2 Registers	16
0xE101 2800	MCSI1 Registers	16
0xE101 7000	McBSP3 Registers	16

Table 3–6. MPU Configuration Registers

MPU BASE ADDRESS	REGISTER SET	ACCESS WIDTH
0xFFFB C800	MPU UART TIPB Bus Switch Registers	16
0xFFFE 0800	Ultra Low-Power Device (ULPD) Registers	16
0xFFFE 1000	OMAP5910 Configuration Registers	32
0xFFFE 1800	Device Die Identification Registers	32
0xFFFE C100	Local Bus Control Registers	32
0xFFFE C200	Local Bus MMU Registers	32
0xFFFE C900	MPU Interface (MPUI) Registers	32
0xFFFE CA00	TIPB (Private) Bridge 1 Config Registers	32
0xFFFE CC00	Traffic Controller Registers	32
0xFFFE CE00	MPU Clock/Reset/Power Control Registers	32
0xFFFE CF00	DPLL1 Configuration Registers	32
0xFFFE D200	DSP MMU Registers	32
0xFFFE D300	TIPB (Public) Bridge 2 Config Registers	16
0xFFFE D400	JTAG Identification Registers	32

3.3 DSP Memory Maps

The DSP supports a unified program/data memory map (program and data accesses are made to the same physical space), however peripheral registers are located in a separate I/O space which is accessed via the DSP's port instructions.

3.3.1 DSP Global Memory Map

The DSP Subsystem contains 160Kbytes of on-chip SRAM (64Kbytes DARAM and 96Kbytes SARAM). The MPU also has access to these memories via the MPUI (MPU Interface) port. The DSP also has access to the shared system SRAM (192Kbytes) and both EMIF spaces (EMIFF and EMIFS) via the DSP Memory Management Unit (MMU) which is configured by the MPU.

Table 3–7 shows the high-level program/data memory map for the DSP subsystem. DSP data accesses utilize 16-bit word addresses while DSP program fetches utilize byte addressing.

Table 3–7. DSP Global Memory Map

BYTE ADDRESS RANGE	WORD ADDRESS RANGE	INTERNAL MEMORY	EXTERNAL MEMORY†
0x00 0000 – 0x00 FFFF	0x00 0000 – 0x00 7FFF	DARAM 64K bytes	
0x01 0000 – 0x02 7FFF	0x00 8000 – 0x01 3FFF	SARAM 96K bytes	
0x02 8000 – 0x04 FFFF	0x01 4000 – 0x02 7FFF	Reserved	
0x05 0000 – 0xFF 7FFF	0x02 8000 – 0x7F BFFF		Managed by DSP MMU
0xFF 8000 – 0xFF FFFF	0x7F C000 – 0x7F FFFF	PDRAM (MPNMC = 0)	Managed by DSP MMU (MPNMC = 1)

† This space could be external memory or internal shared system memory depending on the DSP MMU configuration.

3.3.2 On-Chip Dual-Access RAM (DARAM)

The DARAM is located in the byte address range 000000h–00FFFFh and is composed of eight blocks of 8K bytes each (see Table 3–8). Each DARAM block can perform two accesses per cycle (two reads, two writes, or a read and a write).

Table 3–8. DARAM Blocks

BYTE ADDRESS RANGE	WORD ADDRESS RANGE	MEMORY BLOCK
0x00 0000 – 0x00 1FFF	0x00 0000 – 0x00 0FFF	DARAM 0
0x00 2000 – 0x00 3FFF	0x00 1000 – 0x00 1FFF	DARAM 1
0x00 4000 – 0x00 5FFF	0x00 2000 – 0x00 2FFF	DARAM 2
0x00 6000 – 0x00 7FFF	0x00 3000 – 0x00 3FFF	DARAM 3
0x00 8000 – 0x00 9FFF	0x00 4000 – 0x00 4FFF	DARAM 4
0x00 A000 – 0x00 BFFF	0x00 5000 – 0x00 5FFF	DARAM 5
0x00 C000 – 0x00 DFFF	0x00 6000 – 0x00 6FFF	DARAM 6
0x00 E000 – 0x00 FFFF	0x00 7000 – 0x00 7FFF	DARAM 7

3.3.3 On-Chip Single-Access RAM (SARAM)

The SARAM is located at the byte address range 010000h–03FFFFh and is composed of 12 blocks of 8K bytes each (see Table 3–9). Each SARAM block can perform one access per cycle (one read or one write).

Table 3–9. SARAM Blocks

BYTE ADDRESS RANGE	WORD ADDRESS RANGE	MEMORY BLOCK
0x01 0000 – 0x01 1FFF	0x00 8000 – 0x00 8FFF	SARAM 0
0x01 2000 – 0x01 3FFF	0x00 9000 – 0x00 9FFF	SARAM 1
0x01 4000 – 0x01 5FFF	0x00 A000 – 0x00 AFFF	SARAM 2
0x01 6000 – 0x01 7FFF	0x00 B000 – 0x00 BFFF	SARAM 3
0x01 8000 – 0x01 9FFF	0x00 C000 – 0x00 CFFF	SARAM 4
0x01 A000 – 0x01 BFFF	0x00 D000 – 0x00 DFFF	SARAM 5
0x01 C000 – 0x01 DFFF	0x00 E000 – 0x00 EFFF	SARAM 6
0x01 E000 – 0x01 FFFF	0x00 F000 – 0x00 FFFF	SARAM 7
0x02 0000 – 0x02 1FFF	0x01 0000 – 0x01 0FFF	SARAM 8
0x02 2000 – 0x02 3FFF	0x01 1000 – 0x01 1FFF	SARAM 9
0x02 4000 – 0x02 5FFF	0x01 2000 – 0x01 2FFF	SARAM 10
0x02 6000 – 0x02 7FFF	0x01 3000 – 0x01 3FFF	SARAM 11

3.3.4 DSP I/O Space Memory Map

The DSP I/O space is a separate address space from the data/program memory space. The I/O space is accessed via the DSP's port instructions. The Public and Shared peripheral registers are also accessible by the MPU through the MPUI (MPU Interface) port. The DSP I/O space is accessed using 16-bit word addresses. The following tables specify the DSP base addresses where each set of registers is accessed. All accesses to these registers must utilize the appropriate access width as indicated in the tables. Accessing registers with the incorrect access width may result in unexpected results including a TI Peripheral Bus (TIPB) bus error and associated TIPB interrupt.

Refer to Sections 3.16 and 3.17 for more detail about each of these register sets including individual register addresses, register names, descriptions, supported access types (read, write or read/write) and reset values.

Table 3–10. DSP Private Peripheral Registers

DSP BASE ADDRESS	REGISTER SET	ACCESS WIDTH
0x00 0C00	DSP DMA Controller Registers	16
0x00 2800	DSP Timer1 Registers	16
0x00 2C00	DSP Timer2 Registers	16
0x00 3000	DSP Timer3 Registers	16
0x00 3400	DSP Watchdog Timer Registers	16
0x00 3800	DSP Interrupt Interface Registers	16
0x00 4800	Level2 Interrupt Handler Registers	16

Table 3–11. DSP Public Peripheral Registers

DSP BASE ADDRESS	REGISTER SET	ACCESS WIDTH
0x00 8C00	McBSP1 Registers	16
0x00 9000	MCS12 Registers	16
0x00 9400	MCS11 Registers	16
0x00 B800	McBSP3 Registers	16

Table 3–12. DSP/MPU Shared Peripheral Registers

DSP BASE ADDRESS	REGISTER SET	ACCESS WIDTH
0x00 8000	UART1 Registers	8
0x00 8400	UART2 Registers	8
0x00 CC00	UART3 Registers	8
0x00 F000	GPIO Interface Registers	16
0x00 F800	Mailbox Registers	16

Table 3–13. DSP Configuration Registers

DSP BASE ADDRESS	REGISTER SET	ACCESS WIDTH
0x00 0000	DSP TIPB Bridge Config Registers	16
0x00 0800	DSP EMIF Config Registers	16
0x00 1400	DSP I-Cache Registers	16
0x00 4000	DSP Clock Mode Registers	16
0x00 E400	DSP UART TIPB Bus Switch Registers	16

3.4 DSP External Memory (Managed by MMU)

When the DSP MMU is off, the 24 address lines are directly copied to the traffic controller without any modification. There is no virtual-to-physical address translation. All the addresses between 0x05 0000 and 0x00FF F800 (0x00FF FFFF if DSP bit MP/MC = 1) are redirected to the first sector of flash (CS0) in the shared memory space (shared by MPU and DSP).

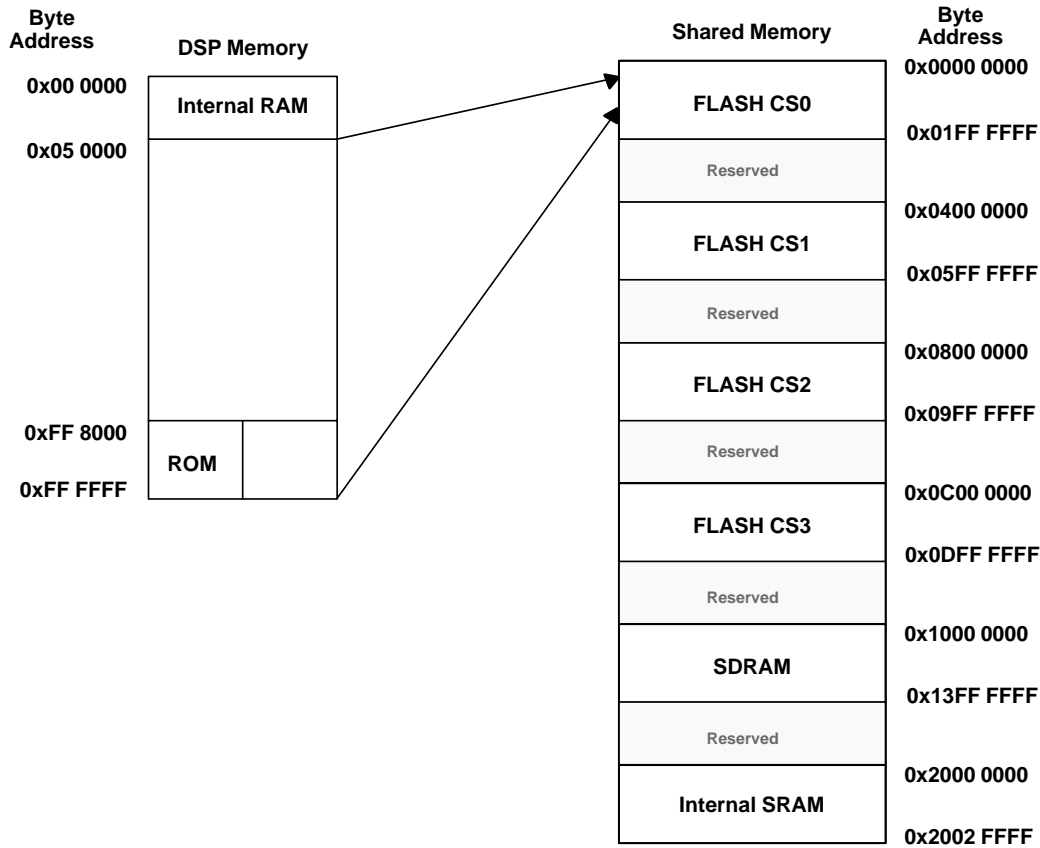

Figure 3–2. DSP MMU Off

PRODUCT PREVIEW

When the DSP MMU is on, the 24 address lines (virtual address) are relocated within a physical 32-bit address by the DSP MMU. The DSP MMU is controlled by the MPU.

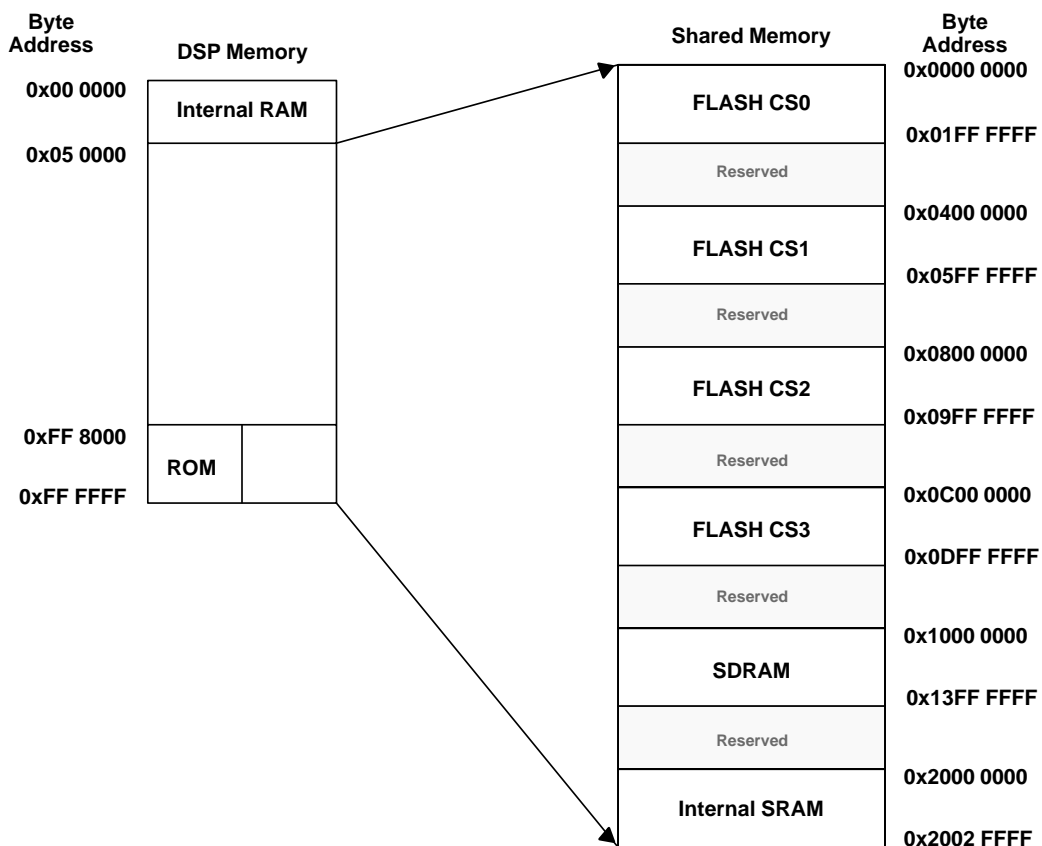

Figure 3-3. DSP MMU On

PRODUCT PREVIEW

3.5 MPU and DSP Private Peripherals

The MPU and DSP each have their own separate private peripheral bus. Peripherals on each of these private buses may only be accessed by their respective processors. For instance, the DSP timers on the DSP private peripheral bus are not accessible by the MPU or the System DMA controller.

3.5.1 Timers

The MPU and DSP each have their own three 32-bit timers available on their respective private TI Peripheral Bus (TIPB). These timers are used by the operating systems to provide general-purpose housekeeping functions, or in the case of the DSP, to also provide synchronization of real-time processing functions. These timers may be configured either in auto-reload or one-shot mode with on-the-fly read capability. The timers generate an interrupt to the respective processor (MPU or DSP) when the timer's down-counter is equal to zero.

3.5.2 32k Timer (MPU only)

The MPU has one 32k Timer that runs on the 32-kHz clock as opposed to the MPU subsystem domain clock.

The MPU subsystem operating system (OS) requires interrupts at regular time intervals for OS scheduling purpose (typically 1 ms to 30 ms). These time intervals can be generated using the MPU's three 32-bit general-purpose timers; however, these timers cannot be used in sleep modes when the system clock is not operating. Therefore, a 32-kHz clock-based timer is needed to provide the required OS timing interval.

3.5.3 Watchdog Timer

The MPU and DSP each have a single Watchdog Timer. Each watchdog timer can be configured as either a watchdog timer or a general-purpose timer.

A watchdog timer requires that the MPU or DSP software or OS periodically write to the appropriate WDT count register before the counter underflows. If the counter underflows, the WDT generates a reset to the appropriate processor (MPU or DSP). The DSP WDT resets only the DSP processor while the MPU WDT resets both processors (MPU and DSP). The watchdog timers are useful for detecting user programs that are stuck in an infinite loop, resulting in loss of program control or in a runaway condition.

When used as a general-purpose timer, the WDT is a 16-bit timer configurable either in autoreload or one-shot mode with on-the-fly read capability. The timer generates an interrupt to the respective processor (MPU or DSP) when the timer's down-counter is equal to zero.

3.5.4 Interrupt Handlers

The MPU and DSP each have two levels of interrupt handling, allowing up to 39 interrupts to the DSP and 63 interrupts to the MPU. This is necessary because of the large number of integrated peripherals on the OMAP5910 device.

3.5.5 LCD Controller

The OMAP5910 device includes an LCD Controller that interfaces with most industry-standard LCD displays. The LCD Controller is configured by the MPU and utilizes a dedicated channel on the System DMA to transfer data from the frame buffer. The frame buffer can be implemented using the internal shared SRAM (192K bytes) or optionally using external SDRAM via the EMIF. Using the frame buffer as its data source, the System DMA must provide data to the FIFO at the front end of the LCD controller data path at a rate sufficient to support the chosen display mode and resolution. Optimal performance is achieved when using the internal SRAM as the frame buffer.

The panel size is programmable, and can be any width (line length) from 16 to 1024 pixels in 16-pixel increments. The number of lines is set by programming the total number of pixels in the LCD. The total frame size is programmable up to 1024 x 1024; however, frame sizes and frame rates supported in specific applications will depend upon the available memory bandwidth allowed by the specific application as well as the maximum configurable pixel clock rate.

The screen is intended to be mapped to the frame buffer as one contiguous block where each horizontal line of pixels is mapped to a set of consecutive bytes of words in the frame memory.

The principle features of the LCD controller are:

- Dedicated 64-entry x 16-bit FIFO
- Dedicated LCD DMA channel for LCD display
- Programmable display including support for 2-, 4-, 8-, 12-, and 16-bit graphics modes
- Programmable display resolutions up to 1024 pixels by 1024 lines (assuming sufficient system bandwidth)
- Support for passive monochrome (STN) displays
- Support for passive color (STN) displays
- Support for active color (TFT) displays
- Patented dithering algorithm, providing:
 - 15 grayscale levels for monochrome passive displays
 - 3375 colors for color passive displays
 - 65536 colors for active color displays
 - 256-entry x 12-bit palette
- Programmable pixel rate
- Pixel clock plus horizontal and vertical synchronization signals
- ac-bias drive signal
- Active display enable signal

3.6 MPU Public Peripherals

Peripherals on the MPU Public Peripheral bus may only be accessed by the MPU and the System DMA Controller, which is configured by the MPU. This bus is called a public bus because it is accessible by the System DMA controller. The DSP cannot access peripherals on this bus.

3.6.1 USB1.1 Host Controller

The OMAP5910 USB host controller communicates with USB devices at the USB low-speed (1.5M-bit/s maximum) and full-speed (12M-bit/s maximum) data rates. The controller is compatible with the *Universal Serial Bus Specification, Revision 1.1* and the *OpenHCI – Open Host Controller Interface Specification for USB, Release 1.0a*, available through the Compaq Computer Corporation web site, and hereafter called the OHCI Specification for USB.

The OMAP5910 USB host controller implements the register set and makes use of the memory data structures which are defined in the OHCI Specification for USB. These registers and data structures are the mechanism by which a USB host controller driver software package may control the OMAP5910 USB host controller.

The USB host controller is connected to the MPU public peripheral bus for MPU access to registers. The USB host controller gains access to the data structures in system memory via the internal Local Bus interface. The OMAP5910 device implements a variety of signal multiplexing options that allows use of the USB host controller with any of the three available USB interfaces on the device. One of these interfaces utilizes an integrated USB transceiver, while the other two require external transceivers. The host controller can support up to three downstream ports.

The OMAP5910 USB host controller implementation does not implement every aspect of the functionality defined in the OHCI Specification for USB. The differences focus on power switching, overcurrent reporting, and the OHCI ownership change interrupt. Other restrictions are imposed by OMAP5910 system memory addressing mechanisms and the effects of the OMAP5910 pin-multiplexing options.

3.6.2 USB1.1 Function Peripheral

The USB Function peripheral provides a full-speed Function interface between the MPU and the USB wire. The module handles USB transactions with minimal MPU intervention and is fully compliant to USB 1.1 standard.

The USB Function module supports one control endpoint (EP0), up to 15 IN endpoints, and up to 15 OUT endpoints. The exact endpoint configuration is software-programmable. The specific items of a configuration for each endpoint are: the size in bytes, the direction (IN, OUT), the type (bulk/interrupt or isochronous), and the associated endpoint number. The USB Function module also supports the use of three System DMA channels for IN endpoints and three System DMA channels for OUT endpoints for either bulk/interrupt or isochronous transactions.

The OMAP5910 device implements a variety of signal-multiplexing options that allow use of the USB Function peripheral with any one of the three available USB interfaces on the device. One of these interfaces utilizes an integrated USB transceiver, while the other two require external transceivers. The USB Function can only utilize one of these ports at a time. The other ports may be used simultaneously by the USB Host controller peripheral.

3.6.3 Multichannel Buffered Serial Port (McBSP)

The Multichannel Buffered Serial Port (McBSP) provides a high-speed, full-duplex serial port that allow direct interface to audio codecs, and various other system devices. The MPU public peripheral bus has access to one McBSP, which is McBSP2.

The McBSP provides:

- Full-duplex communication
- Double-buffer data registers, which allow a continuous data stream
- Independent framing and clocking for receive and transmit

In addition, the McBSP has the following capabilities:

- Direct interface to:
 - T1/E1 framers
 - MVIP switching-compatible and ST-BUS compliant devices
 - IOM-2 compliant device
 - AC97-compliant device
 - I2S-compliant device
 - Serial peripheral interface (SPI)
- Multichannel transmit and receive of up to 128 channels
- A wide selection of data sizes, including: 8, 12, 16, 20, 24, or 32 bits
- μ -law and A-law companding
- Programmable polarity for both frame synchronization and data clocks
- Programmable internal clock and frame generation

NOTE: All of the standard McBSP pins are not necessarily available on every McBSP on the OMAP5910 device.

In the case of the MPU's McBSP2, the following pins are available:

- CLKX and CLKR (transmit and receive clocks)
- FSX and FSR (transmit and receive frame syncs)
- DX and RX (transmit and receive data)

The functional clock to the McBSP2 peripheral is configurable to the DPLL clock rate with a divider of 1, 2, 4, or 8.

McBSP2 does not have a CLKS external clock reference pin. Therefore, if the McBSP2 Sample Rate Generator (SRG) is used, the only reference clock available to the Sample Rate Generator is a programmable clock from the MPU domain.

3.6.4 I²C Master/Slave Interface

The I²C Master/Slave Interface is compliant to Philips *I²C-bus specification version 2.1* master bus. The I²C controller supports the multimaster mode, which allows more than one device capable of controlling the bus to be connected to it. Including the OMAP5910 device, each I²C device is recognized by a unique address and can operate as either transmitter or receiver, depending on the function of the device. In addition to being a transmitter or receiver, a device connected to the I²C bus™ can also be considered as master or slave when performing data transfers.

The I²C Interface supports the following features:

- Compliant to Philips *I²C-bus specification version 2.1*
- Support standard mode (up to 100K bits/s) and Fast mode (up to 400K bits/s)
- 7-bit and 10-bit device addressing modes
- General call
- Start/Restart/Stop
- Multimaster transmitter/slave receiver mode
- Multimaster receiver/slave transmitter mode
- Combined master transmit/receive and receive/transmit mode
- Built-in FIFO for buffered read or write
- Module enable/disable capability
- Programmable clock generation
- Supports use of two DMA channels

The I²C Interface does not support the following features:

- High-speed (HS) mode for transfer rates up to 3.4M bits
- C-bus compatibility mode

3.6.5 Microwire Serial Interface

The Microwire interface is a serial synchronous interface that can drive up to four serial external components. The interface is compatible with the Microwire standard and is seen as the master.

Microwire is typically used to transmit control and status information to external peripheral devices or to transmit data to or from small nonvolatile memories such as serial EEPROMs or serial Flash devices.

3.6.6 Multimedia Card/Secure Digital (MMC/SD) Interface

The MMC/SD Interface controller provides an interface to MMC or SD memory cards plus up to three serial SPI flash cards or other SPI devices. The controller handles MMC/SD or SPI transactions with minimal MPU intervention, allowing optional use of two system DMA channels for transfer of data.

The following combination of external devices is supported:

- One or more MMC memory cards sharing the same bus plus up to three devices with 8-bit SPI protocol interface (serial flash memories, etc.).
- One single SD memory card plus up to three devices with 8-bit SPI protocol interface.

NOTE: Other combinations such as two SD cards or one MMC card with one SD card are not supported.

The MPU software must manage transaction semantics, while the MMC/SD controller deals with MMC/SD protocol at the transmission level: packing data, adding the CRC, generating the start/end bit and checking for syntactical correctness. SD mode wide bus width is also supported.

¹I²C Bus is a trademark of Philips Electronics N.V.

When interfacing with 8-bit SPI devices, the MMC/SD module does not perform any MMC specific function, rather it provides a generic SPI interface. Several additional interface pins are utilized to provide the SPI clock and SPI chip selects.

3.6.7 HDQ/1-Wire Interface

This module allows implementation of both HDQ and the 1-Wire protocols. These protocols use a single wire to communicate between a master and a slave. The HDQ/1-Wire pin is open-drain and requires an external pullup resistor.

HDQ and 1-Wire interfaces can be found on commercially available battery management and power management devices. The interface can be used to send command and status information between OMAP5910 and such a battery or power management device.

3.6.8 Camera Interface

The camera interface is an 8-bit external port which may be used to accept data from an external camera sensor. The interface handles multiple image formats synchronized on vertical and horizontal synchronization signals. Data transfer to the camera interface may be done synchronously or asynchronously.

The camera interface module converts the 8-bit data transfers into 32-bit words and utilizes a 128-word buffer to facilitate efficient data transfer to memory. Data may be transferred from the camera interface buffer to internal memory by the System DMA controller or directly by the MPU. The interface may utilize an externally driven clock at rates up to 12 MHz or may optionally provide an output reference clock at rates of 6 MHz, 8 MHz, 9.6 MHz, 12 MHz, or 24 MHz.

3.6.9 MPUIO/Keyboard Interface

The MPUIO pins may be used as either general-purpose I/O for the MPU or as a Keyboard Interface to a 6 x 5 or 8 x 8 keypad array. If a 6 x 5 keypad array is implemented, the unused MPUIO pins may be used as GPIO. When used as GPIO, each pin may be configured individually as either an output or an input, and they may be individually configured to generate MPU interrupts based on a level change (falling or rising) after a debouncing process. These MPUIO interrupts may be used to wake up the device from deep-sleep mode using the 32-kHz clock.

The MPUIO pins may also be used as a keyboard interface. The keyboard interface provides the following pins:

- KB.R[7:0] input pins for row lines
- KB.C[7:0] output pins for column lines

To allow key-press detection, all input pins (KB.Rx) are pulled up to DV_{DD} and all output pins (KB.Cx) are driven low level. The KB.R[7:0] and KB.C[7:0] pins should be connected to an external keyboard matrix such that when a key on the matrix is pressed, the corresponding row and column lines are shorted together. Any action on a key generates an interrupt to the MPU, which then scans the column lines in a particular sequence to determine which key or keys have been pressed.

3.6.10 Pulse-Width Light (PWL)

The Pulse-Width Light (PWL) module provides control of the LCD or keypad backlighting by employing a random sequence generator. This voltage-level control technique decreases the spectral power at the modulator harmonic frequencies. The module uses a switchable 32-kHz clock.

3.6.11 Pulse-Width Tone (PWT)

The Pulse-Width Tone (PWT) module generates a modulated frequency signal for use with an external buzzer. The frequency is programmable between 349 Hz and 5276 Hz with 12 half-tone frequencies per octave. The volume level of the output is also programmable.

3.6.12 LED Pulse Generator

There are two separate LED Pulse Generator (LPG) modules. Each LPG module provides an output for an indication LED. The blinking period is programmable between 152 ms and 4 s or the LED can be switched on or off permanently.

3.6.13 Real-Time Clock

The Real-Time Clock (RTC) module provides an embedded RTC for use in applications which need to track real time. This peripheral is not an ultra-low-power module—meaning that the RTC module cannot be powered independently without powering the OMAP5910 MPU core. Therefore, if an ultra-low-power RTC is desired for a system application, an external RTC should be used.

The RTC module has the following features:

- Time information (seconds/minutes/hours) directly in BCD code
- Calendar information (day/month/year/day of the week) directly in BCD code up to year 2099
- Interrupts generation, periodically (1s/1m/1h/1d period) or at a precise time of the day (alarm function)
- 30-s time correction
- Oscillator frequency calibration

3.6.14 Frame Adjustment Counter

The frame adjustment counter (FAC) is a simple peripheral that counts the number of rising edges of one signal (start of frame interrupt of the USB Function) during a programmable number of rising edges of a second signal (transmit frame synchronization of McBSP2). The FAC may only be used with these specific USB Function and McBSP2 signals. The count value can be used by system-level software to adjust the duration of the two time domains with respect to each other to reduce overflow and underflow. If the data being transferred is audio data, this module can be part of a solution that reduces pops and clicks. The FAC module generates one second-level interrupt to the MPU.

3.7 DSP Public Peripherals

Peripherals on the DSP Public Peripheral bus are directly accessible by the DSP and DSP DMA. These peripherals may also be accessed by the MPU and System DMA Controller via the MPUI interface. The MPUI interface must be properly configured to allow this access.

3.7.1 Multichannel Buffered Serial Port (McBSP)

The Multichannel Buffered Serial Port (McBSP) provides a high-speed, full-duplex serial port that allow direct interface to audio codecs and various other system devices. Refer to Section 3.6.3 for a list of features provided by the McBSP. The DSP public peripheral bus has access to two McBSPs: McBSP1 and McBSP3.

NOTE: All of the standard McBSP pins are not necessarily available on every McBSP on the OMAP5910 device. In the case of the two DSP McBSPs, the following pins are available:

- McBSP1 pins:
 - CLKX (transmit clock)
 - FSX (transmit frame sync)
 - DX and DR (transmit and receive data)
 - CLKS (external reference to Sample Rate Generator)
- McBSP3 pins:
 - CLKX (transmit clock)
 - FSX (transmit frame sync)
 - DX and DR (transmit and receive data)

Because McBSP1 and McBSP3 do not have the CLKR and FSR pins available, the transmit clock and frame sync pins (CLKX and FSX) must be used for bit clock and frame synchronization on both the transmit and receive channels of these McBSPs.

The functional clock to the McBSP1 and McBSP3 is fixed at 12 MHz. The bit-clock rate for these McBSPs is therefore limited to 6 MHz.

Only McBSP1 has the CLKS pin available. If the Sample Rate Generator (SRG) is used on McBSP1, the reference clock to the SRG may be configured to be either an external reference provided on the CLKS pin, or the internal 12-MHz device clock. However, if the SRG is used on McBSP3, the only reference clock available to this SRG is the 12-MHz device clock as clock reference.

3.7.2 Multichannel Serial Interface (MCSI)

The multichannel serial interface (MCSI) provides flexible serial interface with multichannel transmission capability. The MCSI allows the DSP to access a variety of external devices, such as audio codecs and other types of analog converters. The DSP public peripheral bus has access to two MCSIs: MCSI1 and MCSI2. These MCSIs provide full-duplex transmission and master or slave clock control. All transmission parameters are configurable to cover the maximum number of operating conditions. The MCSIs have the following features:

- Master or slave clock control (transmission clock and frame synchronization pulse)
- Programmable transmission clock frequency (master mode) up to 6 MHz
- Reception clock frequency (slave mode) of up to 12 MHz
- Single-channel or multichannel (x16) frame structure
- Programmable word length: 3 to 16 bits
- Full-duplex transmission
- Programmable frame configuration
- Continuous or burst transmission
- Normal or alternate framing
- Normal or inverted frame and clock polarities
- Short or long frame pulse
- Programmable oversize frame length
- Programmable frame length
- Programmable interrupt occurrence time (TX and RX)
- Error detection with interrupt generation on wrong frame length
- System DMA support for both TX and RX data transfers

3.8 Shared Peripherals

The shared peripherals are connected to both the MPU Public Peripheral bus and the DSP Public Peripheral bus. In the case of the UARTs, these connections are achieved via a TI Peripheral Bus Switch, which must be configured to allow MPU or DSP access to the UARTs. The other shared peripherals have permanent connections to both public peripheral buses, although read and write accesses to each peripheral register may differ.

3.8.1 Universal Asynchronous Receiver/Transmitter (UART)

The OMAP5910 device has three Universal Asynchronous Receiver/Transmitter (UART) peripherals which are accessible on the DSP public and MPU public peripheral buses. A TI peripheral bus switch configured by the MPU allows either TIPB access to these UART peripherals. All three UARTs are standard 16C750-compatible UARTs implementing an asynchronous transfer protocol with various flow control options. Two of the three UARTs (UART1 and UART2) have autobaud capability to automatically determine and adjust to the baud rate of the external connected device. One of the UARTs (UART3) can function as a general UART or can optionally function as an IrDA interface.

The main features of the UART peripherals include:

- Selectable UART/autobaud modes
- Dual 64-entry FIFOs for received and transmitted data payload
- Programmable and selectable transmit and receive FIFO trigger levels for DMA and interrupt generation
- Programmable sleep mode
- Complete status-reporting capabilities in both normal and sleep mode
- Frequency prescaler values from 0 to 65535 to generate the appropriate baud rates
- Interrupt request generated if multiple System DMA requests
- Baud rate from 300 bits/s up to 1.5M bits/s
- Autobauding between 1200 bits/s and 115.2K bits/s
- Software/hardware flow control
- Programmable XON/XOFF characters
- Programmable auto-RTS and auto-CTS
- Programmable serial interface characteristics
- 5-, 6-, 7-, or 8-bit characters
- Even-, odd-, or no-parity bit generation and detection
- 1, 1.5, or 2 stop-bit generation
- False start bit detection
- Line break generation and detection
- Fully prioritized interrupt system controls
- Internal test and loopback capabilities
- Modem control functions (CTS, RTS, DSR, DTR)

NOTE: DSR and DTR are not available on UART1 and UART3.

The IrDA functions available on UARTx are as follows:

- Slow infrared (SIR) operations
- Framing error, cyclic redundancy check (CRC) error, abort pattern (SIR) detection
- 8-entry status FIFO (with selectable trigger levels) available to monitor frame length and frame errors

3.8.2 General-Purpose I/O (GPIO)

There are up to 14 shared GPIO pins on the OMAP5910 device which may be accessed and controlled by either the DSP public peripheral bus or the MPU public peripheral bus. Each GPIO pin is independently configurable to be used by either the DSP or MPU. The MPU controls which processor owns each GPIO pin by configuring a pin control register that only the MPU can access.

Each GPIO pin can be used as either an input or output pin with GPIO inputs being synchronized internally to a peripheral clock. GPIO inputs may also optionally be configured to generate an interrupt condition to the processor which owns the GPIO pin. The sense of the interrupt condition is configurable such that either a high-to-low or low-to-high transition causes the interrupt condition.

Some of the GPIO pins are multiplexed with other interface pins specific to other device peripherals. Refer to Table 2–2 to decide which GPIO pins are multiplexed with other peripheral signals.

3.8.3 Mailbox Registers

Four sets of shared mailbox registers are available for communication between the DSP and MPU. These registers are discussed further in Section 3.12, Interprocessor Communication.

3.9 System DMA Controller

The System Direct Memory Access (DMA) controller transfers data between points in the memory space without intervention by the MPU. The System DMA allows movements of data to and from internal memory, external memory, and peripherals to occur in the background of MPU operation. It is designed to off-load the block data transfer function from the MPU processor. The System DMA is configured by the MPU via the MPU private peripheral bus.

The System DMA controller has nine independent general-purpose channels and seven ports that it may transfer to/from. An additional tenth channel is dedicated for use with the LCD controller. Of the seven available ports, the DMA transfers may occur between any two ports with the exception of the LCD port, which may only be used as a destination with the EMIFF or IMIF as the source. For maximum transfer efficiency, all nine channels are independent. This means that if multiple channels are exclusively accessing different ports, then simultaneous transfers performed by the channels will occur uninhibited. If the multiple channels are accessing common ports, however, some arbitration cycles will be necessary. Arbitration occurs in a round-robin fashion with configurable priority for each channel (high or low).

The basic functional features of the system DMA controller are as follows:

- Nine general-purpose and one dedicated (LCD) DMA channels
- Round-robin arbitration scheme with programmable priorities
- Concurrent DMA transfer capability
- Start of transfer on peripheral request or host request
- Byte-alignment and Byte-packing/unpacking capability
- Burst transfer capability (except for TIPB accesses)
- Time-out counter for each DMA channel to prevent a channel locking on a memory location or peripheral.
- Constant, post-incrementing, and Single- or Double-Indexed addressing modes
- Autoinitialization for multiple block transfers without MPU intervention
- Access available to all of the memory range (physical memory mapping and TIPB space)
- Seven ports available for different kinds of hardware resources. All of the ports except the TIPB have burst-access capability.
- EMIFS port (allowing access to external asynchronous memory or devices)
 - EMIFF port (allowing access to external SDRAM)
 - IMIF port (allowing access to 192K bytes of shared SRAM)
 - MPUI port (allowing access to DSP memory and peripherals)
 - TIPB port (allowing peripheral register access)
 - Local port (used for Host USB only)
 - LCD port (allowing transfers to the LCD controller)
- Memory-to-memory transfer granularity of 8, 16, and 32 bits with only the number of programmed bytes transferred; that is, there are no trailing or dirty bytes at the end of transfer.

3.10 DSP DMA Controller

The DSP subsystem has its own dedicated DMA Controller, which is entirely independent of the MPU or the System DMA Controller. The DSP DMA Controller has many of the same major features that the System DMA Controller possesses (see Section 3.9).

The DSP DMA Controller has six generic channels and five physical ports available for source or destination data. These five ports are the SARAM port, DARAM port, EMIF (External memory port), DSP TIPB port, and MPUI port. The DSP may configure the DSP DMA Controller to transfer data between the SARAM, DARAM, EMIF, and TIPB ports, but the MPUI port is a dedicated port used for MPU or System DMA initiated transfers to DSP subsystem resources. The SARAM and DARAM ports are used to access local DSP memories and the TIPB port is used to access the registers of the DSP peripherals. The EMIF port of the DSP DMA controller is used to access the Traffic Controller via the DSP MMU (Memory Management Unit).

3.11 Traffic Controller (Memory Interfaces)

The Traffic Controller (TC) manages all accesses by the MPU, DSP, System DMA, and Local Bus to the OMAP5910 system memory resources. The TC provides access to three different memory interfaces: External Memory Interface Slow (EMIFS), External Memory Interface Fast (EMIFF), and Internal Memory Interface (IMIF). The IMIF allows access to the 192K bytes of on-chip system memory (SRAM).

The EMIFS Interface provides 16-bit-wide access to asynchronous or synchronous memories or devices, including the following:

- Intel™ fast boot block flash (23FxxxF3)
- AMD™ simultaneous read/write boot sector flash (AM29DLxxxG)
- AMD burst-mode flash (AM29BLxxxC)
- Intel StrataFlash™ memory (28FxxxJ3A)
- Intel synchronous StrataFlash memory (28FxxxK3/K18)
- Intel wireless flash memory (28FxxxW18)
- Asynchronous SRAM

The EMIFF Interface provides access to 16-bit-wide access to standard SDRAM memories and the IMIF provides access to the 192K bytes of on-chip SRAM (system memory).

The TC provides the functions of arbitrating contending accesses to the same memory interface from different initiators (MPU, DSP, System DMA, Local Bus), synchronization of accesses due to the initiators and the memory interfaces running at different clock rates, and the buffering of data allowing burst access for more efficient multiplexing of transfers from multiple initiators to the memory interfaces.

The TC's architecture allows simultaneous transfers between initiators and different memory interfaces without penalty. For instance, if the MPU is accessing the EMIFF at the same time, the DSP is accessing the IMIF, transfers may occur simultaneously since there is no contention for resources. There are three separate ports to the TC from the System DMA (one for each of the memory interfaces), allowing for greater bandwidth capability between the System DMA and the TC.

Intel and Intel StrataFlash are trademarks or registered trademarks of Intel Corporation or its subsidiaries in the United States and other countries. AMD is a trademark of Advanced Micro Devices, Inc.

3.12 Interprocessor Communication

Several mechanisms allow for communication between the MPU and the DSP on the OMAP5910 device. These include mailbox registers, MPU Interface, and shared memory space.

3.12.1 MPU/DSP Mailbox Registers

The MPU and DSP processors may communicate with each other via a mailbox-interrupt mechanism. This mechanism provides a very flexible software protocol between the processors. There are four sets of mailbox registers located in public TIPB space. The registers are shared between the two processors, so the MPU and DSP may both access these registers within their own public TIPB space, but read/write accessibility of each register is different for each processor.

There are four sets of mailbox registers: two for the MPU to send messages and issue an interrupt to the DSP, the other two for the DSP to send messages and issue an interrupt to the MPU. Each set of mailbox registers consists of two 16-bit registers and a 1-bit flag register. The interrupting processor can use one 16-bit register to pass a data word to the interrupted processor and the other 16-bit register to pass a command word.

Communication is achieved when one processor writes to the appropriate command word register which causes an interrupt to the other processor and sets the appropriate flag register. The interrupted processor acknowledges by reading the command word which causes the flag register to be cleared. An additional data-word register is also available in each mailbox register set to optionally communicate two words of data between the processors for each interrupt instead of just communicating the command word.

The information communicated by the command and data words are entirely user-defined. The data word may be optionally used to indicate an address pointer or status word.

3.12.2 MPU Interface (MPUI)

The MPU interface (MPUI) allows the MPU and the system DMA controller to communicate with the DSP and its peripherals. The MPUI allows access to the full memory space (16M bytes) of the DSP and the DSP public peripheral bus. Thus, the MPU and System DMA Controller both have read and write access to the complete DSP I/O space (128K bytes), including the control registers of the DSP public peripherals.

The MPUI port supports the following features:

- Four access modes:
 - Shared-access mode (SAM) for MPU access of DSP SARAM, DARAM, and external memory interface
 - Shared-access mode (SAM) for peripheral bus access
 - Host-only mode (HOM) for SARAM access
 - Host-only mode (HOM) for peripheral bus access
- Interrupt to MPU if access time-out occurs
- Programmable priority scheme (MPU vs. DMA)
- Packing and unpacking of data (16 bits to 32 bits, and vice versa)
- 32-bit single access support
- Software control endianness conversion
- System DMA capability to full memory space (16M bytes)
- System DMA capability to the DSP public TIPB peripherals (up to 128K bytes space)

This port can be used for many functions, such as: MPU loading of program code into DSP program memory space, sharing of data between MPU and DSP, implementing interprocessing communication protocols via shared memory, or allowing MPU to use and control DSP Public TIPB Peripherals.

3.12.3 MPU/DSP Shared Memory

The OMAP5910 device implements a shared memory architecture via the Traffic Controller. Therefore, the MPU and DSP both have access to the same shared SRAM memory (192K bytes) as well as to the EMIFF and EMIFS memory space. Through the DSP Memory Management Unit (MMU), the MPU controls which regions of shared memory space the DSP is allowed to access. By setting up regions of shared memory, and defining a protocol for the MPU and DSP to access this shared memory, an interprocessor communication mechanism may be implemented. This method may be used in conjunction with the mailbox registers to create handshaking interrupts which will properly synchronize the MPU and DSP accesses to shared memory. Utilizing the shared memory in this fashion may be useful when the desired data to be passed between the MPU and DSP is larger than the two 16-bit words provided by each set of mailbox command and data registers.

For example, the MPU may need to provide the DSP with a list of pointers to perform a specific task as opposed to a single command and single pointer. Using shared memory and the mailboxes, the DSP could read the list of pointers from shared memory after receiving the interrupt caused by an MPU write to the mailbox command register.

3.13 DSP Hardware Accelerators

The TMS320C55x DSP core within the OMAP5910 device utilizes three powerful hardware accelerator modules which assist the DSP core in implementing specific algorithms that are commonly used in video compression applications such as MPEG4 encoders/decoders. These accelerators allow implementation of such algorithms using fewer DSP instruction cycles and dissipating less power than implementations using only the DSP core. The hardware accelerators are utilized via functions from the TMS320C55x Image/Video Processing Library available from Texas Instruments.

Utilizing the hardware accelerators, the Texas Instruments Image/Video Processing Library implements many useful functions, which include the following:

- Forward and Inverse Discrete Cosine Transform (DCT) (used for video compression/decompression)
- Motion Estimation (used for compression standards such as MPEG video encoding and H.26x encoding)
- Pixel Interpolation (enabling high-performance fractal-pixel motion estimation)
- Quantization/Dequantization (useful for JPEG, MPEG, H.26x Encoding/Decoding)
- Flexible 1D/2D Wavelet Processing (useful for JPEG2000, MPEG4, and other compression standards)
- Boundary and Perimeter Computation (useful for Machine Vision applications)
- Image Threshold and Histogram Computations (useful for various Image Analysis applications)

3.13.1 DCT/iDCT Accelerator

The DCT/iDCT hardware accelerator is used to implement Forward and Inverse DCT (Discrete Cosine Transform) algorithms. These DCT/iDCT algorithms can be used to implement a wide range of video compression standards including JPEG Encode/Decode, MPEG Video Encode/Decode, and H.26x Encode/Decode.

3.13.2 Motion Estimation Accelerator

The Motion Estimation hardware accelerator implements a high-performance motion estimation algorithm, enabling MPEG Video encoder or H.26x encoder applications. Motion estimation is typically one of the most computation-intensive operations in video-encoding systems.

3.13.3 Pixel Interpolation Accelerator

The Pixel Interpolation Accelerator enables high-performance pixel-interpolation algorithms, which allows for powerful fractal pixel motion estimation when used in conjunction with the Motion Estimation accelerator. Such algorithms provide significant improvement to video-encoding applications.

3.14 Power Supply Connection Examples

The OMAP5910 device is extremely flexible regarding the implementation of the core and I/O voltage supplies of the device.

In a typical system, all of the core voltage supplies (CVDDx) may be connected together and powered from one common supply. Likewise, all of the I/O voltage supplies (DVDDx) may be connected together and powered from a common supply. Figure 3–4 illustrates this common system configuration.

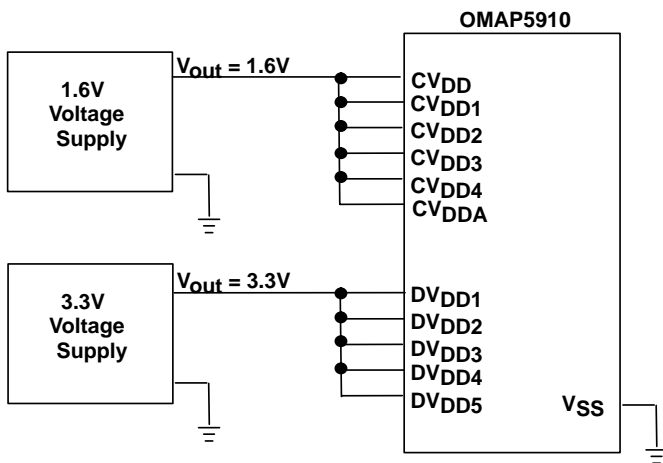

Figure 3–4. Supply Connections for a Typical System

Several of the I/O voltage supplies (DVDD3, DVDD4 and DVDD5) are capable of operating at lower voltages (1.8V nominal) while the other I/O supplies run at 3.3V nominal. This is advantageous for systems which mix standard 3.3V devices with low voltage memory devices or other low voltage logic. Refer to Table 2–2 to determine which I/O pins are powered by each of the DVDDx supplies. Figure 3–5 illustrates an example of this type of mixed voltage system configuration.

PRODUCT PREVIEW

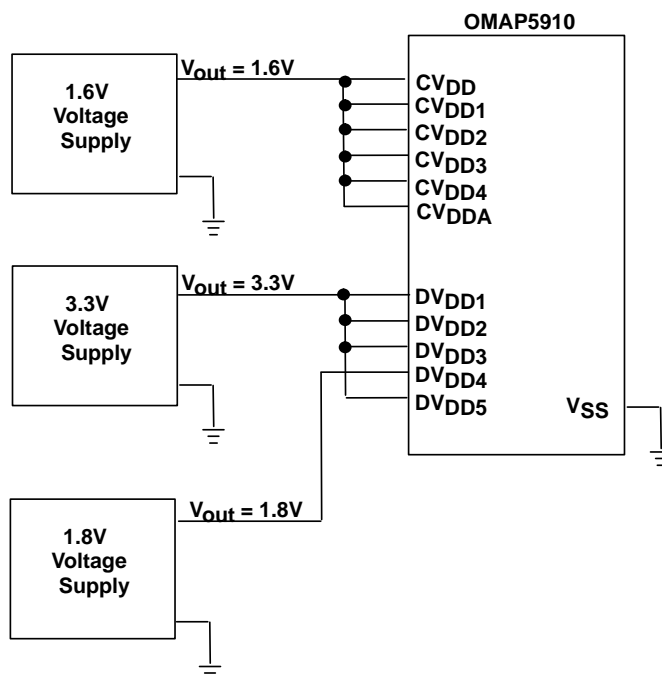

Figure 3-5. Supply Connections for a System with 1.8-V SDRAM

In the previous two examples, all CVDDx pins are connected in common. However, the OMAP5910 device has dedicated CVDD pins which supply power to different sections of the chip (as described in Table 2-3, Signal Descriptions). This feature could be useful in prototyping phases to troubleshoot power management features and perform advanced power. By isolating each CVDDx bus from the power source through isolation jumpers or current sense resistors, the current draw into different domains may be measured separately. This type of supply isolation should only be done during prototyping as production system designs should connect all the CVDDx pins together, preferably to a common board plane.

NOTE: There is no specific power sequencing for the different voltage supplies as long as all CVDDx and DVDDx voltages are ramped to valid operating levels within 500ms of one another. Additionally, if certain I/O pins are unused in a specific system application, the DVDDx supply pins which power these I/O must still be connected to valid operating voltage levels. See Section 5.2, *Recommended Operating Conditions*, for complete voltage requirements on all CVDDx and DVDDx power supply pins.

3.15 MPU Register Descriptions

The following tables describe the MPU registers including register addresses, descriptions, required access widths, access types (R = read, W = write, RW = read/write) and reset values. These tables are organized by function with like peripherals or functions together and are therefore not necessarily in the order of ascending register addresses.

NOTE: All accesses to these registers must be of the data access widths indicated to avoid a TIPB bus error condition and a corresponding interrupt. Reserved addresses should never be accessed.

3.15.1 MPU Private Peripheral Registers

The MPU private peripheral registers include the following:

- Timers
 - MPU Timer 1 Register
 - MPU Timer 2 Registers
 - MPU Timer 3 Registers
 - MPU Watchdog Timer Registers
- Interrupt Handlers
 - MPU Level 1 Interrupt Handler Registers
 - MPU Level 2 Interrupt Handler Registers
- System Peripherals
 - System DMA Controller Registers
 - LCD Controller Registers

Table 3–14. MPU Timer 1 Registers

BYTE ADDRESS	REGISTER NAME	DESCRIPTION	ACCESS WIDTH	ACCESS TYPE	RESET VALUE
FFFE:C500	MPU_CNTL_TIMER_1	MPU Timer 1 Control Timer Register	32	RW	0000 0000h
FFFE:C504	MPU_LOAD_TIM_1	MPU Timer 1 Load Timer Register	32	W	undef
FFFE:C508	MPU_READ_TIM_1	MPU Timer 1 Read Timer Register	32	R	undef

Table 3–15. MPU Timer 2 Registers

BYTE ADDRESS	REGISTER NAME	DESCRIPTION	ACCESS WIDTH	ACCESS TYPE	RESET VALUE
FFFE:C600	MPU_CNTL_TIMER_2	MPU Timer 2 Control Timer Register	32	RW	0000 0000h
FFFE:C604	MPU_LOAD_TIM_2	MPU Timer 2 Load Timer Register	32	W	undef
FFFE:C608	MPU_READ_TIM_2	MPU Timer 2 Read Timer Register	32	R	undef

Table 3–16. MPU Timer 3 Registers

BYTE ADDRESS	REGISTER NAME	DESCRIPTION	ACCESS WIDTH	ACCESS TYPE	RESET VALUE
FFFE:C700	MPU_CNTL_TIMER_3	MPU Timer 3 Control Timer Register	32	RW	0000 0000h
FFFE:C704	MPU_LOAD_TIM_3	MPU Timer 3 Load Timer Register	32	W	undef
FFFE:C708	MPU_READ_TIM_3	MPU Timer 3 Read Timer Register	32	R	undef

Table 3–17. MPU Watchdog Timer Registers

BYTE ADDRESS	REGISTER NAME	DESCRIPTION	ACCESS WIDTH	ACCESS TYPE	RESET VALUE
FFFE:C800	MPU_CNTL_TIMER_WD	MPU WDT Control Timer Register	32	RW	0002h
FFFE:C804	MPU_LOAD_TIM_WD	MPU WDT Load Timer Register	32	W	FFFFh
FFFE:C808	MPU_READ_TIM_WD	MPU WDT Read Timer Register	32	R	FFFFh
FFFE:C80C	MPU_TIMER_MODE_WD	MPU WDT Timer Mode Register	32	RW	8000h

PRODUCT PREVIEW

Table 3–18. MPU Level 1 Interrupt Handler Registers

BYTE ADDRESS	REGISTER NAME	DESCRIPTION	ACCESS WIDTH	ACCESS TYPE	RESET VALUE
FFFE:CB00	MPU_L1_ITR	Interrupt Register	32	RW	0000 0000h
FFFE:CB04	MPU_L1_MIR	Mask Interrupt Register	32	RW	FFFF FFFFh
FFFE:CB08 – FFFE:CB0C		Reserved			
FFFE:CB10	MPU_L1_SIR_IRQ_CODE	IRQ Interrupt Encoded Source Register	32	R	0000 0000h
FFFE:CB14	MPU_L1_SIR_FIQ_CODE	FIQ Interrupt Encoded Source Register	32	R	0000 0000h
FFFE:CB18	MPU_L1_CONTROL_REG	Interrupt Control Register	32	RW	0000 0000h
FFFE:CB1C	MPU_L1_ILR0	Interrupt 0 Priority Level Register	32	RW	0000 0000h
FFFE:CB20	MPU_L1_ILR1	Interrupt 1 Priority Level Register	32	RW	0000 0000h
FFFE:CB24	MPU_L1_ILR2	Interrupt 2 Priority Level Register	32	RW	0000 0000h
FFFE:CB28	MPU_L1_ILR3	Interrupt 3 Priority Level Register	32	RW	0000 0000h
FFFE:CB2C	MPU_L1_ILR4	Interrupt 4 Priority Level Register	32	RW	0000 0000h
FFFE:CB30	MPU_L1_ILR5	Interrupt 5 Priority Level Register	32	RW	0000 0000h
FFFE:CB34	MPU_L1_ILR6	Interrupt 6 Priority Level Register	32	RW	0000 0000h
FFFE:CB38	MPU_L1_ILR7	Interrupt 7 Priority Level Register	32	RW	0000 0000h
FFFE:CB3C	MPU_L1_ILR8	Interrupt 8 Priority Level Register	32	RW	0000 0000h
FFFE:CB40	MPU_L1_ILR9	Interrupt 9 Priority Level Register	32	RW	0000 0000h
FFFE:CB44	MPU_L1_ILR10	Interrupt 10 Priority Level Register	32	RW	0000 0000h
FFFE:CB48	MPU_L1_ILR11	Interrupt 11 Priority Level Register	32	RW	0000 0000h
FFFE:CB4C	MPU_L1_ILR12	Interrupt 12 Priority Level Register	32	RW	0000 0000h
FFFE:CB50	MPU_L1_ILR13	Interrupt 13 Priority Level Register	32	RW	0000 0000h
FFFE:CB54	MPU_L1_ILR14	Interrupt 14 Priority Level Register	32	RW	0000 0000h
FFFE:CB58	MPU_L1_ILR15	Interrupt 15 Priority Level Register	32	RW	0000 0000h
FFFE:CB5C	MPU_L1_ILR16	Interrupt 16 Priority Level Register	32	RW	0000 0000h
FFFE:CB60	MPU_L1_ILR17	Interrupt 17 Priority Level Register	32	RW	0000 0000h
FFFE:CB64	MPU_L1_ILR18	Interrupt 18 Priority Level Register	32	RW	0000 0000h
FFFE:CB68	MPU_L1_ILR19	Interrupt 19 Priority Level Register	32	RW	0000 0000h
FFFE:CB6C	MPU_L1_ILR20	Interrupt 20 Priority Level Register	32	RW	0000 0000h
FFFE:CB70	MPU_L1_ILR21	Interrupt 21 Priority Level Register	32	RW	0000 0000h
FFFE:CB74	MPU_L1_ILR22	Interrupt 22 Priority Level Register	32	RW	0000 0000h
FFFE:CB78	MPU_L1_ILR23	Interrupt 23 Priority Level Register	32	RW	0000 0000h
FFFE:CB7C	MPU_L1_ILR24	Interrupt 24 Priority Level Register	32	RW	0000 0000h
FFFE:CB80	MPU_L1_ILR25	Interrupt 25 Priority Level Register	32	RW	0000 0000h
FFFE:CB84	MPU_L1_ILR26	Interrupt 26 Priority Level Register	32	RW	0000 0000h
FFFE:CB88	MPU_L1_ILR27	Interrupt 27 Priority Level Register	32	RW	0000 0000h
FFFE:CB8C	MPU_L1_ILR28	Interrupt 28 Priority Level Register	32	RW	0000 0000h
FFFE:CB90	MPU_L1_ILR29	Interrupt 29 Priority Level Register	32	RW	0000 0000h
FFFE:CB94	MPU_L1_ILR30	Interrupt 30 Priority Level Register	32	RW	0000 0000h
FFFE:CB98	MPU_L1_ILR31	Interrupt 31 Priority Level Register	32	RW	0000 0000h
FFFE:CB9C	MPU_L1_ISR	Software Interrupt Set Register	32	RW	0000 0000h

PRODUCT PREVIEW

Table 3–19. MPU Level 2 Interrupt Handler Registers

BYTE ADDRESS	REGISTER NAME	DESCRIPTION	ACCESS WIDTH	ACCESS TYPE	RESET VALUE
FFFE:0000	MPU_L2_ITR	Interrupt Register	32	RW	0000 0000h
FFFE:0004	MPU_L2_MIR	Mask Interrupt Register	32	RW	FFFF FFFFh
FFFE:0008 – FFFE:000C		Reserved			
FFFE:0010	MPU_L2_SIR_IRQ_CODE	IRQ Interrupt Encoded Source Register	32	R	0000 0000h
FFFE:0014	MPU_L2_SIR_FIQ_CODE	FIQ Interrupt Encoded Source Register	32	R	0000 0000h
FFFE:0018	MPU_L2_CONTROL_REG	Interrupt Control Register	32	RW	0000 0000h
FFFE:001C	MPU_L2_ILR0	Interrupt 0 Priority Level Register	32	RW	0000 0000h
FFFE:0020	MPU_L2_ILR1	Interrupt 1 Priority Level Register	32	RW	0000 0000h
FFFE:0024	MPU_L2_ILR2	Interrupt 2 Priority Level Register	32	RW	0000 0000h
FFFE:0028	MPU_L2_ILR3	Interrupt 3 Priority Level Register	32	RW	0000 0000h
FFFE:002C	MPU_L2_ILR4	Interrupt 4 Priority Level Register	32	RW	0000 0000h
FFFE:0030	MPU_L2_ILR5	Interrupt 5 Priority Level Register	32	RW	0000 0000h
FFFE:0034	MPU_L2_ILR6	Interrupt 6 Priority Level Register	32	RW	0000 0000h
FFFE:0038	MPU_L2_ILR7	Interrupt 7 Priority Level Register	32	RW	0000 0000h
FFFE:003C	MPU_L2_ILR8	Interrupt 8 Priority Level Register	32	RW	0000 0000h
FFFE:0040	MPU_L2_ILR9	Interrupt 9 Priority Level Register	32	RW	0000 0000h
FFFE:0044	MPU_L2_ILR10	Interrupt 10 Priority Level Register	32	RW	0000 0000h
FFFE:0048	MPU_L2_ILR11	Interrupt 11 Priority Level Register	32	RW	0000 0000h
FFFE:004C	MPU_L2_ILR12	Interrupt 12 Priority Level Register	32	RW	0000 0000h
FFFE:0050	MPU_L2_ILR13	Interrupt 13 Priority Level Register	32	RW	0000 0000h
FFFE:0054	MPU_L2_ILR14	Interrupt 14 Priority Level Register	32	RW	0000 0000h
FFFE:0058	MPU_L2_ILR15	Interrupt 15 Priority Level Register	32	RW	0000 0000h
FFFE:005C	MPU_L2_ILR16	Interrupt 16 Priority Level Register	32	RW	0000 0000h
FFFE:0060	MPU_L2_ILR17	Interrupt 17 Priority Level Register	32	RW	0000 0000h
FFFE:0064	MPU_L2_ILR18	Interrupt 18 Priority Level Register	32	RW	0000 0000h
FFFE:0068	MPU_L2_ILR19	Interrupt 19 Priority Level Register	32	RW	0000 0000h
FFFE:006C	MPU_L2_ILR20	Interrupt 20 Priority Level Register	32	RW	0000 0000h
FFFE:0070	MPU_L2_ILR21	Interrupt 21 Priority Level Register	32	RW	0000 0000h
FFFE:0074	MPU_L2_ILR22	Interrupt 22 Priority Level Register	32	RW	0000 0000h
FFFE:0078	MPU_L2_ILR23	Interrupt 23 Priority Level Register	32	RW	0000 0000h
FFFE:007C	MPU_L2_ILR24	Interrupt 24 Priority Level Register	32	RW	0000 0000h
FFFE:0080	MPU_L2_ILR25	Interrupt 25 Priority Level Register	32	RW	0000 0000h
FFFE:0084	MPU_L2_ILR26	Interrupt 26 Priority Level Register	32	RW	0000 0000h
FFFE:0088	MPU_L2_ILR27	Interrupt 27 Priority Level Register	32	RW	0000 0000h
FFFE:008C	MPU_L2_ILR28	Interrupt 28 Priority Level Register	32	RW	0000 0000h
FFFE:0090	MPU_L2_ILR29	Interrupt 29 Priority Level Register	32	RW	0000 0000h
FFFE:0094	MPU_L2_ILR30	Interrupt 30 Priority Level Register	32	RW	0000 0000h
FFFE:0098	MPU_L2_ILR31	Interrupt 31 Priority Level Register	32	RW	0000 0000h
FFFE:009C	MPU_L2_ISR	Software Interrupt Set Register	32	RW	0000 0000h

PRODUCT PREVIEW

Table 3–20. System DMA Controller Registers

BYTE ADDRESS	REGISTER NAME	DESCRIPTION	ACCESS WIDTH	ACCESS TYPE	RESET VALUE
FFFE:D800	SYS_DMA_CSDP_CH0	Channel 0 Source/Destination Parameters Register	16	RW	0000h
FFFE:D802	SYS_DMA_CCR_CH0	Channel 0 Control Register	16	RW	0000h
FFFE:D804	SYS_DMA_CICR_CH0	Channel 0 Interrupt Control Register	16	RW	0003h
FFFE:D806	SYS_DMA_CSR_CH0	Channel 0 Status Register	16	R	0000h
FFFE:D808	SYS_DMA_CSSA_L_CH0	Channel 0 Source Start Address Register LSB	16	RW	undef
FFFE:D80A	SYS_DMA_CSSA_U_CH0	Channel 0 Source Start Address Register MSB	16	RW	undef
FFFE:D80C	SYS_DMA_CDSA_L_CH0	Channel 0 Destination Start Address Register LSB	16	RW	undef
FFFE:D80E	SYS_DMA_CDSA_U_CH0	Channel 0 Destination Start Address Register MSB	16	RW	undef
FFFE:D810	SYS_DMA_CEN_CH0	Channel 0 Element Number Register	16	RW	undef
FFFE:D812	SYS_DMA_CFN_CH0	Channel 0 Frame Number Register	16	RW	undef
FFFE:D814	SYS_DMA_CFI_CH0	Channel 0 Frame Index Register	16	RW	undef
FFFE:D816	SYS_DMA_CEI_CH0	Channel 0 Element Index Register	16	RW	undef
FFFE:D818	SYS_DMA_CPC_CH0	Channel 0 Progress Counter Register	16	RW	undef
FFFE:D81A – FFFE:083E		Reserved			
FFFE:D840	SYS_DMA_CSDP_CH1	Channel 1 Source/Destination Parameters Register	16	RW	0000h
FFFE:D842	SYS_DMA_CCR_CH1	Channel 1 Control Register	16	RW	0000h
FFFE:D844	SYS_DMA_CICR_CH1	Channel 1 Interrupt Control Register	16	RW	0003h
FFFE:D846	SYS_DMA_CSR_CH1	Channel 1 Status Register	16	R	0000h
FFFE:D848	SYS_DMA_CSSA_L_CH1	Channel 1 Source Start Address Register LSB	16	RW	undef
FFFE:D84A	SYS_DMA_CSSA_U_CH1	Channel 1 Source Start Address Register MSB	16	RW	undef
FFFE:D84C	SYS_DMA_CDSA_L_CH1	Channel 1 Destination Start Address Register LSB	16	RW	undef
FFFE:D84E	SYS_DMA_CDSA_U_CH1	Channel 1 Destination Start Address Register MSB	16	RW	undef
FFFE:D850	SYS_DMA_CEN_CH1	Channel 1 Element Number Register	16	RW	undef
FFFE:D852	SYS_DMA_CFN_CH1	Channel 1 Frame Number Register	16	RW	undef
FFFE:D854	SYS_DMA_CFI_CH1	Channel 1 Frame Index Register	16	RW	undef
FFFE:D856	SYS_DMA_CEI_CH1	Channel 1 Element Index Register	16	RW	undef
FFFE:D858	SYS_DMA_CPC_CH1	Channel 1 Progress Counter Register	16	RW	undef
FFFE:D85A – FFFE:D87E		Reserved			
FFFE:D880	SYS_DMA_CSDP_CH2	Channel 2 Source/Destination Parameters Register	16	RW	0000h
FFFE:D882	SYS_DMA_CCR_CH2	Channel 2 Control Register	16	RW	0000h
FFFE:D884	SYS_DMA_CICR_CH2	Channel 2 Interrupt Control Register	16	RW	0003h
FFFE:D886	SYS_DMA_CSR_CH2	Channel 2 Status Register	16	R	0000h
FFFE:D888	SYS_DMA_CSSA_L_CH2	Channel 2 Source Start Address Register LSB	16	RW	undef
FFFE:D88A	SYS_DMA_CSSA_U_CH2	Channel 2 Source Start Address Register MSB	16	RW	undef
FFFE:D88C	SYS_DMA_CDSA_L_CH2	Channel 2 Destination Start Address Register LSB	16	RW	undef
FFFE:D88E	SYS_DMA_CDSA_U_CH2	Channel 2 Destination Start Address Register MSB	16	RW	undef
FFFE:D890	SYS_DMA_CEN_CH2	Channel 2 Element Number Register	16	RW	undef
FFFE:D892	SYS_DMA_CFN_CH2	Channel 2 Frame Number Register	16	RW	undef
FFFE:D894	SYS_DMA_CFI_CH2	Channel 2 Frame Index Register	16	RW	undef
FFFE:D896	SYS_DMA_CEI_CH2	Channel 2 Element Index Register	16	RW	undef
FFFE:D898	SYS_DMA_CPC_CH2	Channel 2 Progress Counter Register	16	RW	undef

Table 3–20. System DMA Controller Registers (Continued)

BYTE ADDRESS	REGISTER NAME	DESCRIPTION	ACCESS WIDTH	ACCESS TYPE	RESET VALUE
FFFE:D89A – FFFE:D8BE		Reserved			
FFFE:D8C0	SYS_DMA_CSDP_CH3	Channel 3 Source/Destination Parameters Register	16	RW	0000h
FFFE:D8C2	SYS_DMA_CCR_CH3	Channel 3 Control Register	16	RW	0000h
FFFE:D8C4	SYS_DMA_CICR_CH3	Channel 3 Interrupt Control Register	16	RW	0003h
FFFE:D8C6	SYS_DMA_CSR_CH3	Channel 3 Status Register	16	R	0000h
FFFE:D8C8	SYS_DMA_CSSA_L_CH3	Channel 3 Source Start Address Register LSB	16	RW	undef
FFFE:D8CA	SYS_DMA_CSSA_U_CH3	Channel 3 Source Start Address Register MSB	16	RW	undef
FFFE:D8CC	SYS_DMA_CDSA_L_CH3	Channel 3 Destination Start Address Register LSB	16	RW	undef
FFFE:D8CE	SYS_DMA_CDSA_U_CH3	Channel 3 Destination Start Address Register MSB	16	RW	undef
FFFE:D8D0	SYS_DMA_CEN_CH3	Channel 3 Element Number Register	16	RW	undef
FFFE:D8D2	SYS_DMA_CFN_CH3	Channel 3 Frame Number Register	16	RW	undef
FFFE:D8D4	SYS_DMA_CFI_CH3	Channel 3 Frame Index Register	16	RW	undef
FFFE:D8D6	SYS_DMA_CEI_CH3	Channel 3 Element Index Register	16	RW	undef
FFFE:D8D8	SYS_DMA_CPC_CH3	Channel 3 Progress Counter Register	16	RW	undef
FFFE:D8DA – FFFE:D8FE		Reserved			
FFFE:D900	SYS_DMA_CSDP_CH4	Channel 4 Source/Destination Parameters Register	16	RW	0000h
FFFE:D902	SYS_DMA_CCR_CH4	Channel 4 Control Register	16	RW	0000h
FFFE:D904	SYS_DMA_CICR_CH4	Channel 4 Interrupt Control Register	16	RW	0003h
FFFE:D906	SYS_DMA_CSR_CH4	Channel 4 Status Register	16	R	0000h
FFFE:D908	SYS_DMA_CSSA_L_CH4	Channel 4 Source Start Address Register LSB	16	RW	undef
FFFE:D90A	SYS_DMA_CSSA_U_CH4	Channel 4 Source Start Address Register MSB	16	RW	undef
FFFE:D90C	SYS_DMA_CDSA_L_CH4	Channel 4 Destination Start Address Register LSB	16	RW	undef
FFFE:D90E	SYS_DMA_CDSA_U_CH4	Channel 4 Destination Start Address Register MSB	16	RW	undef
FFFE:D910	SYS_DMA_CEN_CH4	Channel 4 Element Number Register	16	RW	undef
FFFE:D912	SYS_DMA_CFN_CH4	Channel 4 Frame Number Register	16	RW	undef
FFFE:D914	SYS_DMA_CFI_CH4	Channel 4 Frame Index Register	16	RW	undef
FFFE:D916	SYS_DMA_CEI_CH4	Channel 4 Element Index Register	16	RW	undef
FFFE:D918	SYS_DMA_CPC_CH4	Channel 4 Progress Counter Register	16	RW	undef
FFFE:D91A – FFFE:D93E		Reserved			
FFFE:D940	SYS_DMA_CSDP_CH5	Channel 5 Source/Destination Parameters Register	16	RW	0000h
FFFE:D942	SYS_DMA_CCR_CH5	Channel 5 Control Register	16	RW	0000h
FFFE:D944	SYS_DMA_CICR_CH5	Channel 5 Interrupt Control Register	16	RW	0003h
FFFE:D946	SYS_DMA_CSR_CH5	Channel 5 Status Register	16	R	0000h
FFFE:D948	SYS_DMA_CSSA_L_CH5	Channel 5 Source Start Address Register LSB	16	RW	undef
FFFE:D94A	SYS_DMA_CSSA_U_CH5	Channel 5 Source Start Address Register MSB	16	RW	undef
FFFE:D94C	SYS_DMA_CDSA_L_CH5	Channel 5 Destination Start Address Register LSB	16	RW	undef
FFFE:D94E	SYS_DMA_CDSA_U_CH5	Channel 5 Destination Start Address Register MSB	16	RW	undef
FFFE:D950	SYS_DMA_CEN_CH5	Channel 5 Element Number Register	16	RW	undef
FFFE:D952	SYS_DMA_CFN_CH5	Channel 5 Frame Number Register	16	RW	undef
FFFE:D954	SYS_DMA_CFI_CH5	Channel 5 Frame Index Register	16	RW	undef
FFFE:D956	SYS_DMA_CEI_CH5	Channel 5 Element Index Register	16	RW	undef

PRODUCT PREVIEW

Table 3–20. System DMA Controller Registers (Continued)

BYTE ADDRESS	REGISTER NAME	DESCRIPTION	ACCESS WIDTH	ACCESS TYPE	RESET VALUE
FFFE:D958	SYS_DMA_CPC_CH5	Channel 5 Progress Counter Register	16	RW	undef
FFFE:D95A – FFFE:D97E		Reserved			
FFFE:D980	SYS_DMA_CSDP_CH6	Channel 6 Source/Destination Parameters Register	16	RW	0000h
FFFE:D982	SYS_DMA_CCR_CH6	Channel 6 Control Register	16	RW	0000h
FFFE:D984	SYS_DMA_CICR_CH6	Channel 6 Interrupt Control Register	16	RW	0003h
FFFE:D986	SYS_DMA_CSR_CH6	Channel 6 Status Register	16	R	0000h
FFFE:D988	SYS_DMA_CSSA_L_CH6	Channel 6 Source Start Address Register LSB	16	RW	undef
FFFE:D98A	SYS_DMA_CSSA_U_CH6	Channel 6 Source Start Address Register MSB	16	RW	undef
FFFE:D98C	SYS_DMA_CDSA_L_CH6	Channel 6 Destination Start Address Register LSB	16	RW	undef
FFFE:D98E	SYS_DMA_CDSA_U_CH6	Channel 6 Destination Start Address Register MSB	16	RW	undef
FFFE:D990	SYS_DMA_CEN_CH6	Channel 6 Element Number Register	16	RW	undef
FFFE:D992	SYS_DMA_CFN_CH6	Channel 6 Frame Number Register	16	RW	undef
FFFE:D994	SYS_DMA_CFI_CH6	Channel 6 Frame Index Register	16	RW	undef
FFFE:D996	SYS_DMA_CEI_CH6	Channel 6 Element Index Register	16	RW	undef
FFFE:D998	SYS_DMA_CPC_CH6	Channel 6 Progress Counter Register	16	RW	undef
FFFE:D99A – FFFE:D9BE		Reserved			
FFFE:D9C0	SYS_DMA_CSDP_CH7	Channel 7 Source/Destination Parameters Register	16	RW	0000h
FFFE:D9C2	SYS_DMA_CCR_CH7	Channel 7 Control Register	16	RW	0000h
FFFE:D9C4	SYS_DMA_CICR_CH7	Channel 7 Interrupt Control Register	16	RW	0003h
FFFE:D9C6	SYS_DMA_CSR_CH7	Channel 7 Status Register	16	R	0000h
FFFE:D9C8	SYS_DMA_CSSA_L_CH7	Channel 7 Source Start Address Register LSB	16	RW	undef
FFFE:D9CA	SYS_DMA_CSSA_U_CH7	Channel 7 Source Start Address Register MSB	16	RW	undef
FFFE:D9CC	SYS_DMA_CDSA_L_CH7	Channel 7 Destination Start Address Register LSB	16	RW	undef
FFFE:D9CE	SYS_DMA_CDSA_U_CH7	Channel 7 Destination Start Address Register MSB	16	RW	undef
FFFE:D9D0	SYS_DMA_CEN_CH7	Channel 7 Element Number Register	16	RW	undef
FFFE:D9D2	SYS_DMA_CFN_CH7	Channel 7 Frame Number Register	16	RW	undef
FFFE:D9D4	SYS_DMA_CFI_CH7	Channel 7 Frame Index Register	16	RW	undef
FFFE:D9D6	SYS_DMA_CEI_CH7	Channel 7 Element Index Register	16	RW	undef
FFFE:D9D8	SYS_DMA_CPC_CH7	Channel 7 Progress Counter Register	16	RW	undef
FFFE:D9DA – FFFE:D9FE		Reserved			
FFFE:DA00	SYS_DMA_CSDP_CH8	Channel 8 Source/Destination Parameters Register	16	RW	0000h
FFFE:DA02	SYS_DMA_CCR_CH8	Channel 8 Control Register	16	RW	0000h
FFFE:DA04	SYS_DMA_CICR_CH8	Channel 8 Interrupt Control Register	16	RW	0003h
FFFE:DA06	SYS_DMA_CSR_CH8	Channel 8 Status Register	16	R	0000h
FFFE:DA08	SYS_DMA_CSSA_L_CH8	Channel 8 Source Start Address Register LSB	16	RW	undef
FFFE:DA0A	SYS_DMA_CSSA_U_CH8	Channel 8 Source Start Address Register MSB	16	RW	undef
FFFE:DA0C	SYS_DMA_CDSA_L_CH8	Channel 8 Destination Start Address Register LSB	16	RW	undef
FFFE:DA0E	SYS_DMA_CDSA_U_CH8	Channel 8 Destination Start Address Register MSB	16	RW	undef
FFFE:DA10	SYS_DMA_CEN_CH8	Channel 8 Element Number Register	16	RW	undef
FFFE:DA12	SYS_DMA_CFN_CH8	Channel 8 Frame Number Register	16	RW	undef
FFFE:DA14	SYS_DMA_CFI_CH8	Channel 8 Frame Index Register	16	RW	undef

Table 3–20. System DMA Controller Registers (Continued)

BYTE ADDRESS	REGISTER NAME	DESCRIPTION	ACCESS WIDTH	ACCESS TYPE	RESET VALUE
FFFE:DA16	SYS_DMA_CEI_CH8	Channel 8 Element Index Register	16	RW	undef
FFFE:DA18	SYS_DMA_CPC_CH8	Channel 8 Progress Counter Register	16	RW	undef
FFFE:DA1A – FFFE:DAFE		Reserved			
FFFE:DB00	SYS_DMA_LCD_CTRL	LCD Chan. Control Register	16	RW	0000h
FFFE:DB02	SYS_DMA_LCD_TOP_F1_L	LCD Chan. Top Address Frame Buffer 1 Register LSB	16	RW	undef
FFFE:DB04	SYS_DMA_LCD_TOP_F1_U	LCD Chan. Top Address Frame Buffer 1 Register MSB	16	RW	undef
FFFE:DB06	SYS_DMA_LCD_BOT_F1_L	LCD Chan. Bottom Address Frame Buffer 1 Register LSB	16	RW	undef
FFFE:DB08	SYS_DMA_LCD_BOT_F1_U	LCD Chan. Bottom Address Frame Buffer 1 Register MSB	16	RW	undef
FFFE:DB0A	SYS_DMA_LCD_TOP_F2_L	LCD Chan. Top Address Frame Buffer 2 Register LSB	16	RW	undef
FFFE:DB0C	SYS_DMA_LCD_TOP_F2_U	LCD Chan. Top Address Frame Buffer 2 Register MSB	16	RW	undef
FFFE:DB0E	SYS_DMA_LCD_BOT_F2_L	LCD Chan. Bottom Address Frame Buffer 2 Register LSB	16	RW	undef
FFFE:DB10	SYS_DMA_LCD_BOT_F2_U	LCD Chan. Bottom Address Frame Buffer 2 Register MSB	16	RW	undef
FFFE:DB12 – FFFE:DBFE		Reserved			
FFFE:DC00	SYS_DMA_GCR	DMA Global Control Register	16	RW	0008h

Table 3–21. LCD Controller Registers

BYTE ADDRESS	REGISTER NAME	DESCRIPTION	ACCESS WIDTH	ACCESS TYPE	RESET VALUE
FFFE:C000	LCD_CONTROL	LCD Control Register	32	RW	0x0000 0000
FFFE:C004	LCD_TIMING0	LCD Timing 0 Register	32	RW	undef
FFFE:C008	LCD_TIMING1	LCD Timing 1 Register	32	RW	0x0000 0000
FFFE:C00C	LCD_TIMING2	LCD Timing 2 Register	32	RW	0x0000 0000
FFFE:C010	LCD_STATUS	LCD Status Register	32	RW	0x0000 0000
FFFE:C014	LCD_SUBPANEL	LCD Subpanel Display Register	32	RW	0x0000 0000

PRODUCT PREVIEW

3.15.2 MPU Public Peripheral Registers

The MPU public peripheral registers include the following:

- Serial Ports
 - McBSP2 Registers
 - Microwire Registers
 - I²C Registers
 - HDQ/1-Wire Interface Registers
 - MMC/SD Registers
 - USB Function Registers
 - USB Host Registers
- Parallel Ports
 - Camera Interface Registers
- Human Interface support
 - MPUIO/Keyboard Registers
 - PWL Registers
 - PWT Registers
 - LED Pulse Generator 1 Registers
 - LED Pulse Generator 2 Registers
- Timers and Counters
 - 32k Timer Registers
 - Real-Time Clock Registers
 - Frame Adjustment Counter Registers

Table 3–22. McBSP2 Registers

BYTE ADDRESS	REGISTER NAME	DESCRIPTION	ACCESS WIDTH	ACCESS TYPE	RESET VALUE
FFFB:1000	MCBSP2_DRR2	McBSP2 Data receive register 2	16	RW	0000h
FFFB:1002	MCBSP2_DRR1	McBSP2 Data receive register 1	16	RW	0000h
FFFB:1004	MCBSP2_DXR2	McBSP2 Data transmit register 2	16	RW	0000h
FFFB:1006	MCBSP2_DXR1	McBSP2 Data transmit register 1	16	RW	0000h
FFFB:1008	MCBSP2_SPCR2	McBSP2 Serial port control register 2	16	RW	0000h
FFFB:100A	MCBSP2_SPCR1	McBSP2 Serial port control register 1	16	RW	0000h
FFFB:100C	MCBSP2_RCR2	McBSP2 Receive control register 2	16	RW	0000h
FFFB:100E	MCBSP2_RCR1	McBSP2 Receive control register 1	16	RW	0000h
FFFB:1010	MCBSP2_XCR2	McBSP2 Transmit control register 2	16	RW	0000h
FFFB:1012	MCBSP2_XCR1	McBSP2 Transmit control register 1	16	RW	0000h
FFFB:1014	MCBSP2_SRGR2	McBSP2 Sample rate generator register 2	16	RW	2000h
FFFB:1016	MCBSP2_SRGR1	McBSP2 Sample rate generator register 1	16	RW	0001h
FFFB:1018	MCBSP2_MCR2	McBSP2 Multichannel register 2	16	RW	0000h
FFFB:101A	MCBSP2_MCR1	McBSP2 Multichannel register 1	16	RW	0000h
FFFB:101C	MCBSP2_RCERA	McBSP2 Receive channel enable register partition A	16	RW	0000h
FFFB:101E	MCBSP2_RCERB	McBSP2 Receive channel enable register partition B	16	RW	0000h
FFFB:1020	MCBSP2_XCERA	McBSP2 Transmit channel enable register partition A	16	RW	0000h
FFFB:1022	MCBSP2_XCERB	McBSP2 Transmit channel enable register partition B	16	RW	0000h
FFFB:1024	MCBSP2_PCR0	McBSP2 Pin control register 0	16	RW	0000h
FFFB:1026	MCBSP2_RCERC	McBSP2 Receive channel enable register partition C	16	RW	0000h
FFFB:1028	MCBSP2_RCERD	McBSP2 Receive channel enable register partition D	16	RW	0000h
FFFB:102A	MCBSP2_XCERC	McBSP2 Transmit channel enable register partition C	16	RW	0000h
FFFB:102C	MCBSP2_XCERD	McBSP2 Transmit channel enable register partition D	16	RW	0000h
FFFB:102E	MCBSP2_RCERE	McBSP2 Receive channel enable register partition E	16	RW	0000h
FFFB:1030	MCBSP2_RCERF	McBSP2 Receive channel enable register partition F	16	RW	0000h
FFFB:1032	MCBSP2_XCERE	McBSP2 Transmit channel enable register partition E	16	RW	0000h
FFFB:1034	MCBSP2_XCERF	McBSP2 Transmit channel enable register partition F	16	RW	0000h
FFFB:1036	MCBSP2_RCERG	McBSP2 Receive channel enable register partition G	16	RW	0000h
FFFB:1038	MCBSP2_RCERH	McBSP2 Receive channel enable register partition H	16	RW	0000h
FFFB:103A	MCBSP2_XCERG	McBSP2 Transmit channel enable register partition G	16	RW	0000h
FFFB:103C	MCBSP2_XCERH	McBSP2 Transmit channel enable register partition H	16	RW	0000h

Table 3–23. Microwire Registers

BYTE ADDRESS	REGISTER NAME	DESCRIPTION	ACCESS WIDTH	ACCESS TYPE	RESET VALUE
FFFB:3000	TD	Microwire Transmit Data Register	16	W	undef
FFFB:3000	RD	Microwire Receive Data Register	16	R	undef
FFFB:3004	CSR	Microwire Control and Status Register	16	RW	undef
FFFB:3008	SR1	Microwire Setup Register 1	16	RW	undef
FFFB:300C	SR2	Microwire Setup Register 2	16	RW	undef
FFFB:3010	SR3	Microwire Setup Register 3	16	RW	0000h
FFFB:3014	SR4	Microwire Setup Register 4	16	RW	0000h
FFFB:3018	SR5	Microwire Setup Register 5	16	RW	0000h

PRODUCT PREVIEW

Table 3–24. I²C Registers

BYTE ADDRESS	REGISTER NAME	DESCRIPTION	ACCESS WIDTH	ACCESS TYPE	RESET VALUE
FFFB:3800	I2C_REV	I ² C Module Version Register	16	RW	0011h
FFFB:3804	I2C_IE	I ² C Interrupt Enable Register	16	RW	0000h
FFFB:3808	I2C_STAT	I ² C Status Register	16	R	0000h
FFFB:380C	I2C_IV	I ² C Interrupt Vector Register	16	R	0000h
FFFB:3810		Reserved			
FFFB:3814	I2C_BUF	I ² C Buffer Configuration Register	16	RW	0000h
FFFB:3818	I2C_CNT	I ² C Data Counter Register	16	RW	0000h
FFFB:381C	I2C_DATA	I ² C Data Access Register	16	RW	0000h
FFFB:3820		Reserved			
FFFB:3824	I2C_CON	I ² C Configuration Register	16	RW	0000h
FFFB:3828	I2C_OA	I ² C Own Address Register	16	RW	0000h
FFFB:382C	I2C_SA	I ² C Slave Address Register	16	RW	03FFh
FFFB:3830	I2C_PSC	I ² C Clock Prescaler Register	16	RW	0000h
FFFB:3834	I2C_SCLL	I ² C SCL Low Timer Register	16	RW	0000h
FFFB:3838	I2C_SCLH	I ² C SCL High Timer Register	16	RW	0000h
FFFB:383C	I2C_SYSTEST	I ² C System Test Register	16	RW	0000h

Table 3–25. HDQ/1-Wire Interface Registers

BYTE ADDRESS	REGISTER NAME	DESCRIPTION	ACCESS WIDTH	ACCESS TYPE	RESET VALUE
FFFB:C000	TXR	TX Write Data Register	8	RW	00h
FFFB:C004	RXR	RX Receive Buffer Register	8	R	undef
FFFB:C008	CSR	Control and Status Register	8	RW	00h
FFFB:C00C	ISR	Interrupt Status Register	8	RW	00h

Table 3–26. MMC/SD Registers

BYTE ADDRESS	REGISTER NAME	DESCRIPTION	ACCESS WIDTH	ACCESS TYPE	RESET VALUE
FFFB:7800	MMC_CMD	MMC command	16	RW	0000h
FFFB:7804	MMC_ARGL	MMC argument low	16	RW	0000h
FFFB:7808	MMC_ARGH	MMC argument high	16	RW	0000h
FFFB:780C	MMC_CON	MMC system configuration	16	RW	0000h
FFFB:7810	MMC_STAT	MMC status	16	RW	0000h
FFFB:7814	MMC_IE	MMC system interrupt enable	16	RW	0000h
FFFB:7818	MMC_CTO	MMC command timeout	16	RW	0000h
FFFB:781C	MMC_DTO	MMC data timeout	16	RW	0000h
FFFB:7820	MMC_DATA	MMC TX/RX FIFO data	16	RW	0000h
FFFB:7824	MMC_BLEN	MMC block length	16	RW	0000h
FFFB:7828	MMC_NBLK	MMC number of blocks	16	RW	0000h
FFFB:782C	MMC_BUF	MMC buffer configuration	16	RW	1F00h
FFFB:7830	MMC_SPI	MMC serial port interface	16	RW	0000h
FFFB:7834	MMC_SDIO	MMC SDIO mode configuration	16	RW	0000h
FFFB:7838	MMC_SYST	MMC system test	16	RW	2000h
FFFB:783C	MMC_REV	MMC module version	16	R	–
FFFB:7840	MMC_RSP0	MMC command response 0	16	R	undef
FFFB:7844	MMC_RSP1	MMC command response 1	16	R	undef
FFFB:7848	MMC_RSP2	MMC command response 2	16	R	undef
FFFB:784C	MMC_RSP3	MMC command response 3	16	R	undef
FFFB:7850	MMC_RSP4	MMC command response 4	16	R	undef
FFFB:7854	MMC_RSP5	MMC command response 5	16	R	undef
FFFB:7858	MMC_RSP6	MMC command response 6	16	R	undef
FFFB:785C	MMC_RSP7	MMC command response 7	16	R	undef

PRODUCT PREVIEW

Table 3–27. USB Function Registers

BYTE ADDRESS	REGISTER NAME	DESCRIPTION	ACCESS WIDTH	ACCESS TYPE	RESET VALUE
FFFB:4000	REV	Revision Register	16	R	–
FFFB:4004	EP_NUM	Endpoint Selection Register	16	RW	0000h
FFFB:4008	DATA	Data Register	16	RW	undef
FFFB:400C	CTRL	Control Register	16	RW	0000h
FFFB:4010	STAT_FLG	Status Flag Register	16	R	0202h
FFFB:4014	RXFSTAT	Receive FIFO Status Register	16	R	0000h
FFFB:4018	SYSCON1	System Configuration 1 Register	16	RW	0000h
FFFB:401C	SYSCON2	System Configuration 2 Register	16	RW	0000h
FFFB:4020	DEVSTAT	Device Status Register	16	R	undef
FFFB:4024	SOF	Start of Frame Register	16	R	0000h
FFFB:4028	IRQ_EN	Interrupt Enable Register	16	RW	undef
FFFB:402C	DMA_IRQ_EN	DMA Interrupt Enable Register	16	RW	undef
FFFB:4030	IRQ_SRC	Interrupt Source Register	16	RW	0000h
FFFB:4034	EPN_STAT	Endpoint Interrupt Status Register	16	R	0000h
FFFB:4038	DMAN_STAT	DMA Endpoint Interrupt Status Register	16	R	0000h
FFFB:403C		Reserved			
FFFB:4040	RXDMA_CFG	Receive Channels DMA Configuration Register	16	RW	0000h
FFFB:4044	TXDMA_CFG	Transmit Channels DMA Configuration Register	16	RW	0000h
FFFB:4048	DATA_DMA	DMA FIFO Data Register	16	RW	undef
FFFB:404C		Reserved			
FFFB:4050	TXDMA0	Transmit DMA Control 0 Register	16	RW	0000h
FFFB:4054	TXDMA1	Transmit DMA Control 1 Register	16	RW	0000h
FFFB:4058	TXDMA2	Transmit DMA Control 2 Register	16	RW	0000h
FFFB:405C		Reserved			
FFFB:4060	RXDMA0	Receive DMA Control 0 Register	16	RW	0000h
FFFB:4064	RXDMA1	Receive DMA Control 1 Register	16	RW	0000h
FFFB:4068	RXDMA2	Receive DMA Control 2 Register	16	RW	0000h
FFFB:406C – FFFB:407C		Reserved			
FFFB:4080	EP0	Endpoint Configuration 0 Register	16	RW	0000h
FFFB:4084	EP1_RX	Receive Endpoint Configuration 1 Register	16	RW	undef
FFFB:4088	EP2_RX	Receive Endpoint Configuration 2 Register	16	RW	undef
FFFB:408C	EP3_RX	Receive Endpoint Configuration 3 Register	16	RW	undef
FFFB:4090	EP4_RX	Receive Endpoint Configuration 4 Register	16	RW	undef
FFFB:4094	EP5_RX	Receive Endpoint Configuration 5 Register	16	RW	undef
FFFB:4098	EP6_RX	Receive Endpoint Configuration 6 Register	16	RW	undef
FFFB:409C	EP7_RX	Receive Endpoint Configuration 7 Register	16	RW	undef
FFFB:40A0	EP8_RX	Receive Endpoint Configuration 8 Register	16	RW	undef
FFFB:40A4	EP9_RX	Receive Endpoint Configuration 9 Register	16	RW	undef
FFFB:40A8	EP10_RX	Receive Endpoint Configuration 10 Register	16	RW	undef
FFFB:40AC	EP11_RX	Receive Endpoint Configuration 11 Register	16	RW	undef
FFFB:40B0	EP12_RX	Receive Endpoint Configuration 12 Register	16	RW	undef
FFFB:40B4	EP13_RX	Receive Endpoint Configuration 13 Register	16	RW	undef
FFFB:40B8	EP14_RX	Receive Endpoint Configuration 14 Register	16	RW	undef

Table 3–27. USB Function Registers (Continued)

BYTE ADDRESS	REGISTER NAME	DESCRIPTION	ACCESS WIDTH	ACCESS TYPE	RESET VALUE
FFFB:40BC	EP15_RX	Receive Endpoint Configuration 15 Register	16	RW	undef
FFFB:40C0		Reserved			
FFFB:40C4	EP1_TX	Transmit Endpoint Configuration 1 Register	16	RW	undef
FFFB:40C8	EP2_TX	Transmit Endpoint Configuration 2 Register	16	RW	undef
FFFB:40CC	EP3_TX	Transmit Endpoint Configuration 3 Register	16	RW	undef
FFFB:40D0	EP4_TX	Transmit Endpoint Configuration 4 Register	16	RW	undef
FFFB:40D4	EP5_TX	Transmit Endpoint Configuration 5 Register	16	RW	undef
FFFB:40D8	EP6_TX	Transmit Endpoint Configuration 6 Register	16	RW	undef
FFFB:40DC	EP7_TX	Transmit Endpoint Configuration 7 Register	16	RW	undef
FFFB:40E0	EP8_TX	Transmit Endpoint Configuration 8 Register	16	RW	undef
FFFB:40E4	EP9_TX	Transmit Endpoint Configuration 9 Register	16	RW	undef
FFFB:40E8	EP10_TX	Transmit Endpoint Configuration 10 Register	16	RW	undef
FFFB:40EC	EP11_TX	Transmit Endpoint Configuration 11 Register	16	RW	undef
FFFB:40F0	EP12_TX	Transmit Endpoint Configuration 12 Register	16	RW	undef
FFFB:40F4	EP13_TX	Transmit Endpoint Configuration 13 Register	16	RW	undef
FFFB:40F8	EP14_TX	Transmit Endpoint Configuration 14 Register	16	RW	undef
FFFB:40FC	EP15_TX	Transmit Endpoint Configuration 15 Register	16	RW	undef

PRODUCT PREVIEW

Table 3–28. USB Host Controller Registers

BYTE ADDRESS	REGISTER NAME	DESCRIPTION	ACCESS WIDTH	ACCESS TYPE	RESET VALUE
FFFB:A000	HcRevision	OHCI Revision Register	32	R	0000 0010h
FFFB:A004	HcControl	Host Controller Operating Mode Register	32	RW	0000 0000h
FFFB:A008	HcCommandStatus	Host Controller Command and Status Register	32	RW	0000 0000h
FFFB:A00C	HcInterruptStatus	Host Controller Interrupt Status Register	32	RW	0000 0000h
FFFB:A010	HcInterruptEnable	Host Controller Interrupt Enable Register	32	RW	0000 0000h
FFFB:A014	HcInterruptDisable	Host Controller Interrupt Disable Register	32	R	0000 0000h
FFFB:A018	HcHCCA	LB Virtual Address HCCA Register	32	RW	0000 0000h
FFFB:A01C	HcPeriodCurrentED	LB Virtual Address Current Periodic EP Descriptor Register	32	RW	0000 0000h
FFFB:A020	HcControlHeadED	LB Virtual Address Control EP Descriptor List Head Register	32	RW	0000 0000h
FFFB:A024	HcControlCurrentED	LB Virtual Address Current Control EP Descriptor Register	32	RW	0000 0000h
FFFB:A028	HcBulkHeadED	LB Virtual Address Bulk EP Descriptor List Head Register	32	RW	0000 0000h
FFFB:A02C	HcBulkCurrentED	LB Virtual Address Current Bulk EP Descriptor Register	32	RW	0000 0000h
FFFB:A030	HcDoneHead	LB Virtual Address Retired Transfer Descriptor List Head Register	32	R	undef
FFFB:A034	HcFmInterval	Frame Interval Register	32	RW	0000 2EDFh
FFFB:A038	HcFmRemaining	Remaining Frame Time Register	32	R	0000 0000h
FFFB:A03C	HcFmNumber	Remaining Frame Number Register	32	R	0000 0000h
FFFB:A040	HcPeriodicStart	Periodic Start Time Register	32	RW	0000 0000h
FFFB:A044	HcLSThreshold	Low Speed Start Threshold Register	32	RW	0000 0628h
FFFB:A048	HcRhDescriptorA	USB Root Hub Descriptor Register A	32	RW	0A00 1203h
FFFB:A04C	HcRhDescriptorB	USB Root Hub Descriptor Register B	32	RW	0000 0000h
FFFB:A050	HcRhStatus	USB Root Hub Status Register	32	RW	0000 0000h
FFFB:A054	HcRhPortStatus1	Port 1 Control and Status Register	32	RW	0000 0100h
FFFB:A058	HcRhPortStatus2	Port 2 Control and Status Register	32	RW	0000 0100h
FFFB:A05C	HcRhPortStatus3	Port 3 Control and Status Register	32	RW	0000 0100h
FFFB:A060 – FFFB:A0DC		Reserved			
FFFB:A0E0	HostUEAddr	LB Virtual Address Last Unrecoverable Error Register	32	R	0000 0000h
FFFB:A0E4	HostUEStatus	LB Cycle Type Last Unrecoverable Error Register	32	R	0000 0000h
FFFB:A0E8	HostTimeoutCtrl	USB Host Mastered Local Bus Time-out Enable Register	32	RW	0000 0000h
FFFB:A0EC	HostRevision	USB Host Controller Revision Register	32	R	–

Table 3–29. Camera Interface Registers

BYTE ADDRESS	REGISTER NAME	DESCRIPTION	ACCESS WIDTH	ACCESS TYPE	RESET VALUE
FFFB:6800	CTRLCLOCK	Clock Control Register	32	RW	0000 0000h
FFFB:6804	IT_STATUS	Interrupt Status Register	32	R	0000 0000h
FFFB:6808	MODE	Mode Configuration Register	32	RW	0000 0200h
FFFB:680C	STATUS	Status Register	32	R	0000 0000h
FFFB:6810	CAMDATA	Image Data Register	32	R	0000 0000h
FFFB:6814	GPIO	GPIO Register	32	RW	0000 0000h
FFFB:6818	PEAK_COUNTER	Fifo Peak Counter Register	32	RW	0000 0000h

Table 3–30. MPU I/O/Keyboard Registers

BYTE ADDRESS	REGISTER NAME	DESCRIPTION	ACCESS WIDTH	ACCESS TYPE	RESET VALUE
FFFB:5000	INPUT_LATCH	Input Register	16	R	undef
FFFB:5004	OUTPUT_REG	Output Register	16	RW	undef
FFFB:5008	IO_CNTL	Input Output Control Register	16	RW	FFFFh
FFFB:500C		Reserved			
FFFB:5010	KBR_LATCH	Keyboard Row Inputs Register	16	R	undef
FFFB:5014	KBC_REG	Keyboard Column Outputs Register	16	RW	0000h
FFFB:5018	GPIO_EVENT_MODE	GPIO Event Mode Register	16	RW	0000h
FFFB:501C	GPIO_INT_EDGE	GPIO Interrupt Edge Register	16	RW	0000h
FFFB:5020	KBD_INT	Keyboard Interrupt Register	16	R	0000h
FFFB:5024	GPIO_INT	GPIO Interrupt Register	16	R	0000h
FFFB:5028	KBD_MASKIT	Keyboard Mask Interrupt Register	16	RW	0000h
FFFB:502C	GPIO_MASKIT	GPIO Mask Interrupt Register	16	RW	0000h
FFFB:5030	GPIO_DEBOUNCING	GPIO Debouncing Register	16	RW	0000h
FFFB:5034	GPIO_LATCH	GPIO Latch Register	16	R	0000h

Table 3–31. PWL Registers

BYTE ADDRESS	REGISTER NAME	DESCRIPTION	ACCESS WIDTH	ACCESS TYPE	RESET VALUE
FFFB:5800	PWL_LEVEL	PWL Level Register	8	RW	0000h
FFFB:5804	PWL_CTRL	PWL Control Register	8	RW	0000h

Table 3–32. PWT Registers

BYTE ADDRESS	REGISTER NAME	DESCRIPTION	ACCESS WIDTH	ACCESS TYPE	RESET VALUE
FFFB:6000	PWT_FRC	PWT Frequency Control Register	8	RW	0000h
FFFB:6004	PWT_VCR	PWT Volume Control Register	8	RW	0000h
FFFB:6008	PWT_GCR	PWT General Control Register	8	RW	0000h

Table 3–33. LED Pulse Generator 1 Registers

BYTE ADDRESS	REGISTER NAME	DESCRIPTION	ACCESS WIDTH	ACCESS TYPE	RESET VALUE
FFFB:D000	LCR_1	LPG1 Control Register	8	RW	00h
FFFB:D004	PMR_1	LPG1 Power Management Register	8	RW	00h

Table 3–34. LED Pulse Generator 2 Registers

BYTE ADDRESS	REGISTER NAME	DESCRIPTION	ACCESS WIDTH	ACCESS TYPE	RESET VALUE
FFFB:D800	LCR_2	LPG2 Control Register	8	RW	00h
FFFB:D804	PMR_2	LPG2 Power Management Register	8	RW	00h

Table 3–35. 32k Timer Registers

BYTE ADDRESS	REGISTER NAME	DESCRIPTION	ACCESS WIDTH	ACCESS TYPE	RESET VALUE
FFFB:9000	TVR	Tick Value Register	32	RW	00FF FFFFh
FFFB:9004	TCR	Tick Counter Register	32	R	00FF FFFFh
FFFB:9008	CR	Control Register	32	RW	0000 0008h

Table 3–36. Real-Time Clock Registers

BYTE ADDRESS	REGISTER NAME	DESCRIPTION	ACCESS WIDTH	ACCESS TYPE	RESET VALUE
FFFB:4800	SECONDS_REG	RTC Seconds Register	8	RW	00h
FFFB:4804	MINUTES_REG	RTC Minutes Register	8	RW	00h
FFFB:4808	HOURS_REG	RTC Hours Register	8	RW	00h
FFFB:480C	DAYS_REG	RTC Days Register	8	RW	01h
FFFB:4810	MONTHS_REG	RTC Months Register	8	RW	01h
FFFB:4814	YEARS_REG	RTC Years Register	8	RW	00h
FFFB:4818	WEEK_REG	RTC Weeks Register	8	RW	00h
FFFB:481C		Reserved			
FFFB:4820	ALARM_SECONDS_REG	RTC Alarm Seconds Register	8	RW	00h
FFFB:4824	ALARM_MINUTES_REG	RTC Alarm Minutes Register	8	RW	00h
FFFB:4828	ALARM_HOURS_REG	RTC Alarm Hours Register	8	RW	00h
FFFB:482C	ALARM_DAYS_REG	RTC Alarm Days Register	8	RW	01h
FFFB:4830	ALARM_MONTHS_REG	RTC Alarm Months Register	8	RW	01h
FFFB:4834	ALARM_YEARS_REG	RTC Alarm Years Register	8	RW	00h
FFFB:4838 – FFFB:483C		Reserved			
FFFB:4840	RTC_CTRL_REG	RTC Control Register	8	RW	00h
FFFB:4844	RTC_STATUS_REG	RTC Status Register	8	RW	00h
FFFB:4848	RTC_INTERRUPTS_REG	RTC Interrupts Register	8	RW	00h
FFFB:484C	RTC_COMP_LSB_REG	RTC Compensation LSB Register	8	RW	00h
FFFB:4850	RTC_COMP_MSB_REG	RTC Compensation MSB Register	8	RW	00h

Table 3–37. Frame Adjustment Counter Registers

BYTE ADDRESS	REGISTER NAME	DESCRIPTION	ACCESS WIDTH	ACCESS TYPE	RESET VALUE
FFFB:A800	FARC	Frame Adjustment Reference Count Register	16	RW	0000h
FFFB:A804	FSC	Frame Start Count Register	16	R	0000h
FFFB:A808	CTRL	Control and Configuration Register	16	RW	0000h
FFFB:A80C	STATUS	Status Register	16	R	0000h
FFFB:A810	SYNC_CNT	Frame Synchronization Register	16	R	undef
FFFB:A814	START_CNT	Frame Start Counter Register	16	R	undef

3.15.3 MPU Configuration Registers

The MPU Configuration Registers include the following:

- Pin Multiplexing setup:
 - OMAP5910 Pin Configuration Registers
- Local Bus and MMU setup:
 - Local Bus Control Registers
 - Local Bus MMU Registers
 - DSP MMU Registers
- MPUI and TIPB setup:
 - MPU Interface (MPUI) Registers
 - TIPB (Private) Bridge 1 Configuration Registers
 - TIPB (Public) Bridge 2 Configuration Registers
 - MPU UART TI Peripheral Bus Switch Registers
 - Traffic Controller Registers
- Clock and Power Management:
 - MPU Clock/Reset/Power Mode Control Registers
 - DPLL1 Configuration Register
 - Ultra Low-Power Device Module Registers
- Device Identification:
 - Device Die Identification Registers
 - JTAG Identification Code Register

Table 3–38. OMAP 5910 Pin Configuration Registers

BYTE ADDRESS	REGISTER NAME	DESCRIPTION	ACCESS WIDTH	ACCESS TYPE	RESET VALUE
FFFE:1000	FUNC_MUX_CTRL_0	Functional Multiplexing Control 0 Register	32	RW	0000 0000h
FFFE:1004	FUNC_MUX_CTRL_1	Functional Multiplexing Control 1 Register	32	RW	0000 0000h
FFFE:1008	FUNC_MUX_CTRL_2	Functional Multiplexing Control 2 Register	32	RW	0000 0000h
FFFE:100C	COMP_MODE_CTRL_0	Compatibility Mode Control 0 Register	32	RW	0000 0000h
FFFE:1010	FUNC_MUX_CTRL_3	Functional Multiplexing Control 3 Register	32	RW	0000 0000h
FFFE:1014	FUNC_MUX_CTRL_4	Functional Multiplexing Control 4 Register	32	RW	0000 0000h
FFFE:1018	FUNC_MUX_CTRL_5	Functional Multiplexing Control 5 Register	32	RW	0000 0000h
FFFE:101C	FUNC_MUX_CTRL_6	Functional Multiplexing Control 6 Register	32	RW	0000 0000h
FFFE:1020	FUNC_MUX_CTRL_7	Functional Multiplexing Control 7 Register	32	RW	0000 0000h
FFFE:1024	FUNC_MUX_CTRL_8	Functional Multiplexing Control 8 Register	32	RW	0000 0000h
FFFE:1028	FUNC_MUX_CTRL_9	Functional Multiplexing Control 9 Register	32	RW	0000 0000h
FFFE:102C	FUNC_MUX_CTRL_A	Functional Multiplexing Control A Register	32	RW	0000 0000h
FFFE:1030	FUNC_MUX_CTRL_B	Functional Multiplexing Control B Register	32	RW	0000 0000h
FFFE:1034	FUNC_MUX_CTRL_C	Functional Multiplexing Control C Register	32	RW	0000 0000h
FFFE:1038	FUNC_MUX_CTRL_D	Functional Multiplexing Control D Register	32	RW	0000 0000h
FFFE:103C		Reserved			
FFFE:1040	PULL_DWN_CTRL_0	Pulldown Control 0 Register	32	RW	0000 0000h
FFFE:1044	PULL_DWN_CTRL_1	Pulldown Control 1 Register	32	RW	0000 0000h
FFFE:1048	PULL_DWN_CTRL_2	Pulldown Control 2 Register	32	RW	0000 0000h
FFFE:104C	PULL_DWN_CTRL_3	Pulldown Control 3 Register	32	RW	0000 0000h
FFFE:1050	GATE_INH_CTRL_0	Gate and Inhibit Control 0 Register	32	RW	0000 0000h
FFFE:1054 – FFFE:105C		Reserved			
FFFE:1060	VOLTAGE_CTRL_0	Voltage Control 0 Register	32	RW	0000 0000h
FFFE:1064 – FFFE:106C		Reserved			
FFFE:1070	TEST_DBG_CTRL_0	Test Debug Control 0 Register	32	RW	0000 0000h
FFFE:1074 – FFFE:107C		Reserved			
FFFE:1080	MOD_CONF_CTRL_0	Module Configuration Control 0 Register	32	RW	0000 0000h

Table 3–39. Local Bus Control Registers

BYTE ADDRESS	REGISTER NAME	DESCRIPTION	ACCESS WIDTH	ACCESS TYPE	RESET VALUE
FFFE:C100	LB_MPU_TIMEOUT	Local bus MPU access TIMEOUT	32	RW	0000 00FFh
FFFE:C104	LB_HOLD_TIMER	Local bus hold timer	32	RW	0000 0000h
FFFE:C108	LB_PRIORITY_REG	Local bus MPU access priority	32	RW	0000 0000h
FFFE:C10C	LB_CLOCK_DIV	Local bus clock divider	32	RW	0000 00FCh
FFFE:C110	LB_ABORT_ADD	Local bus address of aborted MPU cycle	32	R	FFFF FFFFh
FFFE:C114	LB_ABORT_DATA	Local bus cycle data of aborted MPU write cycle	32	R	FFFF FFFFh
FFFE:C118	LB_ABORT_STATUS	Local bus cycle type of aborted MPU write cycle	32	R	0000 0000h
FFFE:C11C	LB_IRQ_OUTPUT	Local bus external interrupt output control	32	RW	0000 0000h
FFFE:C120	LB_IRQ_INPUT	Local bus external interrupt status	32	RW	0000 0000h

Table 3–40. Local Bus MMU Registers

BYTE ADDRESS	REGISTER NAME	DESCRIPTION	ACCESS WIDTH	ACCESS TYPE	RESET VALUE
FFFE:C204	LB_MMU_WALKING_ST_REG	Local bus MMU Walking Status	32	RW†	0000h
FFFE:C208	LB_MMU_CNTL_REG	Local bus MMU Control	32	RW†	0000h
FFFE:C20C	LB_MMU_FAULT_AD_H_REG	Local bus MMU Fault Address High	32	R	0000h
FFFE:C210	LB_MMU_FAULT_AD_L_REG	Local bus MMU Fault Address Low	32	R	0000h
FFFE:C214	LB_MMU_FAULT_ST_REG	Local bus MMU Fault Status	32	R	0000h
FFFE:C218	LB_MMU_IT_ACK_REG	Local bus MMU Interrupt Acknowledge	32	W	0000h
FFFE:C21C	LB_MMU_TTB_H_REG	Local bus MMU TTB Register High	32	RW†	0000h
FFFE:C220	LB_MMU_TTB_L_REG	Local bus MMU TTB Register Low	32	RW†	0000h
FFFE:C224	LB_MMU_LOCK_REG	Local bus MMU Lock Counter	32	RW	0000h
FFFE:C228	LB_MMU_LD_TLB_REG	Local bus MMU TLB Load/Read Control	32	RW	0000h
FFFE:C22C	LB_MMU_CAM_H_REG	Local bus MMU CAM Entry High	32	RW	0000h
FFFE:C230	LB_MMU_CAM_L_REG	Local bus MMU CAM Entry Low	32	RW	0000h
FFFE:C234	LB_MMU_RAM_H_REG	Local bus MMU RAM Entry High	32	RW	0000h
FFFE:C238	LB_MMU_RAM_L_REG	Local bus MMU RAM Entry Low	32	RW	0000h
FFFE:C23C	LB_MMU_GFLUSH_REG	Local bus MMU Global Flush Control	32	RW	0000h
FFFE:C240	LB_MMU_FLUSH_ENTRY_REG	Local bus MMU Individual Entry Flush Control	32	RW	0000h
FFFE:C244	LB_MMU_READ_CAM_H_REG	Local bus MMU CAM Read High	32	RW	0000h
FFFE:C248	LB_MMU_READ_CAM_L_REG	Local bus MMU CAM Read Low	32	RW	0000h
FFFE:C24C	LB_MMU_READ_RAM_H_REG	Local bus MMU RAM Read High	32	RW	0000h
FFFE:C250	LB_MMU_READ_RAM_L_REG	Local bus MMU RAM Read Low	32	RW	0000h

† Write access in ARM supervisor mode only.

PRODUCT PREVIEW

Table 3–41. DSP MMU Registers

BYTE ADDRESS	REGISTER NAME	DESCRIPTION	ACCESS WIDTH	ACCESS TYPE	RESET VALUE
FFFE:D200	DSP_MMU_PREFETCH_REG	DSP MMU Prefetch Register	32	RW	0000h
FFFE:D204	DSP_MMU_WALKING_ST_REG	DSP MMU Prefetch Status Register	32	R	0000h
FFFE:D208	DSP_MMU_CNTL_REG	DSP MMU Control Register	32	RW	0000h
FFFE:D20C	DSP_MMU_FAULT_AD_H_REG	DSP MMU Fault Address Register MSB	32	R	0000h
FFFE:D210	DSP_MMU_FAULT_AD_L_REG	DSP MMU Fault Address Register LSB	32	R	0000h
FFFE:D214	DSP_MMU_F_ST_REG	DSP MMU Fault Status Register	32	R	0000h
FFFE:D218	DSP_MMU_IT_ACK_REG	DSP MMU IT Acknowledge Register	32	W	0000h
FFFE:D21C	DSP_MMU_TTB_H_REG	DSP MMU TTB Register MSB	32	RW	0000h
FFFE:D220	DSP_MMU_TTB_L_REG	DSP MMU TTB Register LSB	32	RW	0000h
FFFE:D224	DSP_MMU_LOCK_REG	DSP MMU Lock Counter Register	32	RW	0000h
FFFE:D228	DSP_MMU_LD_TLB_REG	DSP MMU Load Entry TLB Register	32	RW	0000h
FFFE:D22C	DSP_MMU_CAM_H_REG	DSP MMU CAM Entry Register MSB	32	RW	0000h
FFFE:D230	DSP_MMU_CAM_L_REG	DSP MMU CAM Entry Register LSB	32	RW	0000h
FFFE:D234	DSP_MMU_RAM_H_REG	DSP MMU RAM Entry Register MSB	32	RW	0000h
FFFE:D238	DSP_MMU_RAM_L_REG	DSP MMU RAM Entry Register LSB	32	RW	0000h
FFFE:D23C	DSP_MMU_GFLUSH_REG	DSP MMU Global Flush Register	32	RW	0000h
FFFE:D240	DSP_MMU_FLUSH_ENTRY_REG	DSP MMU Individual Flush Register	32	RW	0000h
FFFE:D244	DSP_MMU_READ_CAM_H_REG	DSP MMU Read CAM Register MSB	32	RW	0000h
FFFE:D248	DSP_MMU_READ_CAM_L_REG	DSP MMU Read CAM Register LSB	32	RW	0000h
FFFE:D24C	DSP_MMU_READ_RAM_H_REG	DSP MMU Read RAM Register MSB	32	RW	0000h
FFFE:D250	DSP_MMU_READ_RAM_L_REG	DSP MMU Read RAM Register LSB	32	RW	0000h

Table 3–42. MPUI Registers

BYTE ADDRESS	REGISTER NAME	DESCRIPTION	ACCESS WIDTH	ACCESS TYPE	RESET VALUE
FFFE:C900	CTRL_REG	MPUI Control Register	32	RW	0003 FF1Bh
FFFE:C904	DEBUG_ADDR	MPUI Debug Address Register	32	R	01FF FFFFh
FFFE:C908	DEBUG_DATA	MPUI Debug Data Register	32	R	FFFF FFFFh
FFFE:C90C	DEBUG_FLAG	MPUI Debug Flag Register	32	R	0800h
FFFE:C910	STATUS_REG	MPUI Status Register	32	R	0000h
FFFE:C914	DSP_STATUS_REG	MPUI DSP Status Register	32	R	undef
FFFE:C918	DSP_BOOT_CONFIG	MPUI Boot Configuration Register	32	RW	0000h
FFFE:C91C	DSP_MPUI_CONFIG	MPUI DSP MPUI Configuration Register	32	RW	FFFFh

Table 3–43. TIPB (Private) Bridge 1 Configuration Registers

BYTE ADDRESS	REGISTER NAME	DESCRIPTION	ACCESS WIDTH	ACCESS TYPE	RESET VALUE
FFFE:CA00	TIPB_CNTL	Private TIPB Control Register	32	RW	FF11h
FFFE:CA04	TIPB_BUS_ALLOC	Private TIPB Bus Allocation Register	32	RW	0009h
FFFE:CA08	MPU_TIPB_CNTL	Private MPU TIPB Control Register	32	RW	0000h
FFFE:CA0C	ENHANCED_TIPB_CNTL	Private Enhanced TIPB Control Register	32	RW	0007h
FFFE:CA10	ADDRESS_DBG	Private Debug Address Register	32	R	FFFFh
FFFE:CA14	DATA_DEBUG_LOW	Private Debug Data LSB Register	32	R	FFFFh
FFFE:CA18	DATA_DEBUG_HIGH	Private Debug Data MSB Register	32	R	FFFFh
FFFE:CA1C	DEBUG_CNTR_SIG	Private Debug Control Signals Register	32	R	00F8h

Table 3–44. TIPB (Public) Bridge 2 Configuration Registers

BYTE ADDRESS	REGISTER NAME	DESCRIPTION	ACCESS WIDTH	ACCESS TYPE	RESET VALUE
FFFE:D300	TIPB_CNTL	Public TIPB Control Register	16	RW	FF11h
FFFE:D304	TIPB_BUS_ALLOC	Public TIPB Bus Allocation Register	16	RW	0009h
FFFE:D308	MPU_TIPB_CNTL	Public MPU TIPB Control Register	16	RW	0000h
FFFE:D30C	ENHANCED_TIPB_CNTL	Public Enhanced TIPB Control Register	16	RW	0007h
FFFE:D310	ADDRESS_DBG	Public Debug Address Register	16	R	FFFFh
FFFE:D314	DATA_DEBUG_LOW	Public Debug Data LSB Register	16	R	FFFFh
FFFE:D318	DATA_DEBUG_HIGH	Public Debug Data MSB Register	16	R	FFFFh
FFFE:D31C	DEBUG_CNTR_SIG	Public Debug Control Signals Register	16	R	00F8h

Table 3–45. MPU UART TIPB Bus Switch Registers

BYTE ADDRESS	REGISTER NAME	DESCRIPTION	ACCESS WIDTH	ACCESS TYPE	RESET VALUE
FFFB:C800	RHSW_ARM_CNF1	UART1 TIPB Switch Configuration Register (MPU)	16	RW	0001h
FFFB:C804	RHSW_ARM_STA1	UART1 TIPB Switch Status Register (MPU)	16	R	0001h
FFFB:C808 – FFFB:C83C		Reserved			
FFFB:C840	RHSW_ARM_CNF2	UART2 TIPB Switch Configuration Register (MPU)	16	RW	0001h
FFFB:C844	RHSW_ARM_STA2	UART2 TIPB Switch Status Register (MPU)	16	R	0001h
FFFB:C848 – FFFB:C87C		Reserved			
FFFB:C880	RHSW_ARM_CNF3	UART3 TIPB Switch Configuration Register (MPU)	16	RW	0001h
FFFB:C884	RHSW_ARM_STA3	UART3 TIPB Switch Status Register (MPU)	16	R	0001h

PRODUCT PREVIEW

Table 3–46. Traffic Controller Registers

BYTE ADDRESS	REGISTER NAME	DESCRIPTION	ACCESS WIDTH	ACCESS TYPE	RESET VALUE
FFFE:CC00	IMIF_PRIO	TC IMIF Priority Register	32	RW	0000 0000h
FFFE:CC04	EMIFS_PRIO_REG	TC EMIFS Priority Register	32	RW	0000 0000h
FFFE:CC08	EMIFF_PRIO_REG	TC EMIFF Priority Register	32	RW	0000 0000h
FFFE:CC0C	EMIFS_CONFIG_REG	TC EMIFS Configuration Register	32	RW	y00z0b†
FFFE:CC10	EMIFS_CS0_CONFIG	TC EMIFS CS0 Configuration Register	32	RW	0010 FFBh
FFFE:CC14	EMIFS_CS1_CONFIG	TC EMIFS CS1 Configuration Register	32	RW	0010 FFBh
FFFE:CC18	EMIFS_CS2_CONFIG	TC EMIFS CS2 Configuration Register	32	RW	0010 FFBh
FFFE:CC1C	EMIFS_CS3_CONFIG	TC EMIFS CS3 Configuration Register	32	RW	0010 FFBh
FFFE:CC20	EMIFF_SDRAM_CONFIG	TC EMIFF SDRAM Configuration Register	32	RW	0061 8800h
FFFE:CC24	EMIFF_MRS	TC EMIFF SDRAM MRS Register	32	RW	0000 0037h
FFFE:CC28	TIMEOUT1	TC Timeout 1 Register	32	RW	0000 0000h
FFFE:CC2C	TIMEOUT2	TC Timeout 2 Register	32	RW	0000 0000h
FFFE:CC30	TIMEOUT3	TC Timeout 3 Register	32	RW	0000 0000h
FFFE:CC34	ENDIANISM	TC Endianism Register	32	RW	0000 0000h
FFFE:CC38		Reserved	32	RW	0000 0000h
FFFE:CC3C	EMIFF_SDRAM_CONFIG_2	TC EMIFF SDRAM Configuration Register 2	32	RW	0000 0003h
FFFE:CC40	EMIFS_CFG_DYN_WAIT	TC EMIFS Wait-State Configuration Register	32	RW	0000 0000h

† The value of y is dependent upon the state of the FLASH.RDY pin and the value of z is dependent upon the state of the MPU_BOOT pin upon power-on reset.

Table 3–47. MPU Clock/Reset/Power Mode Control Registers

BYTE ADDRESS	REGISTER NAME	DESCRIPTION	ACCESS WIDTH	ACCESS TYPE	RESET VALUE
FFFE:CE00	ARM_CKCTL	MPU Clock Control Register	32	RW	3000h
FFFE:CE04	ARM_IDLECT1	MPU Idle Control 1 Register	32	RW	0400h
FFFE:CE08	ARM_IDLECT2	MPU Idle Control 2 Register	32	RW	0100h
FFFE:CE0C	ARM_EWUPCT	MPU External Wakeup Control Register	32	RW	003Fh
FFFE:CE10	ARM_RSTCT1	MPU Reset Control 1 Register	32	RW	0000h
FFFE:CE14	ARM_RSTCT2	MPU Reset Control 2 Register	32	RW	0000h
FFFE:CE18	ARM_SYSST	MPU System Status Register	32	RW	0038h

Table 3–48. DPLL1 Register

BYTE ADDRESS	REGISTER NAME	DESCRIPTION	ACCESS WIDTH	ACCESS TYPE	RESET VALUE
FFFE:CF00	DPLL1_CTL_REG	DPLL1 Control Register	32	RW	0000 2002h

Table 3–49. Ultra Low-Power Device Module Registers

BYTE ADDRESS	REGISTER NAME	DESCRIPTION	ACCESS WIDTH	ACCESS TYPE	RESET VALUE
FFFE:0800	COUNTER_32_LSB	ULPD 32-kHz Counter Register LSB	16	R	0001h
FFFE:0804	COUNTER_32_MSB	ULPD 32-kHz Counter Register MSB	16	R	0001h
FFFE:0808	COUNTER_HIGH_FREQ_LSB	ULPD High-Frequency Counter LSB Register	16	R	0001h
FFFE:080C	COUNTER_HIGH_FREQ_MSB	ULPD High-Frequency Counter MSB Register	16	R	0000h
FFFE:0810	GAUGING_CTRL_REG	ULPD Gauging Control Register	16	RW	0000h
FFFE:0814	IT_STATUS_REG	ULPD Interrupt Status Register	16	R	0000h
FFFE:0818 – FFFE:0820		Reserved			
FFFE:0824	SETUP_ULPD1_REG	ULPD Wakeup Time Setup Register	16	RW	03FFh
FFFE:0828 – FFFE:082C		Reserved			
FFFE:0830	CLOCK_CTRL_REG	ULPD Clock Control Register	16	RW	0000h
FFFE:0834	SOFT_REQ_REG	ULPD Soft Clock Request Register	16	RW	0000h
FFFE:0838	COUNTER_32_FIQ_REG	ULPD Modem Shutdown Delay Register	16	RW	0001h
FFFE:083C	DPLL_CTRL_REG	ULPD USB DPLL Control Register	16	RW	2211h
FFFE:0840	STATUS_REQ_REG	ULPD Hardware Request Status Register	16	RW	undef
FFFE:0844		Reserved			
FFFE:0848	LOCK_TIME_REG	ULPD APLL Lock Time Register	16	RW	0960h
FFFE:084C	APLL_CTRL_REG	ULPD APLL Control Register	16	RW	undef
FFFE:0850	POWER_CTRL_REG	ULPD Power Control Register	16	RW	0008h

Table 3–50. Device Die Identification Registers

BYTE ADDRESS	REGISTER NAME	DESCRIPTION	ACCESS WIDTH	ACCESS TYPE	RESET VALUE
FFFE:1800	DIE_ID_LSB	Device Die Identification Register (LSB)	32	R	–
FFFE:1804	DIE_ID_MSB	Device Die Identification Register (MSB)	32	R	–

Table 3–51. JTAG Identification Code Register

BYTE ADDRESS	REGISTER NAME	DESCRIPTION	ACCESS WIDTH	ACCESS TYPE	RESET VALUE
FFFE:D404	JTAG_ID	JTAG Identification Code Register	32	R	–

3.16 DSP Register Descriptions

The following tables describe the DSP registers including register addresses, descriptions, required access widths, access types (R-read, W-write, RW-read/write) and reset values. These tables are organized by function with like peripherals or functions together and are therefore not necessarily in the order of ascending register addresses.

NOTE: All accesses to these registers must be of the data access widths indicated to avoid a TIPB bus error condition and a corresponding interrupt. Reserved addresses should never be accessed

3.16.1 DSP Private Peripheral Registers

The DSP private peripheral registers include the following:

- DMA Controller:
 - DSP DMA Controller Registers
- Timers:
 - DSP Timer 1 Registers
 - DSP Timer 2 Registers
 - DSP Timer 3 Registers
 - DSP Watchdog Timer Registers
- Interrupt Control:
 - DSP Interrupt Interface Registers
 - DSP Level 2 Interrupt Handler Registers

Table 3–52. DSP DMA Controller Registers

DSP WORD ADDRESS	REGISTER NAME	DESCRIPTION	ACCESS WIDTH	ACCESS TYPE	RESET VALUE
0x00 0C00h	DMA_CSDP0	Channel 0 Source/Destination Parameters Register	16	RW	0000h
0x00 0C01h	DMA_CCR0	Channel 0 Control Register	16	RW	0000h
0x00 0C02h	DMA_CICR0	Channel 0 Interrupt Control Register	16	RW	0003h
0x00 0C03h	DMA_CSR0	Channel 0 Status Register	16	R	0000h
0x00 0C04h	DMA_CSSA_L0	Channel 0 Source Start Address Register LSB	16	RW	undef
0x00 0C05h	DMA_CSSA_U0	Channel 0 Source Start Address Register MSB	16	RW	undef
0x00 0C06h	DMA_CDSA_L0	Channel 0 Destination Start Address Register LSB	16	RW	undef
0x00 0C07h	DMA_CDSA_U0	Channel 0 Destination Start Address Register MSB	16	RW	undef
0x00 0C08h	DMA_CEN0	Channel 0 Element Number Register	16	RW	undef
0x00 0C09h	DMA_CFN0	Channel 0 Frame Number Register	16	RW	undef
0x00 0C0Ah	DMA_CSFI0	Channel 0 Frame Index Register	16	RW	undef
0x00 0C0Bh	DMA_CSEI0	Channel 0 Element Index Register	16	RW	undef
0x00 0C0Ch	DMA_CSAC0	Channel 0 Source Address Counter Register	16	RW	undef
0x00 0C0Dh	DMA_CDAC0	Channel 0 Destination Address Counter Register	16	RW	undef
0x00 0C0Eh	DMA_CDFI0	Channel 0 Destination Frame Index	16	RW	undef
0x00 0C0Fh	DMA_CDEI0	Channel 0 Destination Element Index	16	RW	undef
0x00 0C10h – 0x00 0C1Fh		Reserved			
0x00 0C20h	DMA_CSDP1	Channel 1 Source/Destination Parameters Register	16	RW	0000h
0x00 0C21h	DMA_CCR1	Channel 1 Control Register	16	RW	0000h
0x00 0C22h	DMA_CICR1	Channel 1 Interrupt Control Register	16	RW	0003h
0x00 0C23h	DMA_CSR1	Channel 1 Status Register	16	R	0000h
0x00 0C24h	DMA_CSSA_L1	Channel 1 Source Start Address Register LSB	16	RW	undef
0x00 0C25h	DMA_CSSA_U1	Channel 1 Source Start Address Register MSB	16	RW	undef
0x00 0C26h	DMA_CDSA_L1	Channel 1 Destination Start Address Register LSB	16	RW	undef
0x00 0C27h	DMA_CDSA_U1	Channel 1 Destination Start Address Register MSB	16	RW	undef
0x00 0C28h	DMA_CEN1	Channel 1 Element Number Register	16	RW	undef
0x00 0C29h	DMA_CFN1	Channel 1 Frame Number Register	16	RW	undef
0x00 0C2Ah	DMA_CSFI1	Channel 1 Frame Index Register	16	RW	undef
0x00 0C2Bh	DMA_CSEI1	Channel 1 Element Index Register	16	RW	undef
0x00 0C2Ch	DMA_CSAC1	Channel 1 Source Address Counter Register	16	RW	undef
0x00 0C2Dh	DMA_CDAC1	Channel 1 Destination Address Counter Register	16	RW	undef
0x00 0C2Eh	DMA_CDFI1	Channel 1 Destination Frame Index	16	RW	undef
0x00 0C2Fh	DMA_CDEI1	Channel 1 Destination Element Index	16	RW	undef
0x00 0C30h – 0x00 0C3Fh		Reserved			
0x00 0C40h	DMA_CSDP2	Channel 2 Source/Destination Parameters Register	16	RW	0000h
0x00 0C41h	DMA_CCR2	Channel 2 Control Register	16	RW	0000h
0x00 0C42h	DMA_CICR2	Channel 2 Interrupt Control Register	16	RW	0003h
0x00 0C43h	DMA_CSR2	Channel 2 Status Register	16	R	0000h
0x00 0C44h	DMA_CSSA_L2	Channel 2 Source Start Address Register LSB	16	RW	undef
0x00 0C45h	DMA_CSSA_U2	Channel 2 Source Start Address Register MSB	16	RW	undef
0x00 0C46h	DMA_CDSA_L2	Channel 2 Destination Start Address Register LSB	16	RW	undef
0x00 0C47h	DMA_CDSA_U2	Channel 2 Destination Start Address Register MSB	16	RW	undef

PRODUCT PREVIEW

Table 3–52. DSP DMA Controller Registers (Continued)

DSP WORD ADDRESS	REGISTER NAME	DESCRIPTION	ACCESS WIDTH	ACCESS TYPE	RESET VALUE
0x00 0C48h	DMA_CEN2	Channel 2 Element Number Register	16	RW	undef
0x00 0C49h	DMA_CFN2	Channel 2 Frame Number Register	16	RW	undef
0x00 0C4Ah	DMA_CSF12	Channel 2 Frame Index Register	16	RW	undef
0x00 0C4Bh	DMA_CSEI2	Channel 2 Element Index Register	16	RW	undef
0x00 0C4Ch	DMA_CSAC2	Channel 2 Source Address Counter Register	16	RW	undef
0x00 0C4Dh	DMA_CDAC2	Channel 2 Destination Address Counter Register	16	RW	undef
0x00 0C4Eh	DMA_CDFI2	Channel 2 Destination Frame Index	16	RW	undef
0x00 0C4Fh	DMA_CDEI2	Channel 2 Destination Element Index	16	RW	undef
0x00 0C50h – 0x00 0C5Fh		Reserved			
0x00 0C60h	DMA_CSDP3	Channel 3 Source/Destination Parameters Register	16	RW	0000h
0x00 0C61h	DMA_CCR3	Channel 3 Control Register	16	RW	0000h
0x00 0C62h	DMA_CICR3	Channel 3 Interrupt Control Register	16	RW	0003h
0x00 0C63h	DMA_CSR3	Channel 3 Status Register	16	R	0000h
0x00 0C64h	DMA_CSSA_L3	Channel 3 Source Start Address Register LSB	16	RW	undef
0x00 0C65h	DMA_CSSA_U3	Channel 3 Source Start Address Register MSB	16	RW	undef
0x00 0C66h	DMA_CDSA_L3	Channel 3 Destination Start Address Register LSB	16	RW	undef
0x00 0C67h	DMA_CDSA_U3	Channel 3 Destination Start Address Register MSB	16	RW	undef
0x00 0C68h	DMA_CEN3	Channel 3 Element Number Register	16	RW	undef
0x00 0C69h	DMA_CFN3	Channel 3 Frame Number Register	16	RW	undef
0x00 0C6Ah	DMA_CSF13	Channel 3 Frame Index Register	16	RW	undef
0x00 0C6Bh	DMA_CSEI3	Channel 3 Element Index Register	16	RW	undef
0x00 0C6Ch	DMA_CSAC3	Channel 3 Source Address Counter Register	16	RW	undef
0x00 0C6Dh	DMA_CDAC3	Channel 3 Destination Address Counter Register	16	RW	undef
0x00 0C6Eh	DMA_CDFI3	Channel 3 Destination Frame Index	16	RW	undef
0x00 0C6Fh	DMA_CDEI3	Channel 3 Destination Element Index	16	RW	undef
0x00 0C70h – 0x00 0C7Fh		Reserved			
0x00 0C80h	DMA_CSDP4	Channel 4 Source/Destination Parameters Register	16	RW	0000h
0x00 0C81h	DMA_CCR4	Channel 4 Control Register	16	RW	0000h
0x00 0C82h	DMA_CICR4	Channel 4 Interrupt Control Register	16	RW	0003h
0x00 0C83h	DMA_CSR4	Channel 4 Status Register	16	R	0000h
0x00 0C84h	DMA_CSSA_L4	Channel 4 Source Start Address Register LSB	16	RW	undef
0x00 0C85h	DMA_CSSA_U4	Channel 4 Source Start Address Register MSB	16	RW	undef
0x00 0C86h	DMA_CDSA_L4	Channel 4 Destination Start Address Register LSB	16	RW	undef
0x00 0C87h	DMA_CDSA_U4	Channel 4 Destination Start Address Register MSB	16	RW	undef
0x00 0C88h	DMA_CEN4	Channel 4 Element Number Register	16	RW	undef
0x00 0C89h	DMA_CFN4	Channel 4 Frame Number Register	16	RW	undef
0x00 0C8Ah	DMA_CSF14	Channel 4 Frame Index Register	16	RW	undef
0x00 0C8Bh	DMA_CSEI4	Channel 4 Element Index Register	16	RW	undef
0x00 0C8Ch	DMA_CSAC4	Channel 4 Source Address Counter Register	16	RW	undef
0x00 0C8Dh	DMA_CDAC4	Channel 4 Destination Address Counter Register	16	RW	undef
0x00 0C8Eh	DMA_CDFI4	Channel 4 Destination Frame Index	16	RW	undef
0x00 0C8Fh	DMA_CDEI4	Channel 4 Destination Element Index	16	RW	undef

Table 3–52. DSP DMA Controller Registers (Continued)

DSP WORD ADDRESS	REGISTER NAME	DESCRIPTION	ACCESS WIDTH	ACCESS TYPE	RESET VALUE
0x00 0C90h – 0x00 0C9Fh		Reserved			
0x00 0CA0h	DMA_CSDP5	Channel 5 Source/Destination Parameters Register	16	RW	0000h
0x00 0CA1h	DMA_CCR5	Channel 5 Control Register	16	RW	0000h
0x00 0CA2h	DMA_CICR5	Channel 5 Interrupt Control Register	16	RW	0003h
0x00 0CA3h	DMA_CSR5	Channel 5 Status Register	16	R	0000h
0x00 0CA4h	DMA_CSSA_L5	Channel 5 Source Start Address Register LSB	16	RW	undef
0x00 0CA5h	DMA_CSSA_U5	Channel 5 Source Start Address Register MSB	16	RW	undef
0x00 0CA6h	DMA_CDSA_L5	Channel 5 Destination Start Address Register LSB	16	RW	undef
0x00 0CA7h	DMA_CDSA_U5	Channel 5 Destination Start Address Register MSB	16	RW	undef
0x00 0CA8h	DMA_CEN5	Channel 5 Element Number Register	16	RW	undef
0x00 0CA9h	DMA_CFN5	Channel 5 Frame Number Register	16	RW	undef
0x00 0CAAh	DMA_CSF15	Channel 5 Frame Index Register	16	RW	undef
0x00 0CABh	DMA_CSE15	Channel 5 Element Index Register	16	RW	undef
0x00 0CACH	DMA_CSAC5	Channel 5 Source Address Counter Register	16	RW	undef
0x00 0CADh	DMA_CDAC5	Channel 5 Destination Address Counter Register	16	RW	undef
0x00 0CAEh	DMA_CDF15	Channel 5 Destination Frame Index	16	RW	undef
0x00 0CAFh	DMA_CDE15	Channel 5 Destination Element Index	16	RW	undef
0x00 0CB0h – 0x00 0DFFh		Reserved			
0x00 0E00h	DMA_GCR	Global Control Register	16	RW	0008h
0x00 0E01h	DMA_GTCR	Global Timeout Control Register	16	RW	0000h
0x00 0E02h	DMA_GSCR	Global Software Incompatible Control Register	16	RW	0000h

PRODUCT PREVIEW

Table 3–53. DSP Timer 1 Registers

DSP WORD ADDRESS	REGISTER NAME	DESCRIPTION	ACCESS WIDTH	ACCESS TYPE	RESET VALUE
0x00 2800h	DSP_CNTL_TIMER_1	DSP Timer 1 Control Timer Register	16	RW	0000h
0x00 2801h		Reserved			
0x00 2802h	DSP_LOAD_TIM_HI_1	DSP Timer 1 Load Timer High Register	16	W	undef
0x00 2803h	DSP_LOAD_TIM_LO_1	DSP Timer 1 Load Timer Low Register	16	W	undef
0x00 2804h	DSP_READ_TIM_HI_1	DSP Timer 1 Read Timer High Register	16	R	undef
0x00 2805h	DSP_READ_TIM_LO_1	DSP Timer 1 Read Timer Low Register	16	R	undef

Table 3–54. DSP Timer 2 Registers

DSP WORD ADDRESS	REGISTER NAME	DESCRIPTION	ACCESS WIDTH	ACCESS TYPE	RESET VALUE
0x00 2C00h	DSP_CNTL_TIMER_2	DSP Timer 2 Control Timer Register	16	RW	0000h
0x00 2C01h		Reserved			
0x00 2C02h	DSP_LOAD_TIM_HI_2	DSP Timer 2 Load Timer High Register	16	W	undef
0x00 2C03h	DSP_LOAD_TIM_LO_2	DSP Timer 2 Load Timer Low Register	16	W	undef
0x00 2C04h	DSP_READ_TIM_HI_2	DSP Timer 2 Read Timer High Register	16	R	undef
0x00 2C05h	DSP_READ_TIM_LO_2	DSP Timer 2 Read Timer Low Register	16	R	undef

Table 3–55. DSP Timer 3 Registers

DSP WORD ADDRESS	REGISTER NAME	DESCRIPTION	ACCESS WIDTH	ACCESS TYPE	RESET VALUE
0x00 3000h	DSP_CNTL_TIMER_3	DSP Timer 3 Control Timer Register	16	RW	0000h
0x00 3001h		Reserved			
0x00 3002h	DSP_LOAD_TIM_HI_3	DSP Timer 3 Load Timer High Register	16	W	undef
0x00 3003h	DSP_LOAD_TIM_LO_3	DSP Timer 3 Load Timer Low Register	16	W	undef
0x00 3004h	DSP_READ_TIM_HI_3	DSP Timer 3 Read Timer High Register	16	R	undef
0x00 3005h	DSP_READ_TIM_LO_3	DSP Timer 3 Read Timer Low Register	16	R	undef

Table 3–56. DSP Watchdog Timer Registers

DSP WORD ADDRESS	REGISTER NAME	DESCRIPTION	ACCESS WIDTH	ACCESS TYPE	RESET VALUE
0x00 3400h	DSP_CNTL_TIMER_WD	DSP WDT Control Timer Register	16	RW	0002h
0x00 3401h		Reserved			
0x00 3402h	DSP_LOAD_TIM_WD	DSP WDT Load Timer Register	16	W	FFFFh
0x00 3402h	DSP_READ_TIM_WD	DSP WDT Read Timer Register	16	R	FFFFh
0x00 3403h		Reserved			
0x00 3404h	DSP_TIMER_MODE_WD	DSP WDT Timer Mode Register	16	RW	8000h

Table 3–57. DSP Interrupt Interface Registers

DSP WORD ADDRESS	REGISTER NAME	DESCRIPTION	ACCESS WIDTH	ACCESS TYPE	RESET VALUE
0x00 3800h	ET_LS_CTRL_HI	Edge Triggered/Level Sensitive Control Register High	16	RW	0000h
0x00 3801h	ET_LS_CTRL_LO	Edge Triggered/Level Sensitive Control Register Low	16	RW	0000h
0x00 3802h	RST_LVL_LO	Level Sensitive Clear Low Register	16	W	0000h
0x00 3803h	RST_LVL_HI	Level Sensitive Clear High Register	16	W	0000h

Table 3–58. DSP Level 2 Interrupt Handler Registers

DSP WORD ADDRESS	REGISTER NAME	DESCRIPTION	ACCESS WIDTH	ACCESS TYPE	RESET VALUE
0x00 4800h	DSP_L2_ITR	Interrupt Register	16	RW	0000h
0x00 4802h	DSP_L2_MIR	Mask Interrupt Register	16	RW	FFFFh
0x00 4804h	DSP_L2_SIR_IRQ_CODE	IRQ Interrupt Encoded Source Register	16	R	0000h
0x00 4806h	DSP_L2_SIR_FIQ_CODE	FIQ Interrupt Encoded Source Register	16	R	0000h
0x00 4808h	DSP_L2_CONTROL_REG	Interrupt Control Register	16	RW	0000h
0x00 480Ah	DSP_L2_ISR	Software Interrupt Set Register	16	RW	0000h
0x00 480Ch	DSP_L2_ILR0	Interrupt 0 Priority Level Register	16	RW	0000h
0x00 480Eh	DSP_L2_ILR1	Interrupt 1 Priority Level Register	16	RW	0000h
0x00 4810h	DSP_L2_ILR2	Interrupt 2 Priority Level Register	16	RW	0000h
0x00 4812h	DSP_L2_ILR3	Interrupt 3 Priority Level Register	16	RW	0000h
0x00 4814h	DSP_L2_ILR4	Interrupt 4 Priority Level Register	16	RW	0000h
0x00 4816h	DSP_L2_ILR5	Interrupt 5 Priority Level Register	16	RW	0000h
0x00 4818h	DSP_L2_ILR6	Interrupt 6 Priority Level Register	16	RW	0000h
0x00 481Ah	DSP_L2_ILR7	Interrupt 7 Priority Level Register	16	RW	0000h
0x00 481Ch	DSP_L2_ILR8	Interrupt 8 Priority Level Register	16	RW	0000h
0x00 481Eh	DSP_L2_ILR9	Interrupt 9 Priority Level Register	16	RW	0000h
0x00 4820h	DSP_L2_ILR10	Interrupt 10 Priority Level Register	16	RW	0000h
0x00 4822h	DSP_L2_ILR11	Interrupt 11 Priority Level Register	16	RW	0000h
0x00 4824h	DSP_L2_ILR12	Interrupt 12 Priority Level Register	16	RW	0000h
0x00 4826h	DSP_L2_ILR13	Interrupt 13 Priority Level Register	16	RW	0000h
0x00 4828h	DSP_L2_ILR14	Interrupt 14 Priority Level Register	16	RW	0000h
0x00 482Ah	DSP_L2_ILR15	Interrupt 15 Priority Level Register	16	RW	0000h

PRODUCT PREVIEW

3.16.2 DSP Public Peripheral Registers

The DSP public peripheral registers include the following:

- Serial Ports:
 - McBSP1 Registers
 - McBSP3 Registers
 - MCSI1 Registers
 - MCSI2 Registers

Table 3–59. McBSP1 Registers

DSP WORD ADDRESS	MPU BYTE ADDRESS (VIA MPU)	REGISTER NAME	DESCRIPTION	ACCESS WIDTH	ACCESS TYPE	RESET VALUE
0x00 8C00h	E101:1800	MCBSP1_DRR2	McBSP1 Data receive register 2	16	RW	0000h
0x00 8C01h	E101:1804	MCBSP1_DRR1	McBSP1 Data receive register 1	16	RW	0000h
0x00 8C02h	E101:1808	MCBSP1_DXR2	McBSP1 Data transmit register 2	16	RW	0000h
0x00 8C03h	E101:180C	MCBSP1_DXR1	McBSP1 Data transmit register 1	16	RW	0000h
0x00 8C04h	E101:1810	MCBSP1_SPCR2	McBSP1 Serial port control register 2	16	RW	0000h
0x00 8C05h	E101:1814	MCBSP1_SPCR1	McBSP1 Serial port control register 1	16	RW	0000h
0x00 8C06h	E101:1870	MCBSP1_RCR2	McBSP1 Receive control register 2	16	RW	0000h
0x00 8C07h	E101:181C	MCBSP1_RCR1	McBSP1 Receive control register 1	16	RW	0000h
0x00 8C08h	E101:1820	MCBSP1_XCR2	McBSP1 Transmit control register 2	16	RW	0000h
0x00 8C09h	E101:1824	MCBSP1_XCR1	McBSP1 Transmit control register 1	16	RW	0000h
0x00 8C0Ah	E101:1828	MCBSP1_SRGR2	McBSP1 Sample rate generator register 2	16	RW	2000h
0x00 8C0Bh	E101:182C	MCBSP1_SRGR1	McBSP1 Sample rate generator register 1	16	RW	0001h
0x00 8C0Ch	E101:1830	MCBSP1_MCR2	McBSP1 Multichannel register 2	16	RW	0000h
0x00 8C0Dh	E101:1834	MCBSP1_MCR1	McBSP1 Multichannel register 1	16	RW	0000h
0x00 8C0Eh	E101:1838	MCBSP1_RCERA	McBSP1 Receive channel enable register partition A	16	RW	0000h
0x00 8C0Fh	E101:183C	MCBSP1_RCERB	McBSP1 Receive channel enable register partition B	16	RW	0000h
0x00 8C10h	E101:1840	MCBSP1_XCERA	McBSP1 Transmit channel enable register partition A	16	RW	0000h
0x00 8C11h	E101:1844	MCBSP1_XCERB	McBSP1 Transmit channel enable register partition B	16	RW	0000h
0x00 8C12h	E101:1848	MCBSP1_PCR0	McBSP1 Pin control register 0	16	RW	0000h
0x00 8C13h	E101:184C	MCBSP1_RCERC	McBSP1 Receive channel enable register partition C	16	RW	0000h
0x00 8C14h	E101:1850	MCBSP1_RCERD	McBSP1 Receive channel enable register partition D	16	RW	0000h
0x00 8C15h	E101:1854	MCBSP1_XCERC	McBSP1 Transmit channel enable register partition C	16	RW	0000h
0x00 8C16h	E101:1858	MCBSP1_XCERD	McBSP1 Transmit channel enable register partition D	16	RW	0000h
0x00 8C17h	E101:185C	MCBSP1_RCERE	McBSP1 Receive channel enable register partition E	16	RW	0000h
0x00 8C18h	E101:1860	MCBSP1_RCERF	McBSP1 Receive channel enable register partition F	16	RW	0000h
0x00 8C19h	E101:1864	MCBSP1_XCERE	McBSP1 Transmit channel enable register partition E	16	RW	0000h

Table 3–59. McBSP1 Registers (Continued)

DSP WORD ADDRESS	MPU BYTE ADDRESS (VIA MPUJ)	REGISTER NAME	DESCRIPTION	ACCESS WIDTH	ACCESS TYPE	RESET VALUE
0x00 8C1Ah	E101:1868	MCBSP1_XCERF	McBSP1 Transmit channel enable register partition F	16	RW	0000h
0x00 8C1Bh	E101:186C	MCBSP1_RCERG	McBSP1 Receive channel enable register partition G	16	RW	0000h
0x00 8C1Ch	E101:1870	MCBSP1_RCERH	McBSP1 Receive channel enable register partition H	16	RW	0000h
0x00 8C1Dh	E101:1874	MCBSP1_XCERG	McBSP1 Transmit channel enable register partition G	16	RW	0000h
0x00 8C1Eh	E101:1878	MCBSP1_XCERH	McBSP1 Transmit channel enable register partition H	16	RW	0000h

Table 3–60. McBSP3 Registers

DSP WORD ADDRESS	MPU BYTE ADDRESS (VIA MPUJ)	REGISTER NAME	DESCRIPTION	ACCESS WIDTH	ACCESS TYPE	RESET VALUE
0x00 B800h	E101:7000	MCBSP3_DRR2	McBSP3 Data receive register 2	16	RW	0000h
0x00 B801h	E101:7004	MCBSP3_DRR1	McBSP3 Data receive register 1	16	RW	0000h
0x00 B802h	E101:7008	MCBSP3_DXR2	McBSP3 Data transmit register 2	16	RW	0000h
0x00 B803h	E101:700C	MCBSP3_DXR1	McBSP3 Data transmit register 1	16	RW	0000h
0x00 B804h	E101:7010	MCBSP3_SPCR2	McBSP3 Serial port control register 2	16	RW	0000h
0x00 B805h	E101:7014	MCBSP3_SPCR1	McBSP3 Serial port control register 1	16	RW	0000h
0x00 B806h	E101:7070	MCBSP3_RCR2	McBSP3 Receive control register 2	16	RW	0000h
0x00 B807h	E101:701C	MCBSP3_RCR1	McBSP3 Receive control register 1	16	RW	0000h
0x00 B808h	E101:7020	MCBSP3_XCR2	McBSP3 Transmit control register 2	16	RW	0000h
0x00 B809h	E101:7024	MCBSP3_XCR1	McBSP3 Transmit control register 1	16	RW	0000h
0x00 B80Ah	E101:7028	MCBSP3_SRGR2	McBSP3 Sample rate generator register 2	16	RW	2000h
0x00 B80Bh	E101:702C	MCBSP3_SRGR1	McBSP3 Sample rate generator register 1	16	RW	0001h
0x00 B80Ch	E101:7030	MCBSP3_MCR2	McBSP3 Multichannel register 2	16	RW	0000h
0x00 B80Dh	E101:7034	MCBSP3_MCR1	McBSP3 Multichannel register 1	16	RW	0000h
0x00 B80Eh	E101:7038	MCBSP3_RCERA	McBSP3 Receive channel enable register partition A	16	RW	0000h
0x00 B80Fh	E101:703C	MCBSP3_RCERB	McBSP3 Receive channel enable register partition B	16	RW	0000h
0x00 B810h	E101:7040	MCBSP3_XCERA	McBSP3 Transmit channel enable register partition A	16	RW	0000h
0x00 B811h	E101:7044	MCBSP3_XCERB	McBSP3 Transmit channel enable register partition B	16	RW	0000h
0x00 B812h	E101:7048	MCBSP3_PCR0	McBSP3 Pin control register 0	16	RW	0000h
0x00 B813h	E101:704C	MCBSP3_RCERC	McBSP3 Receive channel enable register partition C	16	RW	0000h
0x00 B814h	E101:7050	MCBSP3_RCERD	McBSP3 Receive channel enable register partition D	16	RW	0000h
0x00 B815h	E101:7054	MCBSP3_XCERC	McBSP3 Transmit channel enable register partition C	16	RW	0000h
0x00 B816h	E101:7058	MCBSP3_XCERD	McBSP3 Transmit channel enable register partition D	16	RW	0000h

PRODUCT PREVIEW

Table 3–60. McBSP3 Registers (Continued)

DSP WORD ADDRESS	MPU BYTE ADDRESS (VIA MPUI)	REGISTER NAME	DESCRIPTION	ACCESS WIDTH	ACCESS TYPE	RESET VALUE
0x00 B817h	E101:705C	MCBSP3_RCERE	McBSP3 Receive channel enable register partition E	16	RW	0000h
0x00 B818h	E101:7060	MCBSP3_RCERF	McBSP3 Receive channel enable register partition F	16	RW	0000h
0x00 B819h	E101:7064	MCBSP3_XCERE	McBSP3 Transmit channel enable register partition E	16	RW	0000h
0x00 B81Ah	E101:7068	MCBSP3_XCERF	McBSP3 Transmit channel enable register partition F	16	RW	0000h
0x00 B81Bh	E101:706C	MCBSP3_RCERG	McBSP3 Receive channel enable register partition G	16	RW	0000h
0x00 B81Ch	E101:7070	MCBSP3_RCERH	McBSP3 Receive channel enable register partition H	16	RW	0000h
0x00 B81Dh	E101:7074	MCBSP3_XCERG	McBSP3 Transmit channel enable register partition G	16	RW	0000h
0x00 B81Eh	E101:7078	MCBSP3_XCERH	McBSP3 Transmit channel enable register partition H	16	RW	0000h

PRODUCT PREVIEW

Table 3–61. MCSI1 Registers

DSP WORD ADDRESS	MPU BYTE ADDRESS (VIA MPUI)	REGISTER NAME	DESCRIPTION	ACCESS WIDTH	ACCESS TYPE	RESET VALUE
0x00 9400h	E101:2800	MCSI1_CONTROL_REG	MCSI1 Control Register	16	RW	0000h
0x00 9401h	E101:2804	MCSI1_MAIN_PARAMETERS_REG	MCSI1 Main Parameters Register	16	RW	0000h
0x00 9402h	E101:2808	MCSI1_INTERRUPTS_REG	MCSI1 Interrupts Register	16	RW	0000h
0x00 9403h	E101:280C	MCSI1_CHANNEL_USED_REG	MCSI1 Channel Used Register	16	RW	0000h
0x00 9404h	E101:2810	MCSI1_OVER_CLOCK_REG	MCSI1 Over-Clock Register	16	RW	0000h
0x00 9405h	E101:2814	MCSI1_CLOCK_FREQUENCY_REG	MCSI1 Clock Frequency Register	16	RW	0000h
0x00 9406h	E101:2818	MCSI1_STATUS_REG	MCSI1 Status Register	16	RW	0000h
0x00 9407h – 0x00 941Fh		Reserved				
0x00 9420h	E101:2880	MCSI1_TX0	MCSI1 Transmit Word Register 0	16	RW	undef
0x00 9421h	E101:2884	MCSI1_TX1	MCSI1 Transmit Word Register 1	16	RW	undef
0x00 9422h	E101:2888	MCSI1_TX2	MCSI1 Transmit Word Register 2	16	RW	undef
0x00 9423h	E101:288C	MCSI1_TX3	MCSI1 Transmit Word Register 3	16	RW	undef
0x00 9424h	E101:2890	MCSI1_TX4	MCSI1 Transmit Word Register 4	16	RW	undef
0x00 9425h	E101:2894	MCSI1_TX5	MCSI1 Transmit Word Register 5	16	RW	undef
0x00 9426h	E101:2898	MCSI1_TX6	MCSI1 Transmit Word Register 6	16	RW	undef
0x00 9427h	E101:289C	MCSI1_TX7	MCSI1 Transmit Word Register 7	16	RW	undef
0x00 9428h	E101:28A0	MCSI1_TX8	MCSI1 Transmit Word Register 8	16	RW	undef
0x00 9429h	E101:28A4	MCSI1_TX9	MCSI1 Transmit Word Register 9	16	RW	undef
0x00 942Ah	E101:28A8	MCSI1_TX10	MCSI1 Transmit Word Register 10	16	RW	undef
0x00 942Bh	E101:28AC	MCSI1_TX11	MCSI1 Transmit Word Register 11	16	RW	undef
0x00 942Ch	E101:28B0	MCSI1_TX12	MCSI1 Transmit Word Register 12	16	RW	undef
0x00 942Dh	E101:28B4	MCSI1_TX13	MCSI1 Transmit Word Register 13	16	RW	undef
0x00 942Eh	E101:28B8	MCSI1_TX14	MCSI1 Transmit Word Register 14	16	RW	undef
0x00 942Fh	E101:28BC	MCSI1_TX15	MCSI1 Transmit Word Register 15	16	RW	undef
0x00 9430h	E101:28C0	MCSI1_RX0	MCSI1 Receive Word Register 0	16	R	undef
0x00 9431h	E101:28C4	MCSI1_RX1	MCSI1 Receive Word Register 1	16	R	undef
0x00 9432h	E101:28C8	MCSI1_RX2	MCSI1 Receive Word Register 2	16	R	undef
0x00 9433h	E101:28CC	MCSI1_RX3	MCSI1 Receive Word Register 3	16	R	undef
0x00 9434h	E101:28D0	MCSI1_RX4	MCSI1 Receive Word Register 4	16	R	undef
0x00 9435h	E101:28D4	MCSI1_RX5	MCSI1 Receive Word Register 5	16	R	undef
0x00 9436h	E101:28D8	MCSI1_RX6	MCSI1 Receive Word Register 6	16	R	undef
0x00 9437h	E101:28DC	MCSI1_RX7	MCSI1 Receive Word Register 7	16	R	undef
0x00 9438h	E101:28E0	MCSI1_RX8	MCSI1 Receive Word Register 8	16	R	undef
0x00 9439h	E101:28E4	MCSI1_RX9	MCSI1 Receive Word Register 9	16	R	undef
0x00 943Ah	E101:28E8	MCSI1_RX10	MCSI1 Receive Word Register 10	16	R	undef
0x00 943Bh	E101:28EC	MCSI1_RX11	MCSI1 Receive Word Register 11	16	R	undef
0x00 943Ch	E101:28F0	MCSI1_RX12	MCSI1 Receive Word Register 12	16	R	undef
0x00 943Dh	E101:28F4	MCSI1_RX13	MCSI1 Receive Word Register 13	16	R	undef
0x00 943Eh	E101:28F8	MCSI1_RX14	MCSI1 Receive Word Register 14	16	R	undef
0x00 943Fh	E101:28FC	MCSI1_RX15	MCSI1 Receive Word Register 15	16	R	undef

Table 3–62. MCSI2 Registers

DSP WORD ADDRESS	MPU BYTE ADDRESS (VIA MPUI)	REGISTER NAME	DESCRIPTION	ACCESS WIDTH	ACCESS TYPE	RESET VALUE
0x00 9000h	E101:2000	MCSI2_CONTROL_REG	MCSI2 Control Register	16	RW	0000h
0x00 9001h	E101:2004	MCSI2_MAIN_PARAMETERS_REG	MCSI2 Main Parameters Register	16	RW	0000h
0x00 9002h	E101:2008	MCSI2_INTERRUPTS_REG	MCSI2 Interrupts Register	16	RW	0000h
0x00 9003h	E101:200C	MCSI2_CHANNEL_USED_REG	MCSI2 Channel Used Register	16	RW	0000h
0x00 9004h	E101:2010	MCSI2_OVER_CLOCK_REG	MCSI2 Over-Clock Register	16	RW	0000h
0x00 9005h	E101:2014	MCSI2_CLOCK_FREQUENCY_REG	MCSI2 Clock Frequency Register	16	RW	0000h
0x00 9006h	E101:2018	MCSI2_STATUS_REG	MCSI2 Status Register	16	RW	0000h
0x00 9007h – 0x00 901Fh		Reserved				
0x00 9020h	E101:2080	MCSI2_TX0	MCSI2 Transmit Word Register 0	16	RW	undef
0x00 9021h	E101:2084	MCSI2_TX1	MCSI2 Transmit Word Register 1	16	RW	undef
0x00 9022h	E101:2088	MCSI2_TX2	MCSI2 Transmit Word Register 2	16	RW	undef
0x00 9023h	E101:208C	MCSI2_TX3	MCSI2 Transmit Word Register 3	16	RW	undef
0x00 9024h	E101:2048	MCSI2_TX4	MCSI2 Transmit Word Register 4	16	RW	undef
0x00 9025h	E101:2094	MCSI2_TX5	MCSI2 Transmit Word Register 5	16	RW	undef
0x00 9026h	E101:2098	MCSI2_TX6	MCSI2 Transmit Word Register 6	16	RW	undef
0x00 9027h	E101:209C	MCSI2_TX7	MCSI2 Transmit Word Register 7	16	RW	undef
0x00 9028h	E101:20A0	MCSI2_TX8	MCSI2 Transmit Word Register 8	16	RW	undef
0x00 9029h	E101:20A4	MCSI2_TX9	MCSI2 Transmit Word Register 9	16	RW	undef
0x00 902Ah	E101:20A8	MCSI2_TX10	MCSI2 Transmit Word Register 10	16	RW	undef
0x00 902Bh	E101:20AC	MCSI2_TX11	MCSI2 Transmit Word Register 11	16	RW	undef
0x00 902Ch	E101:20B0	MCSI2_TX12	MCSI2 Transmit Word Register 12	16	RW	undef
0x00 902Dh	E101:20B4	MCSI2_TX13	MCSI2 Transmit Word Register 13	16	RW	undef
0x00 902Eh	E101:20B8	MCSI2_TX14	MCSI2 Transmit Word Register 14	16	RW	undef
0x00 902Fh	E101:20BC	MCSI2_TX15	MCSI2 Transmit Word Register 15	16	RW	undef
0x00 9030h	E101:20C0	MCSI2_RX0	MCSI2 Receive Word Register 0	16	R	undef
0x00 9031h	E101:20C4	MCSI2_RX1	MCSI2 Receive Word Register 1	16	R	undef
0x00 9032h	E101:20C8	MCSI2_RX2	MCSI2 Receive Word Register 2	16	R	undef
0x00 9033h	E101:20CC	MCSI2_RX3	MCSI2 Receive Word Register 3	16	R	undef
0x00 9034h	E101:20D0	MCSI2_RX4	MCSI2 Receive Word Register 4	16	R	undef
0x00 9035h	E101:20D4	MCSI2_RX5	MCSI2 Receive Word Register 5	16	R	undef
0x00 9036h	E101:20D8	MCSI2_RX6	MCSI2 Receive Word Register 6	16	R	undef
0x00 9037h	E101:20DC	MCSI2_RX7	MCSI2 Receive Word Register 7	16	R	undef
0x00 9038h	E101:20E0	MCSI2_RX8	MCSI2 Receive Word Register 8	16	R	undef
0x00 9039h	E101:20E4	MCSI2_RX9	MCSI2 Receive Word Register 9	16	R	undef
0x00 903Ah	E101:20E8	MCSI2_RX10	MCSI2 Receive Word Register 10	16	R	undef
0x00 903Bh	E101:20EC	MCSI2_RX11	MCSI2 Receive Word Register 11	16	R	undef
0x00 903Ch	E101:20F0	MCSI2_RX12	MCSI2 Receive Word Register 12	16	R	undef
0x00 903Dh	E101:20F4	MCSI2_RX13	MCSI2 Receive Word Register 13	16	R	undef
0x00 903Eh	E101:20F8	MCSI2_RX14	MCSI2 Receive Word Register 14	16	R	undef
0x00 903Fh	E101:20FC	MCSI2_RX15	MCSI2 Receive Word Register 15	16	R	undef

3.16.3 DSP Configuration Registers

The DSP configuration registers include the following:

- I-Cache and EMIF setup
 - DSP Instruction Cache Registers
 - DSP EMIF Configuration Registers
- TIPB setup
 - DSP TIPB Bridge Configuration Registers
 - DSP UART TI Peripheral Bus Switch Registers
- Clock Control:
 - DSP Clock Mode Registers

Table 3–63. DSP Instruction Cache Registers

DSP WORD ADDRESS	REGISTER NAME	DESCRIPTION	ACCESS WIDTH	ACCESS TYPE	RESET VALUE
0x00 1400h	ICGC	I-Cache Global Control Register	16	RW	C006h
0x00 1401h		Reserved	16	RW	0000h
0x00 1402h		Reserved	16	RW	0000h
0x00 1403h	ICWC	I-Cache Way Control Register	16	RW	000Dh
0x00 1404h	ICST	I-Cache Status Register	16	R	0000h
0x00 1405h	ICRC1	I-Cache Ramset 1 Control Register	16	RW	000Dh
0x00 1406h	ICRTAG1	I-Cache Remset 1 TAG Register	16	RW	0000h
0x00 1407h	ICRC2	I-Cache Ramset 2 Control Register	16	RW	000Dh
0x00 1408h	ICRTAG2	I-Cache Remset 2 TAG Register	16	RW	0000h

Table 3–64. DSP EMIF Configuration Register

WORD ADDRESS	REGISTER NAME	DESCRIPTION	ACCESS WIDTH	ACCESS TYPE	RESET VALUE
0x00 0800h	DSP_EMIF_GCR	DSP EMIF Global Control Register	16	RW	0020h
0x00 0801h	DSP_EMIF_GRR	DSP EMIF Global Reset Register	16	RW	undef

Table 3–65. DSP TIPB Bridge Configuration Registers

WORD ADDRESS	REGISTER NAME	DESCRIPTION	ACCESS WIDTH	ACCESS TYPE	RESET VALUE
0x00 0000h	TIPB_CMR	DSP TIPB Bridge Control Mode Register	16	RW	FE4Dh
0x00 0001h	TIPB_ICR	DSP TIPB Bridge Idle Control Register	16	RW	0000h
0x00 0002h	TIPB_ISTR	DSP TIPB Bridge Idle Status Register	16	R	0000h

Table 3–66. DSP UART TIPB Bus Switch Registers

WORD ADDRESS	REGISTER NAME	DESCRIPTION	ACCESS WIDTH	ACCESS TYPE	RESET VALUE
0x00 E400h	RHSW_DSP_CNF1	UART1 TIPB Switch Configuration Register (DSP)	16	RW	0001h
0x00 E402h	RHSW_DSP_STA1	UART1 TIPB Switch Status Register (DSP)	16	R	0001h
0x00 E404– 0x00 E0Eh		Reserved			
0x00 E410h	RHSW_DSP_CNF2	UART2 TIPB Switch Configuration Register (DSP)	16	RW	0001h
0x00 E412h	RHSW_DSP_STA2	UART2 TIPB Switch Status Register (DSP)	16	R	0001h
0x00 E414– 0x00 E1Eh		Reserved			
0x00 E420h	RHSW_DSP_CNF3	UART3 TIPB Switch Configuration Register (DSP)	16	RW	0001h
0x00 E422h	RHSW_DSP_STA3	UART3 TIPB Switch Status Register (DSP)	16	R	0001h

Table 3–67. DSP Clock Mode Registers

DSP WORD ADDRESS	MPU BYTE ADDRESS (VIA MPU)	REGISTER NAME	DESCRIPTION	ACCESS WIDTH	ACCESS TYPE	RESET VALUE
0x00 4000h	E100:8000	DSP_CKCTL	DSP Clock Control Register	16	RW	0000h
0x00 4002h	E100:8004	DSP_IDLECT1	DSP Idle Control 1 Register	16	RW	0000h
0x00 4004h	E100:8008	DSP_IDLECT2	DSP Idle Control 2 Register	16	RW	0000h
0x00 4006h – 0x00 4008h		Reserved				
0x00 400Ah	E100:8014	DSP_RSTCT2	DSP Peripheral Reset Control Register	16	RW	0000h
0x00 400Ch	E100:8018	DSP_SYSST	DSP System Status Register	16	RW	0000h

3.16.4 MPU/DSP Shared Peripheral Register Descriptions

The following tables describe the MPU/DSP shared peripheral registers including register addresses, descriptions, required access widths, access types (R-read, W-write, RW-read/write) and reset values. These tables are organized by function with like peripherals or functions together and are therefore not necessarily in order of ascending register addresses. Reserved addresses should never be accessed.

NOTE: All accesses to these registers must be of the data access widths indicated to avoid a TIPB bus error condition and a corresponding interrupt. Reserved addresses should never be accessed.

The MPU/DSP shared peripheral registers include the following:

- UARTs:
 - UART1 Registers
 - UART2 Registers
 - UART3/IrDA Registers
- GPIO and Mailboxes
 - MPU/DSP Shared GPIO Registers
 - MPU/DSP Shared Mailbox Registers

Table 3–68. UART1 Registers

DSP WORD ADDRESS	MPU BYTE ADDRESS	REGISTER NAME	DESCRIPTION	ACCESS WIDTH	ACCESS TYPE	RESET VALUE
0x00 8000h	FFFB:0000	UART1_RHR†	UART1 Receive Holding Register	8	R	undef
0x00 8000h	FFFB:0000	UART1_THR†	UART1 Transmit Holding Register	8	W	undef
0x00 8000h	FFFB:0000	UART1_DLL‡§	UART1 Divisor Latch low Register	8	RW	00h
0x00 8001h	FFFB:0004	UART1_IER†	UART1 Interrupt Enable Register	8	RW	00h
0x00 8001h	FFFB:0004	UART1_DLH‡§	UART1 Divisor Latch high Register	8	RW	00h
0x00 8002h	FFFB:0008	UART1_IIR†‡	UART1 Interrupt Identification Register	8	R	01h
0x00 8002h	FFFB:0008	UART1_FCR†‡¶	UART1 FIFO Control Register	8	W	00h
0x00 8002h	FFFB:0008	UART1_EFR§	UART1 Enhanced Feature Register	8	RW	00h
0x00 8003h	FFFB:000C	UART1_LCR	UART1 Line Control Register	8	RW	00h
0x00 8004h	FFFB:0010	UART1_MCR†‡¶	UART1 Modem Control Register	8	RW	00h
0x00 8004h	FFFB:0010	UART1_XON1§	UART1 XON1 Register	8	RW	00h
0x00 8005h	FFFB:0014	UART1_LSR†‡	UART1 Mode Register	8	R	60h
0x00 8005h	FFFB:0014	UART1_XON2§	UART1 XON2 Register	8	RW	00h
0x00 8006h	FFFB:0018	UART1_MSR†‡	UART1 Modem Status Register	8	R	undef
0x00 8006h	FFFB:0018	UART1_TCR#	UART1 Transmission Control Register	8	RW	0Fh
0x00 8006h	FFFB:0018	UART1_XOFF1§	UART1 XOFF1 Register	8	RW	00h
0x00 8007h	FFFB:001C	UART1_SPR†‡	UART1 Scratchpad Register	8	RW	00h
0x00 8007h	FFFB:001C	UART1_TLR#	UART1 Trigger Level Register	8	RW	00h
0x00 8007h	FFFB:001C	UART1_XOFF2§	UART1 XOFF2 Register	8	RW	00h
0x00 8008h	FFFB:0020	UART1_MDR1	UART1 Mode Definition 1 Register	8	RW	07h
0x00 8009h – 0x00 800Dh	FFFB:0024 – FFFB:0034		Reserved			
0x00 800Eh	FFFB:0038	UART1_UASR‡§	UART1 Autobauding Status Register	8	R	00h
0x00 800Fh	FFFB:003C		Reserved			
0x00 8011h	FFFB:0044	UART1_SSR	UART1 Supplementary Status Register	8	R	00h
0x00 8012h	FFFB:0048		Reserved			
0x00 8013h	FFFB:004C	UART1_OSC_12M_SEL†	UART1 12-MHZ Oscillator Select Register	8	W	00h
0x00 8014h	FFFB:0050	UART1_MVR	UART1 Module Version Register	8	R	–

† Register is accessible when LCR[7] = 0 (normal operating mode)

‡ Register is accessible when LCR[7] = 1 and LCR[7:0] ≠ 0BFh

§ Register is accessible when LCR[7] = 0BFh

¶ Register is write accessible when EFR[4] = 1

Register is accessible when EFR[4] = 1 and MCR[6] = 1

Table 3–69. UART2 Registers

DSP WORD ADDRESS	MPU BYTE ADDRESS	REGISTER NAME	DESCRIPTION	ACCESS WIDTH	ACCESS TYPE	RESET VALUE
0x00 8400h	FFFB:0800	UART2_RHR†	UART2 Receive Holding Register	8	R	undef
0x00 8400h	FFFB:0800	UART2_THR†	UART2 Transmit Holding Register	8	W	undef
0x00 8400h	FFFB:0800	UART2_DLL‡§	UART2 Divisor Latch low Register	8	RW	00h
0x00 8401h	FFFB:0804	UART2_IER†	UART2 Interrupt Enable Register	8	RW	00h
0x00 8401h	FFFB:0804	UART2_DLH‡§	UART2 Divisor Latch high Register	8	RW	00h
0x00 8402h	FFFB:0808	UART2_IIR†‡	UART2 Interrupt Identification Register	8	R	01h
0x00 8402h	FFFB:0808	UART2_FCR†‡¶	UART2 FIFO Control Register	8	W	00h
0x00 8402h	FFFB:0808	UART2_EFR§	UART2 Enhanced Feature Register	8	RW	00h
0x00 8403h	FFFB:080C	UART2_LCR	UART2 Line Control Register	8	RW	00h
0x00 8404h	FFFB:0810	UART2_MCR†‡¶	UART2 Modem Control Register	8	RW	00h
0x00 8404h	FFFB:0810	UART2_XON1§	UART2 XON1 Register	8	RW	00h
0x00 8405h	FFFB:0814	UART2_LSR†‡	UART2 Mode Register	8	R	60h
0x00 8405h	FFFB:0814	UART2_XON2§	UART2 XON2 Register	8	RW	00h
0x00 8406h	FFFB:0818	UART2_MSR†‡	UART2 Modem Status Register	8	R	undef
0x00 8406h	FFFB:0818	UART2_TCR#	UART2 Transmission Control Register	8	RW	0Fh
0x00 8406h	FFFB:0818	UART2_XOFF1§	UART2 XOFF1 Register	8	RW	00h
0x00 8407h	FFFB:081C	UART2_SPR†‡	UART2 Scratchpad Register	8	RW	00h
0x00 8407h	FFFB:081C	UART2_TLR#	UART2 Trigger Level Register	8	RW	00h
0x00 8407h	FFFB:081C	UART2_XOFF2§	UART2 XOFF2 Register	8	RW	00h
0x00 8408h	FFFB:0820	UART2_MDR1	UART2 Mode Definition 1 Register	8	RW	07h
0x00 8409 – 0x00840Dh	FFFB:0824 – FFFB:0834		Reserved			
0x00 840Eh	FFFB:0838	UART2_UASR‡§	UART2 Autobauding Status Register	8	R	00h
0x00 840Fh	FFFB:083C		Reserved			
0x00 8410h	FFFB:0840	UART2_SCR	UART2 Supplementary Control Register	8	RW	00h
0x00 8411h	FFFB:0844	UART2_SSR	UART2 Supplementary Status Register	8	R	00h
0x00 8412h	FFFB:0848		Reserved			
0x00 8413h	FFFB:084C	UART2_OSC_12 M_SELV†	UART2 12-MHZ Oscillator Select Register	8	W	00h
0x00 8414h	FFFB:0850	UART2_MVR	UART2 Module Version Register	8	R	–

† Register is accessible when LCR[7] = 0 (normal operating mode)

‡ Register is accessible when LCR[7] = 1 and LCR[7:0] ≠ 0BFh

§ Register is accessible when LCR[7] = 0BFh

¶ Register is write accessible when EFR[4] = 1

Register is accessible when EFR[4] = 1 and MCR[6] = 1

Table 3–70. UART3/IrDA Registers

DSP WORD ADDRESS	MPU BYTE ADDRESS	REGISTER NAME	DESCRIPTION	ACCESS WIDTH	ACCESS TYPE	RESET VALUE
0x00 CC00h	FFFB:9800	UART3_RHR†	UART3 Receive Holding Register	8	R	undef
0x00 CC00h	FFFB:9800	UART3_THR†	UART3 Transmit Holding Register	8	W	undef
0x00 CC00h	FFFB:9800	UART3_DLL‡§	UART3 Divisor Latch low Register	8	RW	00h
0x00 CC01h	FFFB:9804	UART3_IER†	UART3 Interrupt Enable Register	8	RW	00h
0x00 CC01h	FFFB:9804	UART3_DLH‡§	UART3 Divisor Latch high Register	8	RW	00h
0x00 CC02h	FFFB:9808	UART3_IIR†‡	UART3 Interrupt Identification Register	8	R	01h
0x00 CC02h	FFFB:9808	UART3_FCR†‡¶	UART3 FIFO Control Register	8	W	00h
0x00 CC02h	FFFB:9808	UART3_EFR§	UART3 Enhanced Feature Register	8	RW	00h
0x00 CC03h	FFFB:980C	UART3_LCR	UART3 Line Control Register	8	RW	00h
0x00 CC04h	FFFB:9810	UART3_MCR†‡¶	UART3 Modem Control Register	8	RW	00h
0x00 CC04h	FFFB:9810	UART3_XON1§	UART3 XON1 Register	8	RW	00h
0x00 CC05h	FFFB:9814	UART3_LSR†‡	UART3 Mode Register	8	R	60h
0x00 CC05h	FFFB:9814	UART3_XON2§	UART3 XON2 Register	8	RW	00h
0x00 CC06h	FFFB:9818	UART3_MSRT†‡	UART3 Modem Status Register	8	R	undef
0x00 CC06h	FFFB:9818	UART3_TCR#	UART3 Transmission Control Register	8	RW	0Fh
0x00 CC06h	FFFB:9818	UART3_XOFF1§	UART3 XOFF1 Register	8	RW	00h
0x00 CC07h	FFFB:981C	UART3_SPR†‡	UART3 Scratchpad Register	8	RW	00h
0x00 CC07h	FFFB:981C	UART3_TLR#	UART3 Trigger Level Register	8	RW	00h
0x00 CC07h	FFFB:981C	UART3_XOFF2§	UART3 XOFF2 Register	8	RW	00h
0x00 CC08h	FFFB:9820	UART3_MDR1	UART3 Mode Definition 1 Register	8	RW	07h
0x00 CC09h	FFFB:9824	UART3_MDR2	UART3 Mode Definition Register 2	8	RW	00h
0x00 CC0Ah	FFFB:9828	UART3_SFLSR	UART3 Status FIFO Line Status Register	8	R	00h
0x00 CC0Ah	FFFB:9828	UART3_TXFLL	UART3 Transmit Frame Length Low	8	W	00h
0x00 CC0Bh	FFFB:982C	UART3_RESUME	UART3 Resume Register	8	R	00h
0x00 CC0Bh	FFFB:982C	UART3_TXFLH	UART3 Transmit Frame Length High	8	W	00h
0x00 CC0Ch	FFFB:9830	UART3_SFREGL	UART3 Status FIFO Low Register	8	R	undef
0x00 CC0Ch	FFFB:9830	UART3_RXFLL	UART3 Receive Frame Length Low	8	W	00h
0x00 CC0Dh	FFFB:9834	UART3_SFREGH	UART3 Status FIFO High Register	8	R	undef
0x00 CC0Dh	FFFB:9834	UART3_RXFLH	UART3 Receive Frame Length High	8	W	00h
0x00 CC0Eh	FFFB:9838	UART3_BLR†	UART3 BOF Control Register	8	RW	40h
0x00 CC0Fh	FFFB:983C	UART3_ACREG†	UART3 Auxiliary Control Register	8	RW	00h
0x00 CC0Fh	FFFB:983C	UART3_DIV16‡§	UART3 Divide 1.6 Register	8	RW	00h
0x00 CC10h	FFFB:9840	UART3_SCR	UART3 Supplementary Control Register	8	RW	00h
0x00 CC11h	FFFB:9844	UART3_SSR	UART3 Supplementary Status Register	8	R	00h
0x00 CC12h	FFFB:9848	UART3_EBLR†	UART3 BOF Length Register	8	W	00h
0x00 CC13h	FFFB:984C	UART3_OSC_12M_SEL†	UART3 OSC 12MHz Select Register	8	W	00h
0x00 CC14h	FFFB:9850	UART3_MVR	UART3 Module Version Register	8	R	–

† Register is accessible when LCR[7] = 0 (normal operating mode)

‡ Register is accessible when LCR[7] = 1 and LCR[7:0] ≠ 0BFh

§ Register is accessible when LCR[7] = 0BFh

¶ Register is write accessible when EFR[4] = 1

Register is accessible when EFR[4] = 1 and MCR[6] = 1

Table 3–71. MPU/DSP Shared GPIO Registers

DSP WORD ADDRESS	MPU BYTE ADDRESS	REGISTER NAME	DESCRIPTION	ACCESS WIDTH	MPU ACCESS	DSP ACCESS	RESET VALUE
0x00 F000h	FFFC:E000	DATA_INPUT	Data Input Register	16	R	R	0000h
0x00 F002h	FFFC:E004	DATA_OUTPUT	Data Output Register	16	RW	RW	FFFFh
0x00 F004h	FFFC:E008	DIRECTION_CONTROL	Direction Control Register	16	RW	RW	FFFFh
0x00 F006h	FFFC:E00C	INTERRUPT_CONTROL	Interrupt Control Register	16	RW	RW	FFFFh
0x00 F008h	FFFC:E010	INTERRUPT_MASK	Interrupt Mask Register	16	RW	RW	FFFFh
0x00 F00Ah	FFFC:E014	INTERRUPT_STATUS	Interrupt Status Register	16	RW	RW	0000h
0x00 F00Ch	FFFC:E018	PIN_CONTROL	Pin Control Register	16	RW	R	FFFFh

Table 3–72. MPU/DSP Shared Mailbox Registers

DSP WORD ADDRESS	MPU BYTE ADDRESS	REGISTER NAME	DESCRIPTION	ACCESS WIDTH	MPU ACCESS TYPE	DSP ACCESS TYPE	RESET VALUE
0x00 F800h	FFFC:F000	ARM2DSP1	MPU to DSP 1 Data Register	16	RW	R	0000h
0x00 F802h	FFFC:F004	ARM2DSP1B	MPU to DSP 1 Command Register	16	RW	R	0000h
0x00 F804h	FFFC:F008	DSP2ARM1	DSP to MPU 1 Data Register	16	R	RW	0000h
0x00 F806h	FFFC:F00C	DSP2ARM1B	DSP to MPU 1 Command Register	16	R	RW	0000h
0x00 F808h	FFFC:F010	DSP2ARM2	DSP to MPU 2 Data Register	16	R	RW	0000h
0x00 F80Ah	FFFC:F014	DSP2ARM2B	DSP to MPU 2 Command Register	16	R	RW	0000h
0x00 F80Ch	FFFC:F018	ARM2DSP1_FLAG	MPU to DSP 1 Flag Register	16	R	R	undef
0x00 F80Eh	FFFC:F01C	DSP2ARM1_FLAG	DSP to MPU 1 Flag Register	16	R	R	undef
0x00 F810h	FFFC:F020	DSP2ARM2_FLAG	DSP to MPU 2 Flag Register	16	R	R	undef
0x00 F812h	FFFC:F024	ARM2DSP2	MPU to DSP 2 Data Register	16	RW	R	0000h
0x00 F814h	FFFC:F028	ARM2DSP2B	MPU to DSP 2 Command Register	16	RW	R	0000h
0x00 F816h	FFFC:F02C	ARM2DSP2_FLAG	MPU to DSP 2 Flag Register	16	R	R	undef

PRODUCT PREVIEW

3.17 Interrupts

Table 3–73. MPU Level 1 and Level 2 Interrupt Mappings

INTERRUPT	DEFAULT SENSITIVITY	LEVEL 1 MAPPING	LEVEL 2 MAPPING	FUNCTION
Level 2 Interrupt handler FIQ	Level	IRQ_0	–	FIQ Interrupt from Level 2 Handler
CAMERA_IF_INTERRUPT	Level	IRQ_1	–	Camera Interface Interrupt
Reserved	–	IRQ_2	–	Reserved, keep masked
External FIQ	Edge	IRQ_3	–	External FIQ Interrupt
McBSP2 TX INT	Edge	IRQ_4	–	McBSP2 Transmit Interrupt
McBSP2 RX INT	Edge	IRQ_5	–	McBSP2 Receive Interrupt
IRQ_RTDX	Level	IRQ_6	–	Real-Time Data Exchange Interrupt (for RTDX Emulation Tools)
IRQ_DSP_MMU_ABORT	Level	IRQ_7	–	DSP MMU Abort Interrupt
IRQ_HOST_INT	Level	IRQ_8	–	
IRQ_ABORT	Level	IRQ_9	–	
IRQ_DSP_MAILBOX1	Level	IRQ_10	–	
IRQ_DSP_MAILBOX2	Level	IRQ_11	–	
Reserved	–	IRQ_12	–	Reserved, keep masked
IRQ_TIPB_BRIDGE_PRIVATE	Level	IRQ_13	–	TIPB Private Bridge Interrupt
IRQ_GPIO	Level	IRQ_14	–	MPU Interrupt for MPU-owned shared GPI
IRQ_UART3	Level	IRQ_15	–	UART3 Interrupt
IRQ_TIMER3	Edge	IRQ_16	–	MPU Timer 3 Interrupt
IRQ_LB_MMU	Level	IRQ_17	–	Local Bus MMU Interrupt
Reserved	–	IRQ_18	–	Reserved, keep masked
IRQ_DMA_CH0_CH6	Level	IRQ_19	–	System DMA Channel 0 and 6 Interrupt
IRQ_DMA_CH1_CH7	Level	IRQ_20	–	System DMA Channel 1 and 7 Interrupt
IRQ_DMA_CH2_CH8	Level	IRQ_21	–	System DMA Channel 2 and 8 Interrupt
IRQ_DMA_CH3	Level	IRQ_22	–	System DMA Channel 3 Interrupt
IRQ_DMA_CH4	Level	IRQ_23	–	System DMA Channel 4 Interrupt
IRQ_DMA_CH5	Level	IRQ_24	–	System DMA Channel 5 Interrupt
IRQ_DMA_CH_LCD	Level	IRQ_25	–	System DMA LCD Channel Interrupt
IRQ_TIMER1	Edge	IRQ_26	–	MPU Timer 1 Interrupt
IRQ_WD_TIMER	Edge	IRQ_27	–	MPU Watchdog Timer Interrupt
IRQ_TIPB_BRIDGE_PUBLIC	Level	IRQ_28	–	TIPB Public Bridge Interrupt
IRQ_LOCAL_BUS_IF	Level	IRQ_29	–	Local Bus Interrupt
IRQ_TIMER2	Edge	IRQ_30	–	MPU Timer 2 Interrupt
IRQ_LCD_CTRL	Level	IRQ_31	–	LCD Controller Interrupt
FAC	Level	IRQ_0	IRQ_0	Frame Adjustment Counter Interrupt
KBD	Edge	IRQ_0	IRQ_1	Keyboard Interrupt
MICROWIRE_TX	Edge	IRQ_0	IRQ_2	Microwire Transmit Interrupt
MICROWIRE_RX	Edge	IRQ_0	IRQ_3	Microwire Receive Interrupt
I2C	Edge	IRQ_0	IRQ_4	I ² C Interrupt
MPUIO	Level	IRQ_0	IRQ_5	MPUIO Interrupt

Table 3–73. MPU Level 1 and Level 2 Interrupt Mappings (Continued)

INTERRUPT	DEFAULT SENSITIVITY	LEVEL 1 MAPPING	LEVEL 2 MAPPING	FUNCTION
USB_HCC1	Level	IRQ_0	IRQ_6	USB Host HCC1 Interrupt
USB_HCC2	Edge	IRQ_0	IRQ_7	USB Host HCC2 Interrupt
Reserved	–	IRQ_0	IRQ_8	
Reserved	–	IRQ_0	IRQ_9	
MCBSP3_TX_INT	Edge	IRQ_0	IRQ_10	McBSP3 Transmit Interrupt
MCBSP3_RX_INT	Edge	IRQ_0	IRQ_11	McBSP3 Receive Interrupt
MCBSP1_TX_INT	Edge	IRQ_0	IRQ_12	McBSP1 Transmit Interrupt
MCBSP1_RX_INT	Edge	IRQ_0	IRQ_13	McBSP1 Receive Interrupt
UART1	Level	IRQ_0	IRQ_14	UART1 Interrupt
UART2	Level	IRQ_0	IRQ_15	UART2 Interrupt
MCSI1_TX_RX_FE_INT	Level	IRQ_0	IRQ_16	MCSI1 Combined Transmit/Receive/Frame Error Interrupt
MCSI2_TX_RX_FE_INT	Level	IRQ_0	IRQ_17	MCSI2 Combined Transmit/Receive/Frame Error Interrupt
Reserved	–	IRQ_0	IRQ_18	Reserved, keep masked
Reserved	–	IRQ_0	IRQ_19	Reserved, keep masked
USB_CLNT_GENI_INT	Level	IRQ_0	IRQ_20	USB Function General-Purpose Interrupt
1WIRE_INT	Level	IRQ_0	IRQ_21	1-Wire Interface Interrupt
TIMER_32K_INT	Edge	IRQ_0	IRQ_22	32k Timer Interrupt
MMC_INT	Level	IRQ_0	IRQ_23	MMC/SD Interrupt
ULPD_INT	Level	IRQ_0	IRQ_24	Ultra-Low Power Device module Interrupt
RTC_PERIODIC_TIMER	Edge	IRQ_0	IRQ_25	Real-Time Clock Periodic Timer Interrupt
RTC_ALARM	Level	IRQ_0	IRQ_26	Real-Time Clock Alarm Interrupt
Reserved	–	IRQ_0	IRQ_27	
DSPMMU_IRQ	Level	IRQ_0	IRQ_28	DSP MMU Interrupt
USB_FUNC_IRQ_ISO_ON	Level	IRQ_0	IRQ_29	USB Function Isochronous On Interrupt
USB_FUNC_IRQ_NONISO_ON	Level	IRQ_0	IRQ_30	USB Function Non-Isochronous On Interrupt
MCBSP2_RX_OVERFLOW_INT	Edge	IRQ_0	IRQ_31	McBSP2 Receive Overflow Interrupt

PRODUCT PREVIEW

Table 3–74. DSP Level 1 Interrupt Mappings

INTERRUPT	DSP INTERRUPT	DSP IFR/IMR REGISTER BIT	VECTOR LOCATION (BYTE ADDRESS)	PRIORITY	FUNCTION
RESET	–	–	FFF00h	0	DSP Reset Interrupt
NMI	–	–	FFF08h	1	DSP Nonmaskable Interrupt
EMULATOR_TEST	INT2	2	FFF10h	3	DSP Emulator/Test Interrupt
LEVEL2_INTH_FIQ	INT3	3	FFF18h	5	FIQ Interrupt from DSP Level 2 Handler
TC_ABORT	INT4	4	FFF20h	6	Traffic Controller Abort Interrupt
MAILBOX_1	INT5	5	FFF28h	7	MPU-to-DSP Mailbox 1 Interrupt
Reserved	INT6	6	FFF30h	9	Unused, keep masked
GPIO	INT7	7	FFF38h	10	Interrupt for DSP-owned Shared GPIO
TIMER3	INT8	8	FFF40h	11	DSP Timer 3 Interrupt
DMA_CHANNEL_1	INT9	9	FFF48h	9	DSP DMA Channel 1 Interrupt
MPU	INT10	10	FFF50h	13	MPU Interrupt to DSP
Reserved	INT11	11	FFF58h	14	Unused, keep masked
UART	INT12	12	FFF60h	15	UART Interrupt
WDGTIMER	INT13	13	FFF68h	17	DSP Watchdog Timer Interrupt
DMA_CHANNEL_4	INT14	14	FFF70h	18	DSP DMA Channel 4 Interrupt
DMA_CHANNEL_5	INT15	15	FFF78h	21	DSP DMA Channel 5 Interrupt
EMIF	INT16	16	FFF80h	22	Interrupt for DMA EMIF interface to Traffic Controller
LOCAL_BUS	INT17	17	FFF88h	4	Local Bus Interrupt
DMA_CHANNEL_0	INT18	18	FFF90h	8	DSP DMA Channel 0 Interrupt
MAILBOX2	INT19	19	FFF98h	12	MPU-to-DSP Mailbox 2 Interrupt
DMA_CHANNEL_2	INT20	20	FFFA0h	16	DSP DMA Channel 2 Interrupt
DMA_CHANNEL_3	INT21	21	FFFA8h	19	DSP DMA Channel 3 Interrupt
TIMER2	INT22	22	FFFB0h	20	DSP Timer 2 Interrupt
TIMER1	INT23	23	FFFB8h	23	DSP Timer 1 Interrupt

Table 3–75. DSP Level 2 Interrupt Mappings

INTERRUPT	DEFAULT SENSITIVITY	LEVEL 1 MAPPING	LEVEL 2 MAPPING	FUNCTION
MCBSP3_TX	Edge	INT3	IRQ_0	McBSP3 Transmit Interrupt
MCBSP3_RX	Edge	INT3	IRQ_1	McBSP3 Receive Interrupt
MCBSP1_TX	Edge	INT3	IRQ_2	McBSP1 Transmit Interrupt
MCBSP1_RX	Edge	INT3	IRQ_3	McBSP1 Receive Interrupt
UART2	Level	INT3	IRQ_4	UART2 Interrupt
UART1	Level	INT3	IRQ_5	UART1 Interrupt
MCSI1_TX	Level	INT3	IRQ_6	MCSI1 Transmit Interrupt
MCSI1_RX	Level	INT3	IRQ_7	MCSI1 Receive Interrupt
MCSI2_TX	Level	INT3	IRQ_8	MCSI2 Transmit Interrupt
MCSI2_RX	Level	INT3	IRQ_9	MCSI2 Receive Interrupt
MCSI1_FRAME_ERROR_INT	Level	INT3	IRQ_10	MCSI1 Frame Error Interrupt
MCSI2_FRAME_ERROR_INT	Level	INT3	IRQ_11	MCSI2 Frame Error Interrupt
Reserved	–	INT3	IRQ_12	Reserved, keep masked
Reserved	–	INT3	IRQ_13	Reserved, keep masked
Reserved	–	INT3	IRQ_14	Reserved, keep masked
Reserved	–	INT3	IRQ_15	Reserved, keep masked

PRODUCT PREVIEW

4 Documentation Support

Extensive documentation supports all OMAP platform of devices from product announcement through applications development. The following types of documentation are available to support the design and use of the OMAP platform of dual-core processor devices:

- Device-specific data sheets
- Development-support tools
- Hardware and software application reports

A series of DSP textbooks is published by Prentice-Hall and John Wiley & Sons to support digital signal processing research and education. The TMS320 DSP newsletter, *Details on Signal Processing*, is published quarterly and distributed to update TMS320 DSP customers on product information.

Information regarding Texas Instruments (TI) OMAP and DSP products is also available on the Worldwide Web at <http://www.ti.com> uniform resource locator (URL).

4.1 Device and Development-Support Tool Nomenclature

To designate the stages in the product development cycle, TI assigns prefixes to the part numbers of all OMAP devices and support tools. Each commercial OMAP platform member has one of three prefixes: X, P, or null (no prefix). Texas Instruments recommends two of three possible prefix designators for support tools: TMDX and TMDS. These prefixes represent evolutionary stages of product development from engineering prototypes (TMDX) through fully qualified production devices/tools (TMDS).

Device development evolutionary flow:

- X** Experimental device that is not necessarily representative of the final device's electrical specifications and may not use production assembly flow
- P** Prototype device that is not necessarily the final silicon die and may not necessarily meet final electrical specifications
- null** Production version of the silicon die that is fully qualified

Support tool development evolutionary flow:

- TMDX** Development-support product that has not yet completed Texas Instruments internal qualification testing.
- TMDS** Fully qualified development-support product

X and P devices and TMDX development-support tools are shipped against the following disclaimer:

“Developmental products intended for evaluation purposes.”

Production devices and TMDS development-support tools have been characterized fully, and the quality and reliability of the device have been demonstrated fully. TI's standard warranty applies.

5 Electrical Specifications

This section provides the absolute maximum ratings and the recommended operating conditions for the OMAP5910 device.

All electrical and switching characteristics in this data manual are valid over the recommended operating conditions unless otherwise specified.

5.1 Absolute Maximum Ratings

The list of absolute maximum ratings are specified over operating case temperature. Stresses beyond those listed under “absolute maximum ratings” may cause permanent damage to the device. These are stress ratings only, and functional operation of the device at these or any other conditions beyond those indicated under Section 5.2, Recommended Operating Conditions, is not implied. Exposure to absolute-maximum-rated conditions for extended periods may affect device reliability. All supply voltage values (core and I/O) are with respect V_{SS} .

NOTE: The OMAP5910 device adheres to EIA/JESD22-A114 “Electrostatic Discharge (ESD) Sensitivity Testing Human Body Model (HBM)”. Minimum pass level for HBM is ± 2.0 kV.

This section provides the absolute maximum ratings for the OMAP5910 device.

Supply voltage range (core), $CV_{DD}, CV_{DD1/2/3/4/A}$	-0.3 V to 1.8 V
Supply voltage range (I/O), $DV_{DD1/2/3/4/5}$	-0.3 V to 4 V
Input voltage range, V_I (12-MHz and 32-kHz oscillator)	-0.3 V to $CV_{DD} + 0.5$ V
Input voltage range, V_I (standard LVCMOS)	-0.3 V to $DV_{DD} + 0.5$ V
Input voltage range, V_I (fail-safe LVCMOS)	-0.3 V to 4.5 V
Input voltage range, V_I (USB transceivers)	-0.3 V to $DV_{DD} + 0.5$ V
Input voltage range, V_I (I ² C)	-0.3 V to 4.5 V
Output voltage range, V_O (standard LVCMOS)	-0.3 V to $DV_{DD} + 0.5$ V
Output voltage range, V_O (fail-safe LVCMOS)	-0.3 V to 4.5 V
Output voltage range, V_O (USB transceivers)	-0.3 V to $DV_{DD} + 0.5$ V
Output voltage range, V_O (I ² C)	-0.3 V to 4.5 V
Operating temperature range, T_C	-40°C to 85°C
Storage temperature range, T_{stg}	-55°C to 150°C

5.2 Recommended Operating Conditions

		MIN	NOM	MAX	UNIT	
CV _{DD} CV _{DD1/2/3/4/A}	Device supply voltage, core [†]	Deep sleep mode	1	1.1	1.675	V
		Low Power Standby mode [‡]	1.525	1.6	1.675	
DV _{DD1}	Device supply voltage, I/O (Peripheral I/O)	2.5	2.75 or 3.3	3.6	V	
DV _{DD2}	Device supply voltage, I/O (USB transceiver)	3	3.3	3.6	V	
DV _{DD3}	Device supply voltage, I/O (MCSI2, McBSP2, GPIO[9:8])	Low-voltage range [§]	1.65	1.8	1.95	V
		High-voltage range [§]	2.5	2.75 or 3.3	3.6	
DV _{DD4}	Device supply voltage, I/O (SDRAM interface)	Low-voltage range [§]	1.65	1.8	1.95	V
		High-voltage range [§]	2.5	2.75 or 3.3	3.6	
DV _{DD5}	Device supply voltage, I/O (FLASH interface)	Low-voltage range [§]	1.65	1.8	2	V
		High-voltage range [§]	2.5	2.75 or 3.3	3.6	
CV _{DD} –DV _{DD}	Device supply voltage difference [¶]			1.65	V	
DV _{DD} –CV _{DD}	Device supply voltage difference [¶]			2.6	V	
V _{SS}	Supply voltage, GND		0		V	
V _{IH}	High-level input voltage, I/O	Standard LVCMOS	0.7 DV _{DD}	DV _{DD}	V	
		Fail-safe LVCMOS	0.7 DV _{DD}	DV _{DD}		
		USB.DP, DM (mode1)	2	DV _{DD}		
		I ² C	0.7 DV _{DD}	DV _{DD}		
V _{IL}	Low-level input voltage, I/O	Standard LVCMOS	0	0.3 DV _{DD}	V	
		Fail-safe LVCMOS	0	0.3 DV _{DD}		
		USB.DP, DM (mode1)	0	0.8		
		I ² C	0	0.3 DV _{DD}		
V _I	Input voltage	USB.DP, DM (mode 2)	0.8	2.5	V	
		OSC1 and OSC32K pins		CV _{DD}		
V _{ID}	Differential input voltage, I/O	USB.DP, DM (mode 2)	200		mV	
I _{OH}	High-level output current	2-mA drive strength buffers		–2	mA	
		4-mA drive strength buffers		–4		
		8-mA drive strength buffers		–8		
		18.3-mA drive strength buffers		–18.3		
I _{OL}	Low-level output current	2-mA drive strength buffers		2	mA	
		4-mA drive strength buffers		4		
		6-mA drive strength buffers		6		
		8-mA drive strength buffers		8		
		18.3-mA drive strength buffers		18.3		
T _C	Operating case temperature	–40		85	°C	

[†] All core voltage supplies should be tied to the same voltage level (within 0.3 V).

[‡] Low Power Standby is defined as follows: the device is in Deep Sleep mode and LOW_PWR = 1. The device runs from 32kHz clock in this mode.

[§] High and low voltage ranges are selectable via software configuration.

[¶] In systems where the CV_{DDx} and DV_{DDx} power supplies are ramped at generally the same time (within 500ms of one another), there are no specific power sequencing requirements for the supplies. The only sequencing requirement is that the maximum voltage difference between CV_{DD} and DV_{DD} is not exceeded for greater than 500ms. Likewise, if different voltages are used for the separate DV_{DDx} supplies, all DV_{DDx} supplies should ramp up to valid voltage levels within 500ms of one another.

5.3 Electrical Characteristics Over Recommended Operating Case Temperature Range (Unless Otherwise Noted)

PARAMETER		TEST CONDITIONS	MIN	TYP	MAX	UNIT		
V _{OH}	High-level output voltage	Standard LVCMOS	DV _{DD} = 3.3 V, I _{OH} = MAX		0.8 DV _{DD}	V		
		Fail-safe LVCMOS	DV _{DD} = 3.3 V, I _{OH} = MAX		0.8 DV _{DD}			
		USB.DP, DM	I _O = -12 mA		DV _{DD} - 0.5			
V _{OL}	Low-level output voltage	Standard LVCMOS	DV _{DD} = 3.3 V, I _{OH} = MAX		0.22 DV _{DD}	V		
		Fail-safe LVCMOS	DV _{DD} = 3.3 V, I _{OH} = MAX		0.22 DV _{DD}			
		USB.DP, DM	I _O = 12 mA		0.5			
		I ² C	Fast mode at 6-mA load		0.6			
			Fast mode at 3-mA load		0.4			
		Standard mode at 3-mA load		0.4				
I _I	Input current	Fail-safe LVCMOS inputs without internal pullups/pulldowns enabled	V _I = V _I MAX to V _I MIN		-20	20	μA	
		Other Inputs without internal pullups/pulldowns enabled	V _I = V _I MAX to V _I MIN		-1	1		
		Input pins with 20-μA pulldowns enabled	DV _{DD} = MAX, V _I = V _{SS} to V _{DD}		6	20		60
		Input pins with 100-μA pulldowns enabled	DV _{DD} = MAX, V _I = V _{SS} to V _{DD}		30	100		300
		Input pins with 20-μA pullups enabled	CV _{DD} = MAX, V _I = V _{SS} to V _{DD}		-60	-20		-6
		Input pins with 100-μA pullups enabled	DV _{DD} = MAX, V _I = V _{SS} to V _{DD}		-20	-100		-30
I _{OZ}	Input current for outputs in high-impedance				-20	20	μA	
I _{DDC(Q)}	Core voltage supply current, quiescent	Sum of CV _{DDx} currents. (Deep sleep mode with CV _{DD} = 1.6V)		115		μA		
		Sum of CV _{DDx} currents. (Deep sleep mode with CV _{DD} = 1.1V)		50				
I _{DDC(A)}	Core voltage supply current, active	Sum of CV _{DDx} currents (Case 1†).		150		mA		
		Sum of CV _{DDx} currents (Case 2‡).		170		mA		
I _{DDC(PA)}	Core and I/O voltage supply current, active	Sum of CV _{DDx} and DV _{DDx} currents (Case 3§).		45		mA		
		Sum of CV _{DDx} and DV _{DDx} currents (Case 4¶).		6		mA		
C _i	Input capacitance	USB.DP,DM		7		pF		
		All other I/O pins		4				
C _O	Output capacitance	USB.DP,DM		7		pF		
		All other I/O pins		4				

† Case 1: MPU running OS, DSP running GSM Vocoder from internal memory, DSP MMU and all clock domains active, no LCD activity.

‡ Case 2: Same conditions as Case 1 only DSP running from external memory with I-cache enabled.

§ Case 3: Only LCD activity (MPU and DSP idled with clocks off). LCD running 320x240 TFT at 70 Frames per second with frame buffer in internal memory (DPLL at 120MHz).

¶ Case 4: Same as Case 3 only LCD running at 10 Frames per second with DPLL at 6MHz.

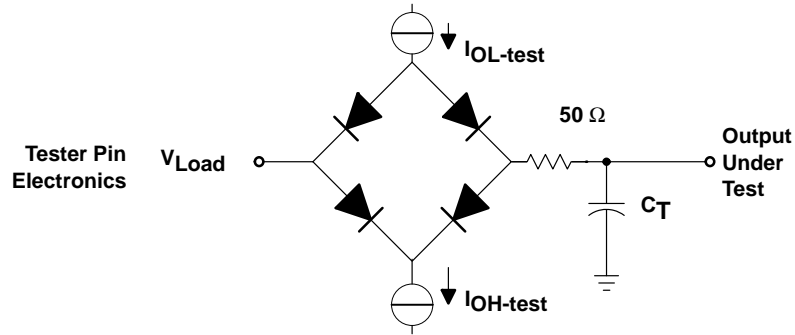

Where: $I_{OL-test} = 5 \text{ mA}$ (all outputs)
 $I_{OH-test} = 300 \mu\text{A}$ (all outputs)
 $V_{Load} = 5 \text{ V}$
 $C_T = 10 \text{ pF}$ maximum and 5 pF minimum for EMIFF (50 pF maximum and 5 pF minimum for EMIFS and all other I/O pads).

Figure 5–1. 3.3-V Test Load Circuit

5.4 Package Thermal Resistance Characteristics

Table 5–1 provides the thermal resistance characteristics for the recommended package types used on the OMAP5910 device.

Table 5–1. Thermal Resistance Characteristics

$R_{\theta JA}$ (°C/W)	$R_{\theta JC}$ (°C/W)	BOARD TYPE†
34.01	7.43	High-K
63.26	7.13	Low-K

† Board types are as defined by JEDEC. Reference JEDEC Standard JESD51–9, Test Boards for Area Array Surface Mount Package Thermal Measurements.

5.5 Timing Parameter Symbology

Timing parameter symbols used in the timing requirements and switching characteristics tables are created in accordance with JEDEC Standard 100. To shorten the symbols, some of the pin names and other related terminology have been abbreviated as follows:

Lowercase subscripts and their meanings:

a	access time
c	cycle time (period)
d	delay time
dis	disable time
en	enable time
f	fall time
h	hold time
r	rise time
su	setup time
t	transition time
v	valid time
w	pulse duration (width)
X	Unknown, changing, or don't care level

Letters and symbols and their meanings:

H	High
L	Low
V	Valid
Z	High impedance

5.6 Clock Specifications

This section provides the timing requirements and switching characteristics for the OMAP5910 system clock signals.

5.6.1 32-kHz Oscillator and Input Clock

The 32.768-kHz clock signal (often abbreviated to 32-kHz) may be supplied by either the on-chip 32-kHz oscillator (requiring an external crystal) or an external CMOS signal. The state of the CLK32K_CTRL pin determines which is used.

The on-chip oscillator requires an external 32.768-kHz crystal connected across the OSC32K_IN and OSC32K_OUT pins. The connection of the required circuit, consisting of the crystal and two load capacitors, is shown in Figure 5–2. The load capacitors, C₁ and C₂, should be chosen such that the equation below is satisfied (recommended values are C₁ = C₂ = 10pF). C_L in the equation is the load specified for the crystal. All discrete components used to implement the oscillator circuit should be placed as close as possible to the associated oscillator pins (OSC32K_IN and OSC32K_OUT) and to the VSS pin closest to the oscillator pins (V12).

NOTE: The 12-MHz oscillator is powered by the CVDD supply. If an external clock source is used instead of using the on-chip oscillator, care must be taken that the voltage level driven onto the OSC1_IN and OSC1_OUT pins is no greater than the CVDD voltage level.

$$C_L = \frac{C_1 C_2}{(C_1 + C_2)}$$

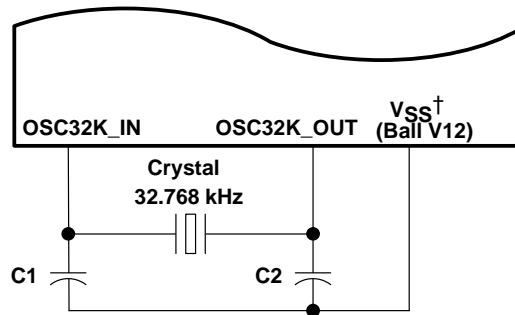

† Do not connect Vss ball V12 to the common board ground but only to the oscillator circuit as shown.

Figure 5–2. 32-kHz Oscillator External Crystal

Table 5–2 and Table 5–3 show the switching characteristics of the 32-kHz oscillator and the input requirements of the 32-kHz clock input.

Table 5–2. 32-kHz Oscillator Switching Characteristics

PARAMETER	MIN	TYP	MAX	UNIT
I _{DDA} , active current consumption		4		μA
Oscillation frequency		32.768		kHz

Table 5–3. 32-kHz Input Clock Timing Requirements

NO.		MIN	NOM	MAX	UNIT
CK1	t_{cyc} Frequency		32.768		kHz
CK2	t_f Fall time			25	ns
CK3	t_r Rise time			25	ns
CK4	Duty cycle (high-to-low ratio)	30%		70%	%
CK5	Frequency stability	-70		70	ppm

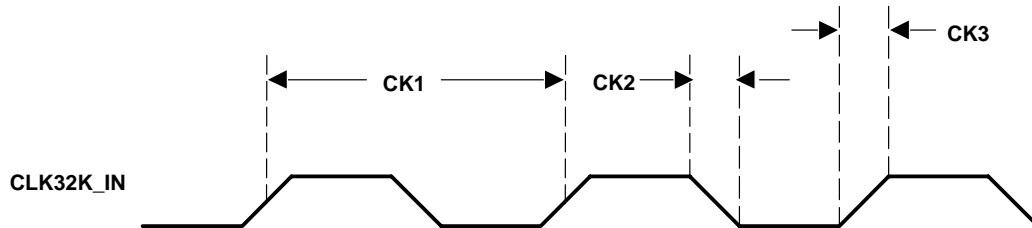

Figure 5–3. 32-kHz Input Clock

5.6.2 12-MHz Oscillator and Input Clock

The internal 12-MHz system oscillator is enabled following a device reset. The oscillator requires an external crystal to be connected across the OSC1_IN and OSC1_OUT pins. If the internal oscillator is not used (configured in software), an external clock source must be applied to the OSC1_IN pin and the OSC1_OUT pin should be left unconnected. Since the internal oscillator can be used as a clock source to the OMAP DPLL, the 12-MHz crystal oscillation frequency can be multiplied to generate the DSP clock, MPU clock, Traffic Controller clock.

The crystal should be in fundamental-mode operation, and parallel resonant, with a maximum effective series resistance of 30 Ω maximum and power dissipation of 1 mW. The connection of the required circuit, consisting of the crystal and two load capacitors, is shown in Figure 5–4. The load capacitors, C_1 and C_2 , should be chosen such that the equation below is satisfied (recommended values are $C_1 = C_2 = 10\text{pF}$). C_L in the equation is the load specified for the crystal. All discrete components used to implement the oscillator circuit should be placed as close as possible to the associated oscillator pins (OSC1_IN and OSC1_OUT) and to the VSS pins closest to the oscillator pins (AA1 and Y3).

NOTE: The 12-MHz oscillator is powered by the CVDD supply. If an external clock source is used instead of using the on-chip oscillator, care must be taken that the voltage level driven onto the OSC1_IN and OSC1_OUT pins is no greater than the CVDD voltage level.

$$C_L = \frac{C_1 C_2}{(C_1 + C_2)}$$

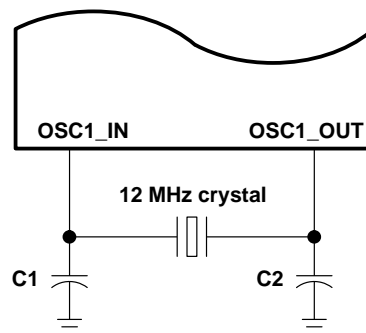

Figure 5–4. Internal System Oscillator External Crystal

If USB Host functionality is used, it is recommended that a very low PPM crystal (≤ 50 ppm) is used for the 12-MHz oscillator circuit.

Table 5–4 shows the switching characteristics of the 12-MHz oscillator.

Table 5–4. 12-MHz Oscillator Switching Characteristics

PARAMETER	MIN	TYP	MAX	UNIT
I _{DDA} , active current consumption		350		μA
Oscillation frequency		12		MHz

5.6.3 Internal Clock Speed Limitations

Table 5–5 provides a summary of the maximum frequencies that each clock domain may be configured to run on the OMAP5910 device

Table 5–5. Internal Clock Speed Limitations

CLOCK	MAX OPERATING FREQUENCY	UNIT
MPU (CLKM1)	150	MHz
DSP (CLKM2)	150	MHz
TC (CLKM3)	75	MHz
DPLL1	150	MHz

All clock domains must be derived from the same DPLL1 frequency setting; therefore, the following conditions must be satisfied where ‘m’, ‘n’, and ‘o’ are each equal to either 1, 2, 4 or 8:

- MPU frequency = (DPLL1 clock frequency) / m
- DSP frequency = (DPLL1 clock frequency) / n
- TC frequency = (DPLL1 clock frequency) / o

For example, the following configuration is valid:

- MPU/DSP/TC = 150 MHz/150 MHz/75 MHz

5.7 Reset Timings

This section provides the timing requirements for the OMAP5910 hardware reset signals.

5.7.1 OMAP5910 Device Reset

The $\overline{\text{PWRON_RESET}}$ signal is the active-low asynchronous reset input responsible for the reset of the entire OMAP5910 device. When using an external crystal to supply the 32-kHz system clock, $\overline{\text{PWRON_RESET}}$ must be asserted low a minimum of two 32-kHz clock cycles longer than the worst-case start-up time of the 32-kHz oscillator after stable power supplies (see Figure 5–5). If an external CMOS input signal is used to source 32 kHz, $\overline{\text{PWRON_RESET}}$ must be asserted low a minimum of two 32-kHz clock cycles after stable power supplies.

Table 5–6. OMAP5910 Device Reset Timing Requirements †

NO.		MIN	MAX	UNIT
RS1	$t_w(\text{PWRON_RST})$ Pulse duration, $\overline{\text{PWRON_RESET}}$ low	$N + 2P$		ns

† P = period of 32-kHz clock, N = worst-case 32-kHz oscillator start-up time after stable power

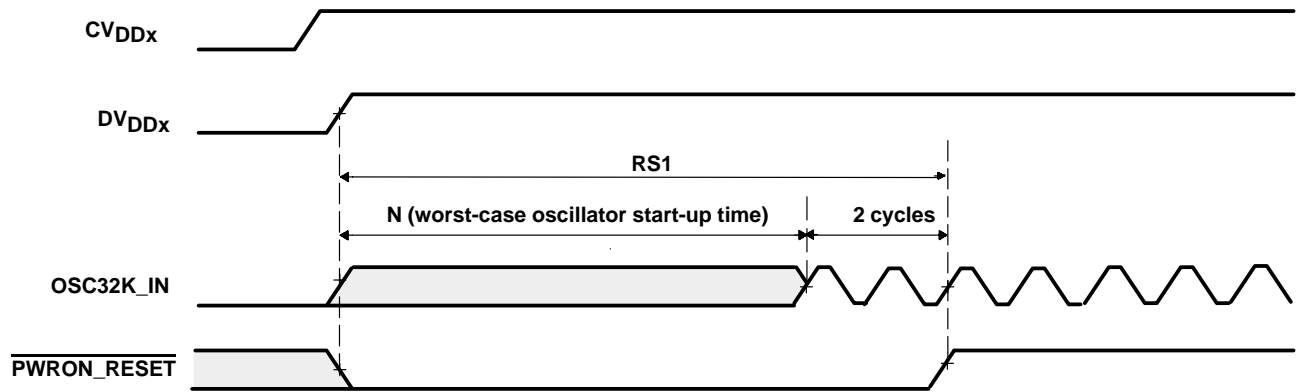

Figure 5–5. Device Reset Timings

PRODUCT PREVIEW

5.7.2 OMAP5910 MPU Core Reset

The $\overline{\text{MPU_RST}}$ signal is the active-low asynchronous input responsible for the reset of the OMAP5910 MPU core. Stable power supplies are assumed prior to $\overline{\text{MPU_RST}}$ assertion.

Table 5–7. $\overline{\text{MPU_RST}}$ Timing Requirements

NO.		MIN	MAX	UNIT
M3	$t_w(\overline{\text{MPU_RST}})$ Pulse duration, $\overline{\text{MPU_RST}}$ low	100		ns

Table 5–8. $\overline{\text{MPU_RST}}$ Switching Characteristics

NO.	PARAMETER	MIN	MAX	UNIT
M1	$t_d(\overline{\text{MPUL}}\text{--}\overline{\text{RSTL}})$ Delay time, $\overline{\text{MPU_RST}}$ low to $\overline{\text{RST_OUT}}$ low	TBD	TBD	μs
M2	$t_d(\overline{\text{MPUH}}\text{--}\overline{\text{RSTH}})$ Delay time, $\overline{\text{MPU_RST}}$ high to $\overline{\text{RST_OUT}}$ high	TBD	TBD	μs

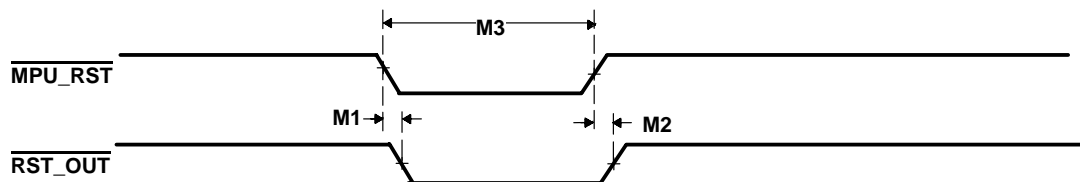

Figure 5–6. MPU Core Reset Timings

PRODUCT PREVIEW

5.8 External Memory Interface Timing

5.8.1 EMIFS/Flash Interface Timing

Table 5–9 and Table 5–10 assume testing over recommended operating conditions (see Figure 5–7 through Figure 5–11).

Table 5–9. EMIFS/Flash Interface Timing Requirements

NO.			DVDD5 = 1.8 V Nominal		DVDD5 = 2.75 V Nominal		DVDD5 = 3.3 V Nominal		UNIT
			MIN	MAX	MIN	MAX	MIN	MAX	
F6	$t_{su}(DV-CLKH)$	Setup time, read data valid before FLASH.CLK high	Async modes (RT = 0)†		7	7	7	7	ns
			Sync Modes (RT = 1)†		2	2	2	2	ns
F7	$t_h(CLKH-RDV)$	Hold time, read data valid after FLASH.CLK high	Async modes (RT = 0)†		0	0	0	0	ns
			Sync Modes (RT = 1)†		2	2	2	2	ns
F10	$t_{su}(RDY-CLKH)$	Setup time, FLASH.RDY valid before FLASH.CLK high	Async modes (RT = 0)†		7	7	7	7	ns
			Sync Modes (RT = 1)†		2	2	2	2	ns
F11	$t_h(CLKH-RDY)$	Hold time, FLASH.RDY valid after FLASH.CLK high	Async modes (RT = 0)†		0	0	0	0	ns
			Sync Modes (RT = 1)†		2	2	2	2	ns

† When the RT field in the EMIFS configuration register is set, input data is retimed to the external FLASH.CLK signal. RT=1 setting is only valid in synchronous modes (protocols 1 and 2).

Table 5–10. EMIFS/Flash Interface Switching Characteristics

NO.	PARAMETER		DV _{DD5} = 1.8 V Nominal		DV _{DD5} = 2.75 V Nominal		DV _{DD5} = 3.3 V Nominal		UNIT		
			MIN	MAX	MIN	MAX	MIN	MAX			
F1	t _d (CLKH–CSV)	Delay time, FLASH.CLK high to FLASH.CSx transition	async modes	1	16	1	15	1	14	ns	
			sync modes	–1	8	–1	7.5	–1	7.5		
F2	t _d (CLKH–BEV)	Delay time, FLASH.CLK high to FLASH.BEX valid	async modes		16		15		14	ns	
			sync modes		8		7.5		7.5		
F3	t _d (CLKH–BEIV)	Delay time, FLASH.CLK high to FLASH.BEX invalid	async modes	1		1		1		ns	
			sync modes	–1		–1		–1			
F4	t _d (CLKH–AV)	Delay time, FLASH.CLK high to address valid	async modes		16		15		14	ns	
			sync modes		8		7.5		7.5		
F5	t _d (CLKH–AIV)	Delay time, FLASH.CLK high to address invalid	async modes	1		1		1		ns	
			sync modes	–1		–1		–1			
F8	t _d (CLKH–ADV)	Delay time, FLASH.CLK high to FLASH.ADV transition	async modes	1	16	1	15	1	14	ns	
			sync modes	–1	8	–1	7.5	–1	7.5		
F9	t _d (CLKH–OEV)	Delay time, FLASH.CLK high to FLASH.OE transition	async modes	1	16	1	15	1	14	ns	
			sync modes	–1	8	–1	7.5	–1	7.5		
F12	t _d (CLKH–WEV)	Delay time, FLASH.CLK high to FLASH.WE transition		1	16		1	15	1	14	ns
F13	t _d (CLKH–WDV)	Delay time, FLASH.CLK high to write data valid†			16			15		14	ns
F14	t _d (CLKH–WDIV)	Delay time, FLASH.CLK high to write data invalid†		1			1			1	ns
F15	t _d (CLKH–DHZ)	Delay time, FLASH.CLK high to data bus high-impedance†			16			15		14	ns
F16	t _d (CLKH–DLZ)	Delay time, FLASH.CLK high to data bus driven†		1			1			1	ns
F17	t _d (CLKH–BAAV)†	Delay time, FLASH.CLK high to FLASH.BAA transition‡	–1 + 0.5P	8 + 0.5P	–1 + 0.5P	7.5 + 0.5P	–1 + 0.5P	7.5 + 0.5P			ns

† Data is referenced to the internal FLASH.CLK

‡ P = period of undivided Traffic Controller clock regardless of FLASH.CLK divider configuration

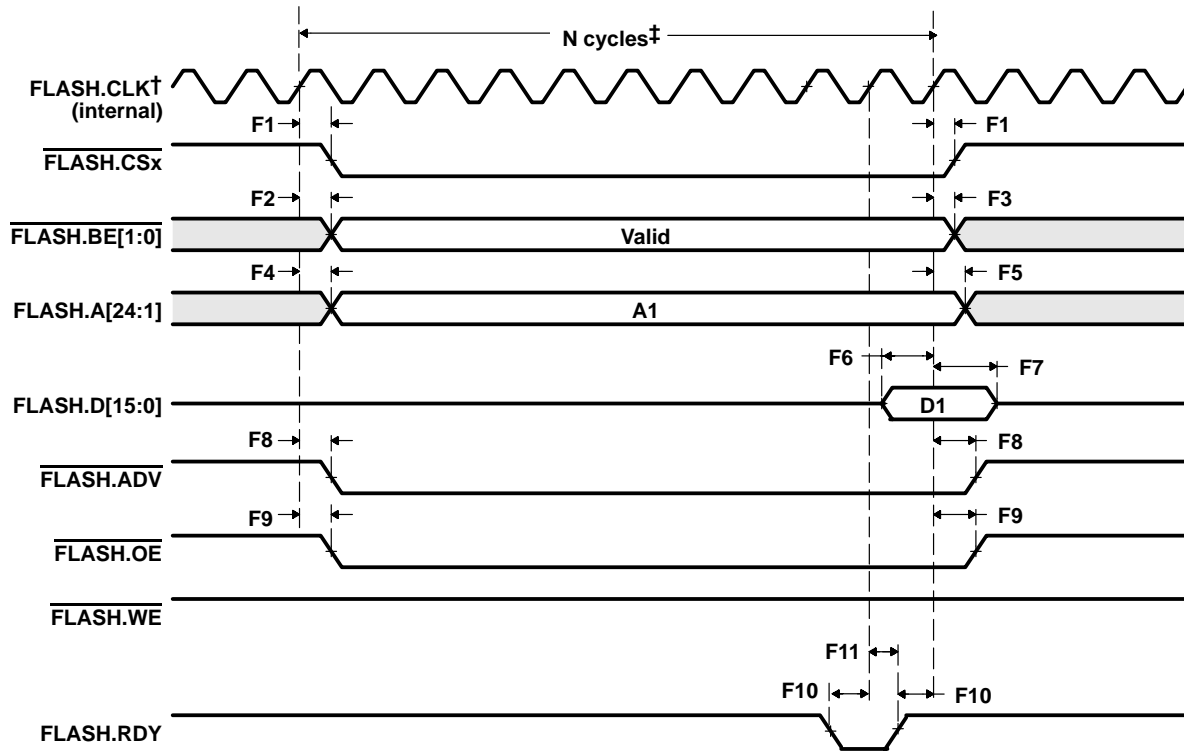

† FLASH.CLK is not driven during this mode of operation. The signal shown represents the internal FLASH.CLK signal given as a reference to express relative timings.

‡ Number of cycles is configurable via EMIFS setup registers.

Figure 5–7. Asynchronous Memory Read Timing

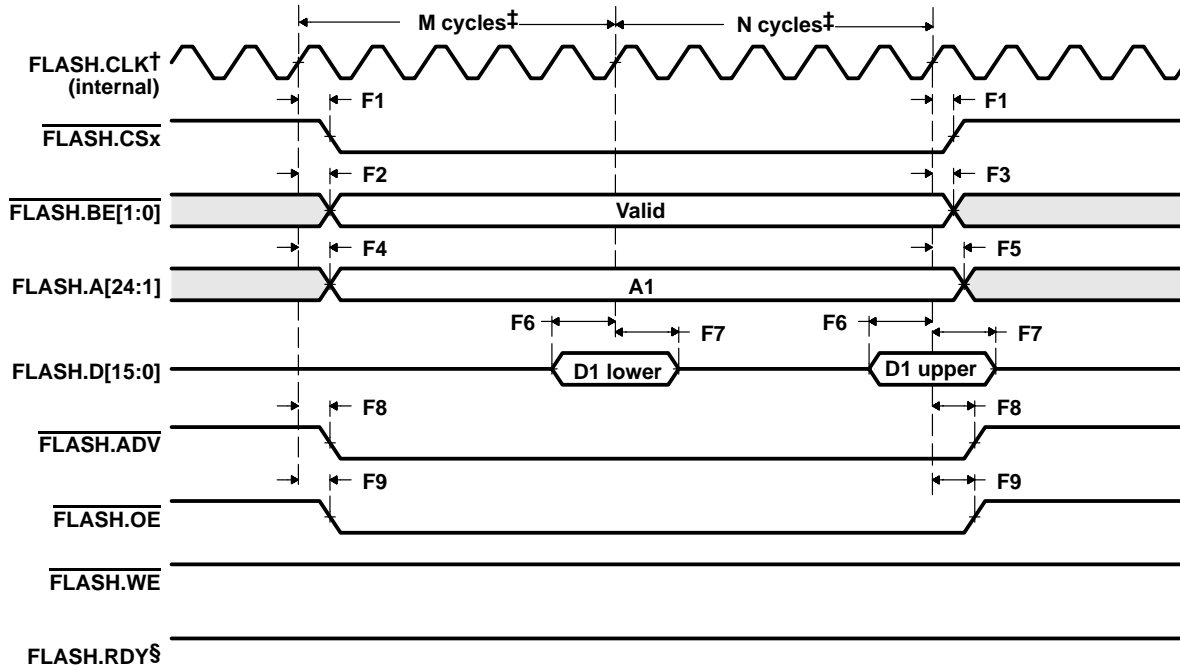

† FLASH.CLK is not driven during this mode of operation. The signal shown represents the internal FLASH.CLK signal given as a reference to express relative timings.

‡ Number of cycles is configurable via EMIFS setup registers.

§ Although shown as always high in this timing diagram, FLASH.RDY may be used to insert wait-states at any time during the cycle similar to the functionality shown in Figure 5–7 and Figure 5–10 and with the same setup and hold times to the clock.

Figure 5–8. Asynchronous 32-Bit Read

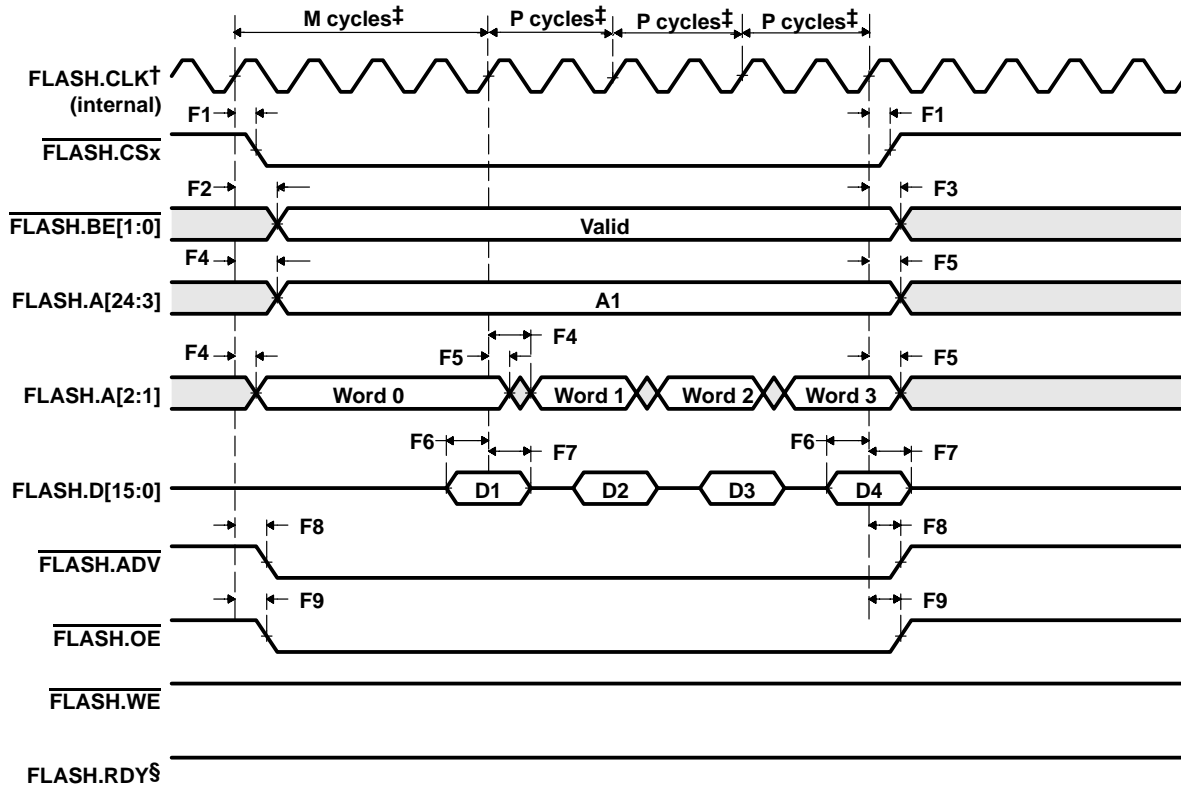

† FLASH.CLK is not driven during this mode of operation. The signal shown represents the internal FLASH.CLK signal given as a reference to express relative timings.
 ‡ Number of cycles is configurable via EMIFS setup registers.
 § Although shown as always high in this timing diagram, FLASH.RDY may be used to insert wait-states at any time during the cycle similar to the functionality shown in Figure 5–7 and Figure 5–10 and with the same setup and hold times to the clock.

Figure 5–9. Asynchronous Read – Page Mode ROM

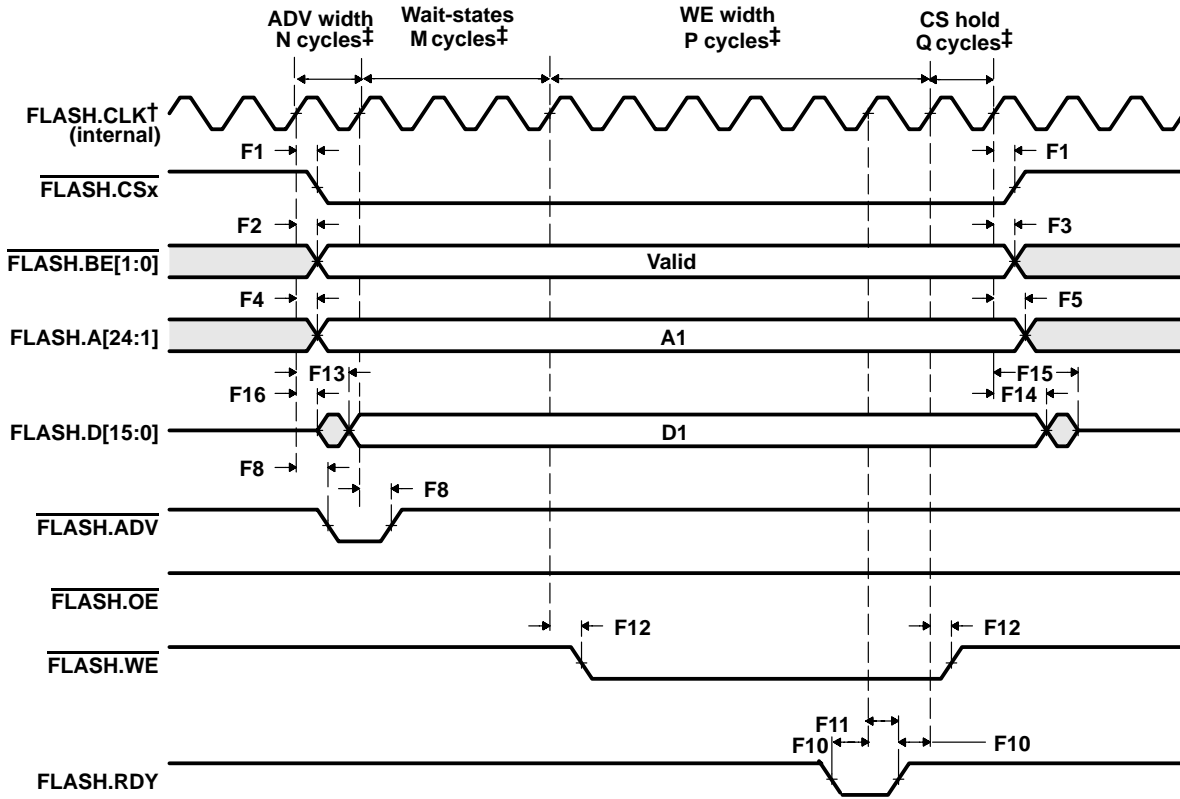

† FLASH.CLK is not driven during this mode of operation. The signal shown represents the internal FLASH.CLK signal given as a reference to express relative timings.

‡ Number of cycles is configurable via EMIFS setup registers.

Figure 5–10. Asynchronous Memory Write Timing

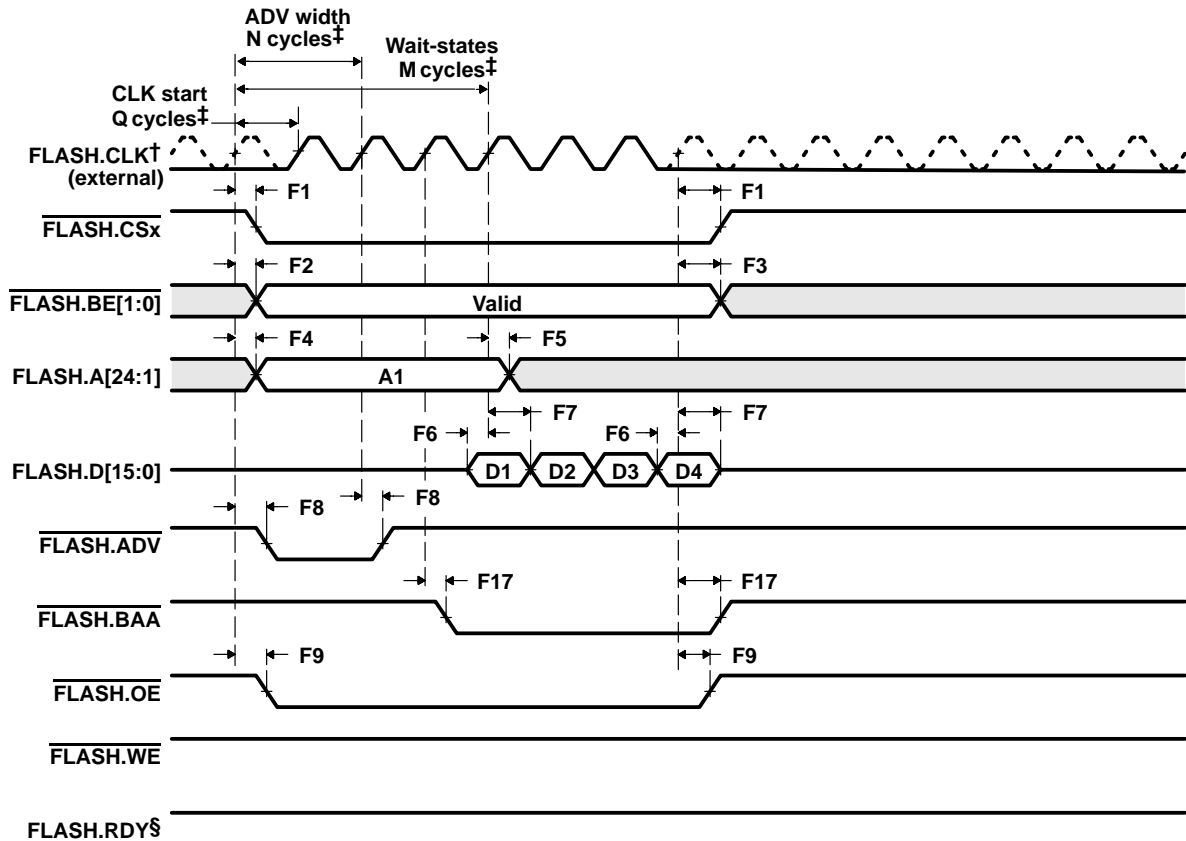

† FLASH.CLK is only driven during the active portion of the cycle. For reference, the dashed line shows FLASH.CLK as if it were continuous.

‡ Number of cycles is configurable via EMIFS setup registers.

§ Although shown as always high in this timing diagram, FLASH.RDY may be used to insert wait-states at any time during the cycle similar to the functionality shown in Figure 5–7 and Figure 5–10 and with the same setup and hold times to the clock.

Figure 5–11. Synchronous Burst Read

5.8.2 EMIFF/SDRAM Interface Timing

Table 5–11 and Table 5–12 assume testing over recommended operating conditions (see Figure 5–12 through Figure 5–17).

Table 5–11. EMIFF/SDRAM Interface Timing Requirements

NO.			DV _{DD4} = 1.8 V Nominal		DV _{DD4} = 2.75 V Nominal		DV _{DD4} = 3.3 V Nominal		UNIT
			MIN	MAX	MIN	MAX	MIN	MAX	
SD7	t _{su} (DV-CLKH)	Setup time, read data valid before SDRAM.CLK high	2		2		2		ns
SD8	t _h (CLKH-DV)	Hold time, read data valid after SDRAM.CLK high	1		1		1		ns

Table 5–12. EMIFF/SDRAM Interface Switching Characteristics

NO.	PARAMETER		DV _{DD4} = 1.8 V Nominal		DV _{DD4} = 2.75 V Nominal		DV _{DD4} = 3.3 V Nominal		UNIT
			MIN	MAX	MIN	MAX	MIN	MAX	
SD1	t _c (CLK)	Cycle time, SDRAM.CLK	13		13		13		ns
SD2	t _w (CLK)	Pulse duration, SDRAM.CLK high/low	2.5		2.5		2.5		ns
SD3	t _d (CLKH-DQM _V)	Delay time, SDRAM.CLK high to SDRAM.DQM _x valid	2	8	2	8	2	8	ns
SD4	t _d (CLKH-DQM _I)	Delay time, SDRAM.CLK high to SDRAM.DQM _x invalid	2	8	2	8	2	8	ns
SD5	t _d (CLKH-AV)	Delay time, SDRAM.CLK high to SDRAM.A[12:0] address valid	2	8	2	8	2	8	ns
SD6	t _d (CLKH-AIV)	Delay time, SDRAM.CLK high to SDRAM.A[12:0] address invalid	2	8	2	8	2	8	ns
SD9	t _d (CLKH-SDCASL)	Delay time, SDRAM.CLK high to SDRAM.CAS low	2	8	2	8	2	8	ns
SD10	t _d (CLKH-SDCASH)	Delay time, SDRAM.CLK high to SDRAM.CAS high	2	8	2	8	2	8	ns
SD11	t _d (CLKH-DV)	Delay time, SDRAM.CLK high to SDRAM.D[15:0] data valid	2	8	2	8	2	8	ns
SD12	t _d (CLKH-DIV)	Delay time, SDRAM.CLK high to SDRAM.D[15:0] data invalid	2	8	2	8	2	8	ns
SD13	t _d (CLKH-SDWEL)	Delay time, SDRAM.CLK high to SDRAM.WE low	2	8	2	8	2	8	ns
SD14	t _d (CLKH-SDWEH)	Delay time, SDRAM.CLK high to SDRAM.WE high	2	8	2	8	2	8	ns
SD15	t _d (CLKH-BAV)	Delay time, SDRAM.CLK high to SDRAM.BA[1:0] valid	2	8	2	8	2	8	ns
SD16	t _d (CLKH-BAIV)	Delay time, SDRAM.CLK high to SDRAM.BA[1:0] invalid	2	8	2	8	2	8	ns
SD17	t _d (CLKH-RASL)	Delay time, SDRAM.CLK high to SDRAM.RAS low	2	8	2	8	2	8	ns
SD18	t _d (CLKH-RASH)	Delay time, SDRAM.CLK high to SDRAM.RAS high	2	8	2	8	2	8	ns

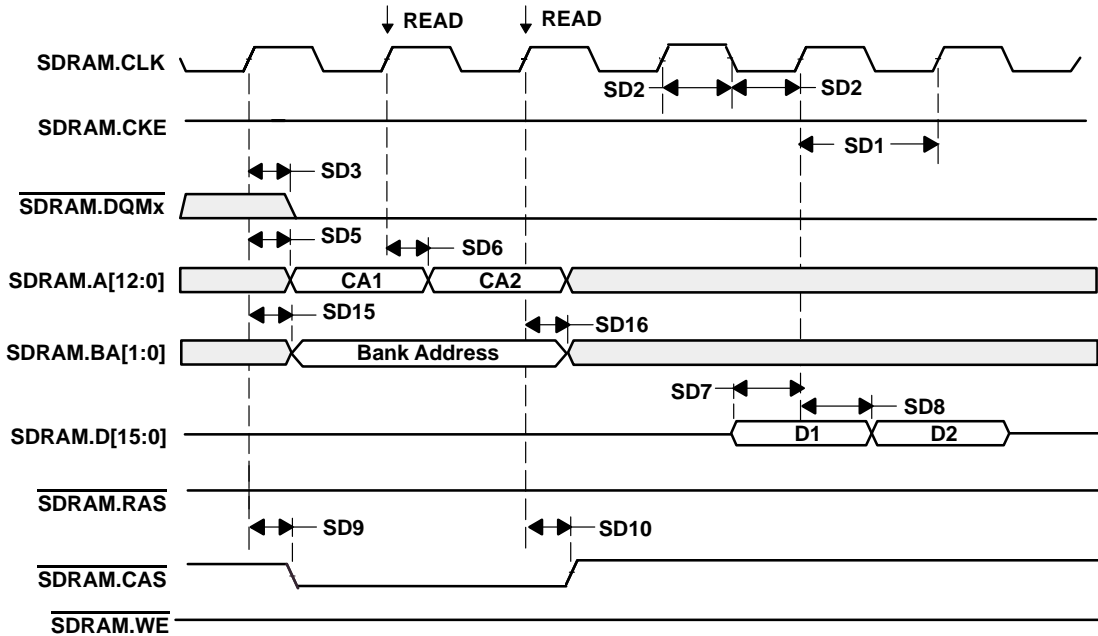

Figure 5–12. Two SDRAM RD (Read) Commands (Active Row)

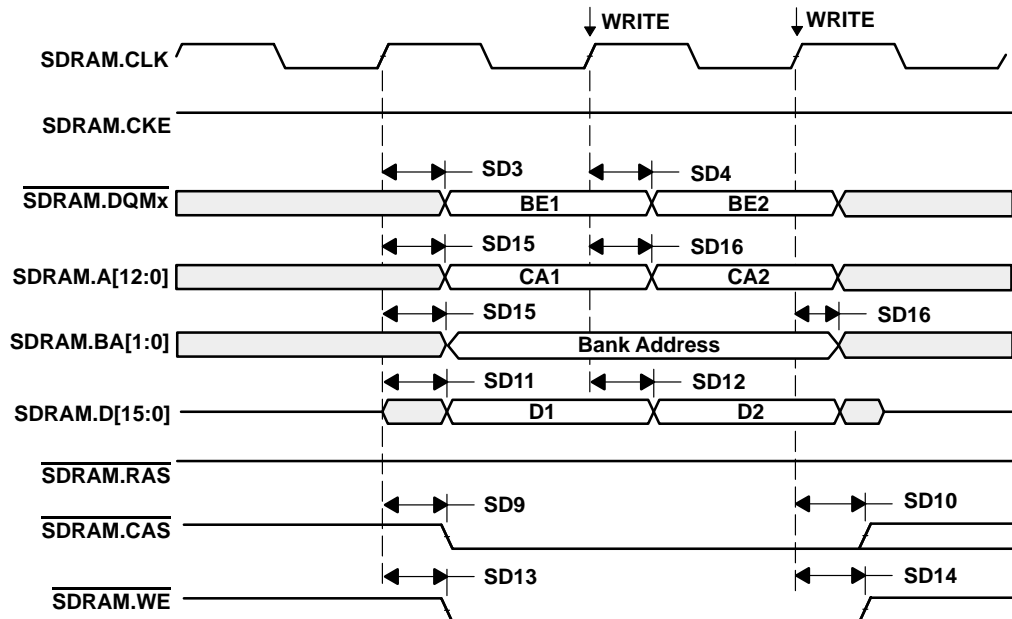

Figure 5–13. Two SDRAM WRT (Write) Commands (Active Row)

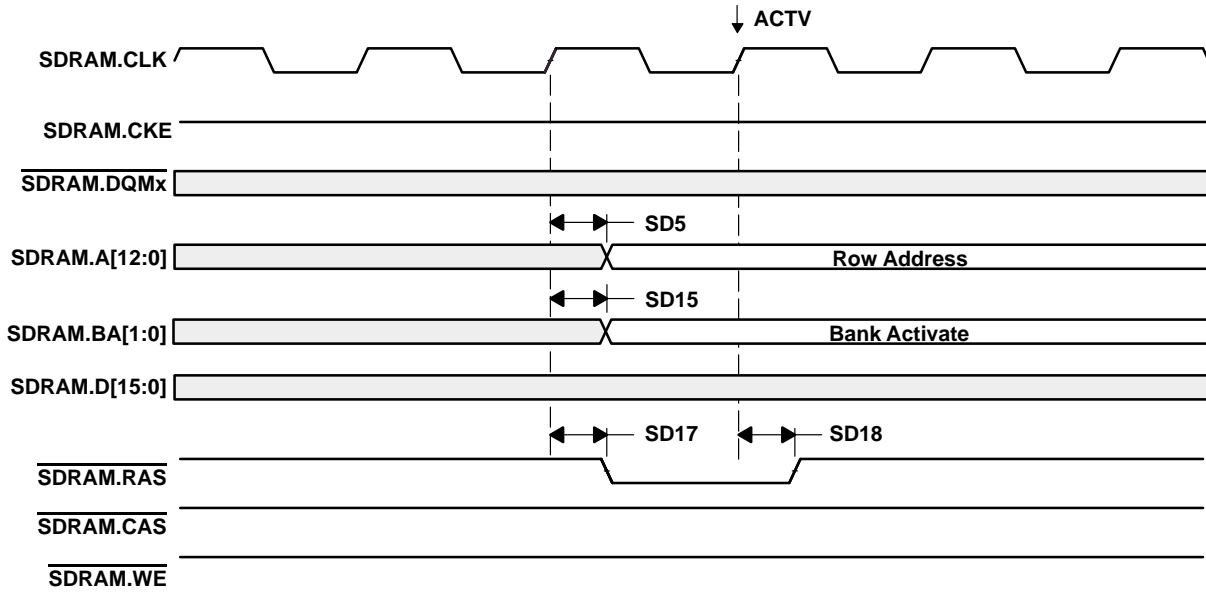

Figure 5–14. SDRAM ACTV (Activate Row) Command

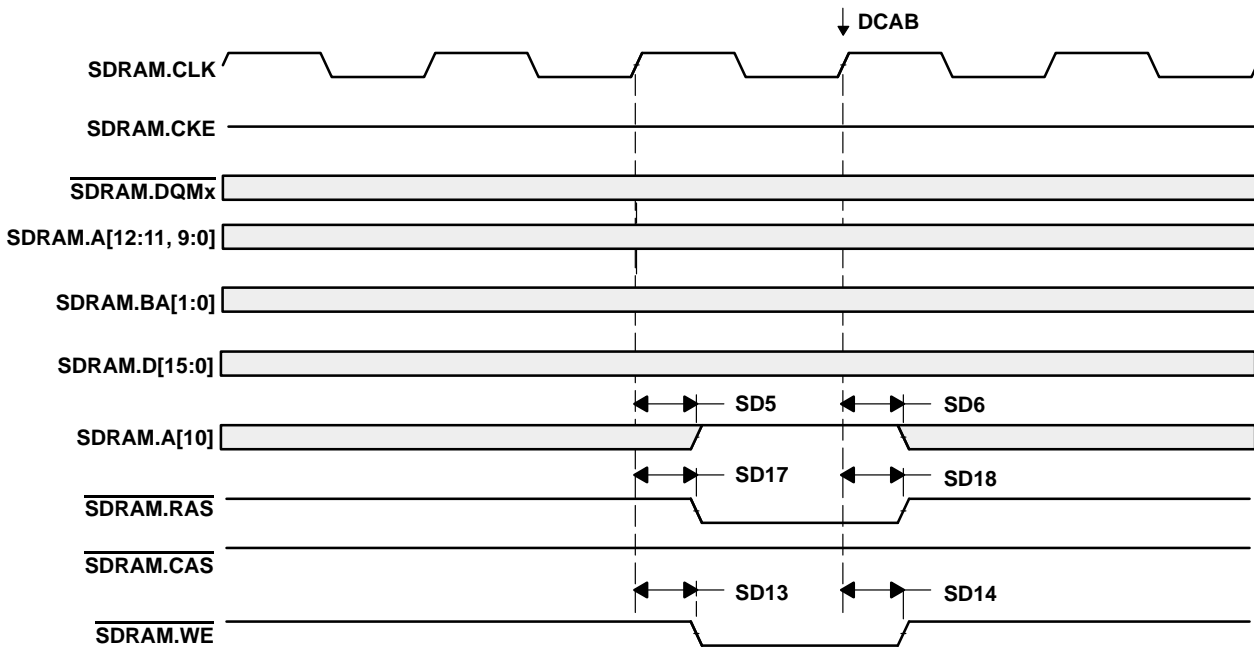

Figure 5–15. SDRAM DCAB (Precharge/Deactivate Row) Command

PRODUCT PREVIEW

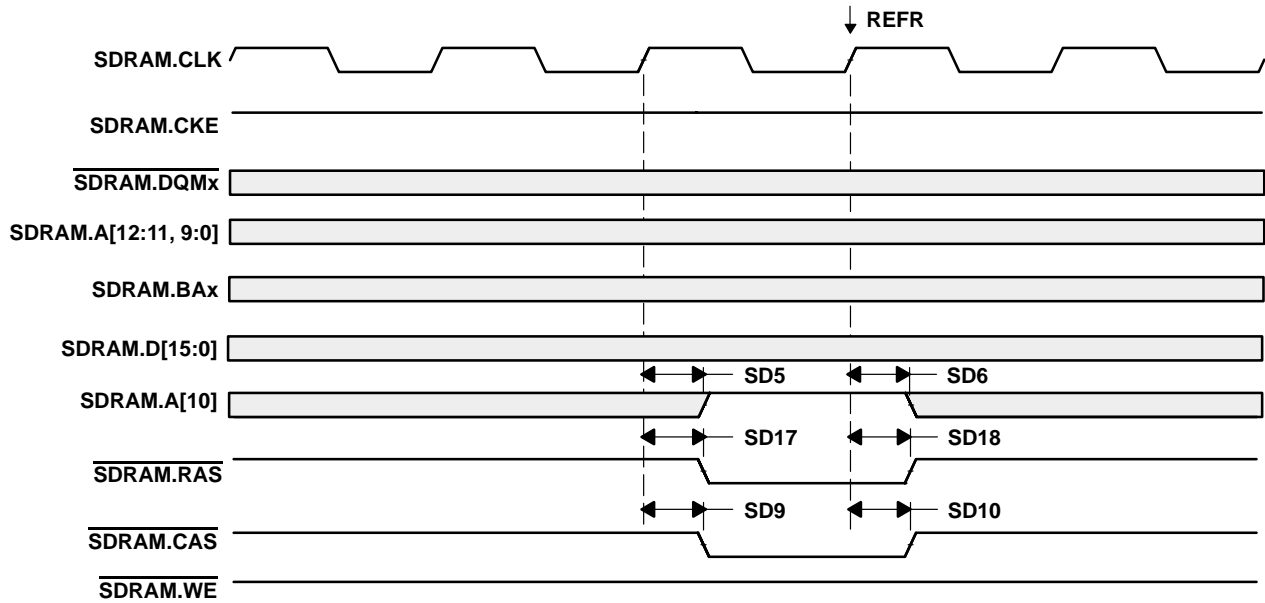

Figure 5–16. SDRAM REFR (Refresh) Command

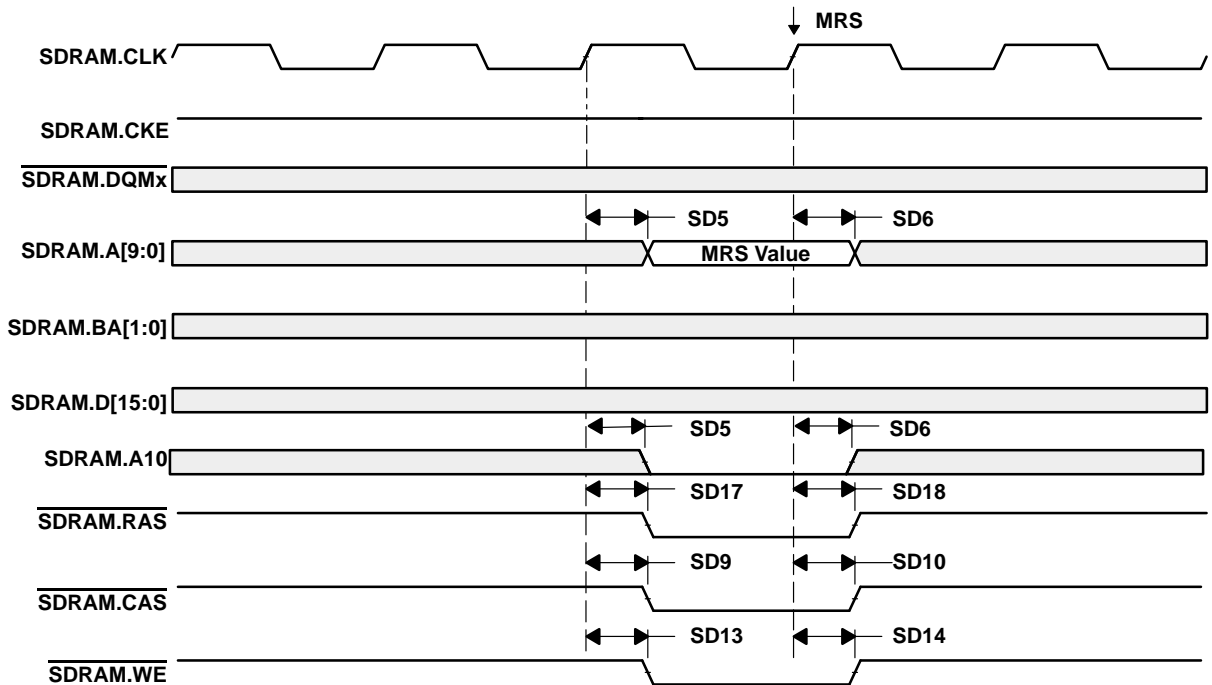

Figure 5–17. SDRAM MRS (Mode Register Set) Command

5.9 Multichannel Buffered Serial Port (McBSP) Timings

5.9.1 McBSP Transmit and Receive Timings

Table 5–13 and Table 5–14 assume testing over recommended operating conditions (see Figure 5–18 and Figure 5–19). In Table 5–13 and Table 5–14, “ext” indicates that the device pin is configured as an input (slave) driven by an external device and “int” indicates that the pin is configured as an output (master).

Table 5–13. McBSP Timing Requirements†‡

NO.				MIN	MAX	UNIT
M11	$t_c(\text{CKRX})$	Cycle time, CLKR/X	CLKR/X ext	2P		ns
M12	$t_w(\text{CKRX})$	Pulse duration, CLKR/X high or CLKR/X low	CLKR/X ext	0.45P		ns
M13	$t_r(\text{CKRX})$	Rise time, CLKR/X	CLKR/X ext		6	ns
M14	$t_f(\text{CKRX})$	Fall time, CLKR/X	CLKR/X ext		6	ns
M15	$t_{su}(\text{FRH-CKRL})$	Setup time, external receiver frame sync (FSR/X) high before CLKR/X low§	McBSP1 (FSX)	CLKX int§	17	ns
				CLKX ext§	21	
			McBSP2 (FSR)	CLKR int	17	ns
				CLKR ext	5	
			McBSP3 (FSX)	CLKX int§	16	ns
				CLKX ext§	10	
M16	$t_h(\text{CKRL-FRH})$	Hold time, external receiver frame sync (FSR/X) high after CLKR/X low§	McBSP1 (FSX)	CLKX int§	2	ns
				CLKX ext§	11	
			McBSP2 (FSR)	CLKR int	2	ns
				CLKR ext	2	
			McBSP3 (FSX)	CLKX int§	9	ns
				CLKX ext§	9	
M17	$t_{su}(\text{DRV-CKRL})$	Setup time, DR valid before CLKR/X low§	McBSP1	CLKX int§	14	ns
				CLKX ext§	2	
			McBSP2	CLKR int	15	ns
				CLKR ext	2	
			McBSP3	CLKX int§	13	ns
				CLKX ext§	7	
M18	$t_h(\text{CKRL-DRV})$	Hold time, DR valid after CLKR/X low§	McBSP1	CLKX int§	2	ns
				CLKX ext§	2	
			McBSP2	CLKR int	2	ns
				CLKR ext	2	
			McBSP3	CLKX int§	2	ns
				CLKX ext§	2	
M19	$t_{su}(\text{FXH-CKXL})$	Setup time, external FSX high before CLKX low	McBSP1	CLKX int	20	ns
				CLKX ext	17	
			McBSP2	CLKX int	19	ns
				CLKX ext	18	
			McBSP3	CLKX int	19	ns
				CLKX ext	18	
M20	$t_h(\text{CKXL-FXH})$	Hold time, external FSX high after CLKX low	McBSP1	CLKX int	2	ns
				CLKX ext	7	
			McBSP2	CLKX int	2	ns
				CLKX ext	2	
			McBSP3	CLKX int	2	ns
				CLKX ext	2	

† Polarity bits CLKRP = CLKXP = FSRP = FSXP = 0. If the polarity of any of the signals is inverted, then the timing references of that signal are also inverted.

‡ P = 1/(12 MHz) for McBSP 1 and 3, or 1/(ARMPER_CK clock frequency) in nanoseconds (ns) for McBSP 2.

§ For McBSP1 and McBSP3, the receiver clock and frame sync inputs are driven by FSX and CLKX via internal loopback connections enabled via software configuration.

Table 5–14. McBSP Switching Characteristics†‡§

NO.	PARAMETER			MIN	MAX	UNIT	
M1	$t_c(\text{CKRX})$	Cycle time, CLKR/X	CLKR/X int	2P		ns	
M2	$t_w(\text{CKRXH})$	Pulse duration, CLKR/X high	CLKR/X int	0.45D	0.55D	ns	
M3	$t_w(\text{CKRXL})$	Pulse duration, CLKR/X low	CLKR/X int	0.45C	0.55C	ns	
M4	$t_d(\text{CKRH-FRV})$	Delay time, CLKR high to internal FSR valid	McBSP2	CLKR int	-1	9	ns
				CLKR ext	-2	16	ns
M5	$t_d(\text{CKXH-FXV})$	Delay time, CLKX high to internal FSX valid	McBSP1	CLKX int	-2	9	ns
				CLKX ext	5	26	
			McBSP2	CLKX int	0	3	ns
				CLKX ext	5	16	
			McBSP3	CLKX int	-1	6	ns
				CLKX ext	5	25	
M7	$t_d(\text{CKXH-DXV})$	Delay time, CLKX high to DX valid. This applies to all bits except the first bit transmitted when in Data Delay 0 (XDATDLY=00b) mode.	McBSP1	CLKX int	-1	5	ns
				CLKX ext	5	27	
			McBSP2	CLKX int	1	7	ns
				CLKX ext	6	18	
			McBSP3	CLKX int	-1	7	ns
				CLKX ext	2	11	
M9	$t_d(\text{FXH-DXV})$	Delay time, FSX high to DX valid¶ Only applies to first bit transmitted when in Data Delay 0 (XDATDLY=00b) mode.	McBSP1	FSX int		19	ns
				FSX ext		17	
			McBSP2	FSX int		20	ns
				FSX ext		18	
			McBSP3	FSX int		7	ns
				FSX ext		18	

† Polarity bits CLKRP = CLKXP = FSRP = FSXP = 0. If the polarity of any of the signals is inverted, then the timing references of that signal are also inverted.

‡ P = 1/(12 MHz) for McBSP 1 and 3, or 1/(ARMPER_CK clock frequency) in ns for McBSP 2.

§ T=CLKRX period = (1 + CLKGDV) * P

C=CLKRX low pulse width = T/2 when CLKGDV is odd or zero and = (CLKGDV/2) * P when CLKGDV is even

D=CLKRX high pulse width = T/2 when CLKGDV is odd or zero and = (CLKGDV/2 + 1) * P when CLKGDV is even

¶ Only DXENA=0 is supported for all OMAP5910 McBSPs.

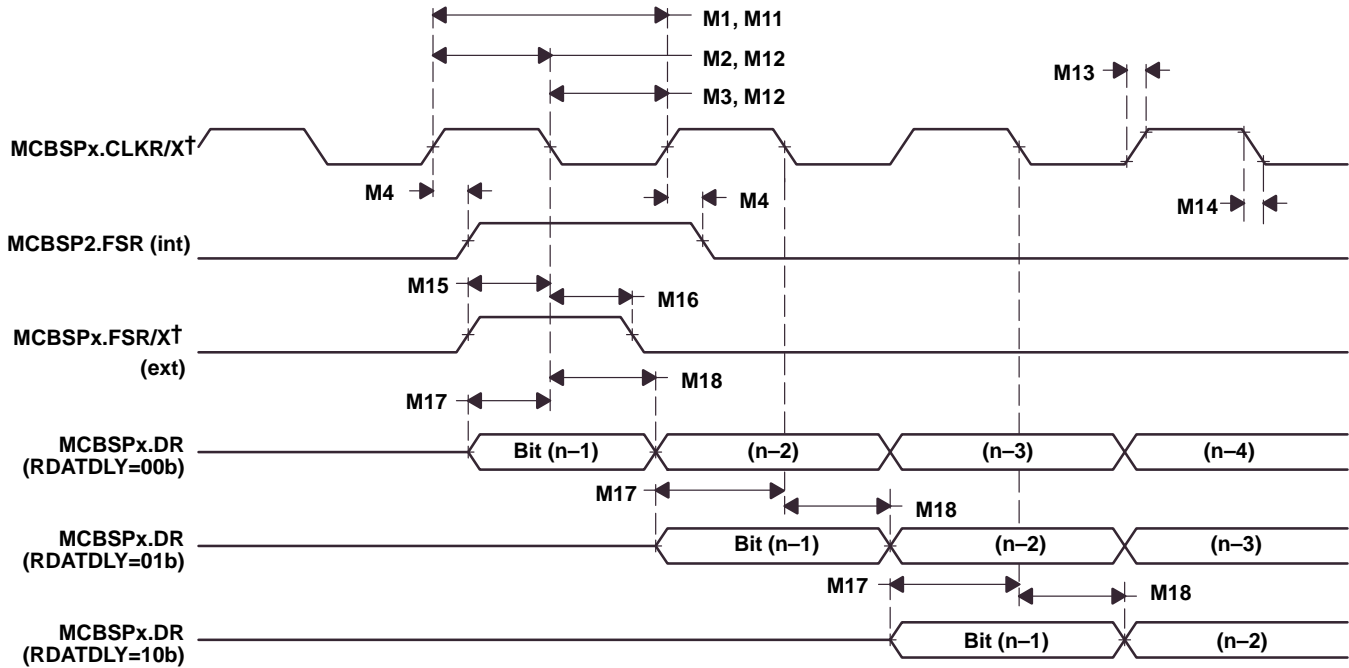

† For McBSP1 and McBSP3, the receiver clock and frame sync inputs are driven by FSX and CLKX via internal loopback connections enabled via software configuration.

Figure 5–18. McBSP Receive Timings

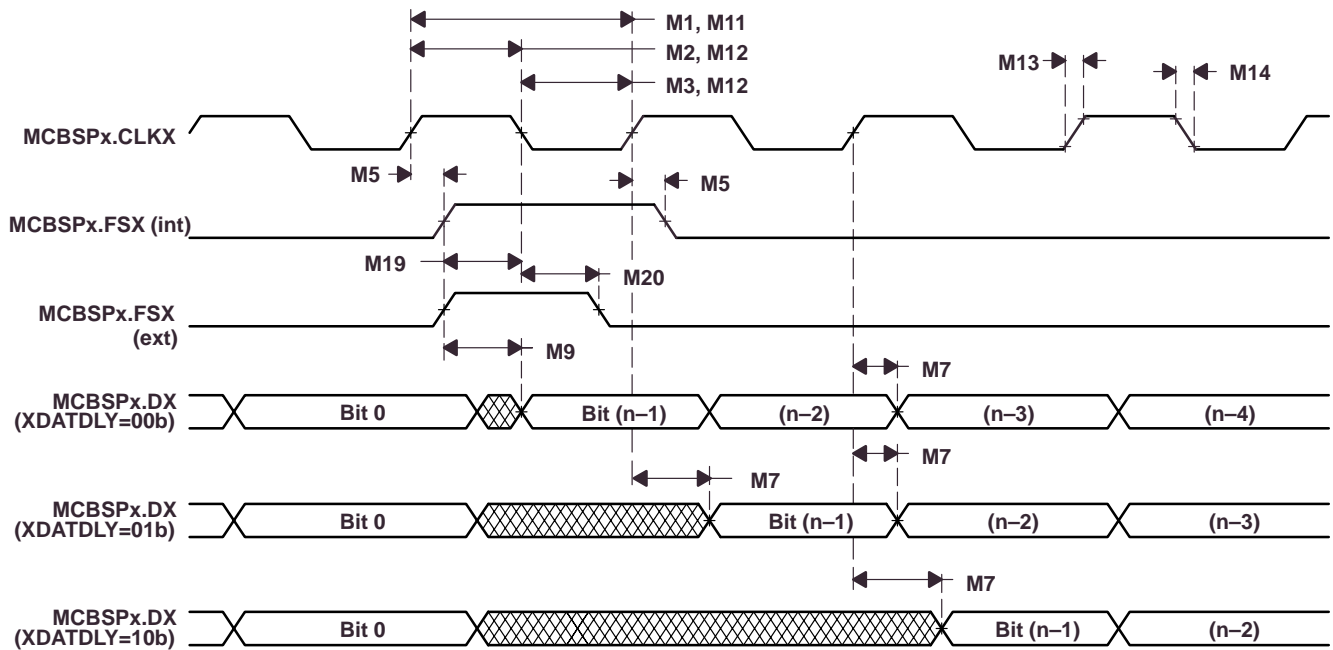

Figure 5–19. McBSP Transmit Timings

5.9.2 McBSP as SPI Master or Slave Timing

Table 5–15 to Table 5–22 assume testing over recommended operating conditions (see Figure 5–20 through Figure 5–23).

Table 5–15. McBSP as SPI Master or Slave Timing Requirements (CLKSTP = 10b, CLKXP = 0)†‡

NO.		MASTER		SLAVE		UNIT
		MIN	MAX	MIN	MAX	
M30	$t_{su}(DRV-CKXL)$ Setup time, MCBSPx.DR valid before MCBSPx.CLKX low	15		2 – 6P		ns
M31	$t_h(CKXL-DRV)$ Hold time, MCBSPx.DR valid after MCBSPx.CLKX low	2		6 + 6P		ns
M32	$t_{su}(BFXL-CKXH)$ Setup time, MCBSPx.FSX low before MCBSPx.CLKX high	McBSP1		21		ns
		McBSP2		5		
		McBSP3		10		
M33	$t_c(CKX)$ Cycle time, MCBSPx.CLKX	2P		16P		ns

† For all SPI slave modes, CLKG is programmed as 1/2 of the internal reference clock by setting CLKSM = CLKGDV = 1.

‡ P = 1/(12 MHz) for McBSP 1 and 3, or 1/(ARMPER_CK clock frequency) in ns for McBSP 2.

Table 5–16. McBSP as SPI Master or Slave Switching Characteristics (CLKSTP = 10b, CLKXP = 0)†‡

NO.	PARAMETER	MASTERS§		SLAVE		UNIT
		MIN	MAX	MIN	MAX	
M24	$t_h(CKXL-FXL)$ Hold time, MCBSPx.FSX low after MCBSPx.CLKX low¶	0.45T	0.55T			ns
M25	$t_d(FXL-CKXH)$ Delay time, MCBSPx.FSX low to MCBSPx.CLKX high#	0.45C	0.55C			ns
M26	$t_d(CKXH-DXV)$ Delay time, MCBSPx.CLKX high to MCBSPx.DX valid	-1	7	3P + 2	5P + 18	ns
M29	$t_d(FXL-DXV)$ Delay time, MCBSPx.FSX low to MCBSPx.DX valid				4P + 18	ns

† For all SPI slave modes, CLKG is programmed as 1/2 of the internal reference clock by setting CLKSM = CLKGDV = 1.

‡ P = 1/(12 MHz) for McBSP 1 and 3, or 1/(ARMPER_CK clock frequency) in ns for McBSP 2.

§ T = CLKX period = (1 + CLKGDV) * P

C = CLKX low pulse width = T/2 when CLKGDV is odd or zero and = (CLKGDV/2) * P when CLKGDV is even

¶ FSRP = FSXP = 1. As a SPI master, MCBSPx.FSX is inverted to provide active-low slave-enable output. As a slave, the active-low signal input on MCBSPx.FSX and MCBSPx.FSR is inverted before being used internally.

CLKXM = FSXM = 1, CLKRM = FSRM = 0 for master McBSP

CLKXM = CLKRM = FSXM = FSRM = 0 for slave McBSP

MCBSPx.FSX should be low before the rising edge of clock to enable slave devices and then begin a SPI transfer at the rising edge of the master clock (MCBSPx.CLKX).

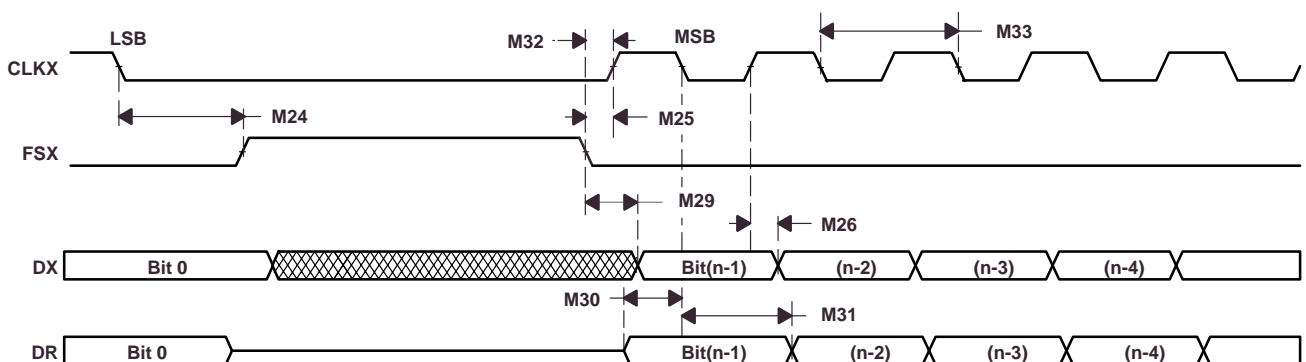

Figure 5–20. McBSP Timing as SPI Master or Slave: CLKSTP = 10b, CLKXP = 0

Table 5–17. McBSP as SPI Master or Slave Timing Requirements (CLKSTP = 11b, CLKXP = 0)†‡

NO.		MASTER		SLAVE		UNIT
		MIN	MAX	MIN	MAX	
M39	$t_{su}(DRV-CKXH)$ Setup time, MCBSPx.DR valid before MCBSPx.CLKX high	15		2 – 6P		ns
M40	$t_h(CKXH-DRV)$ Hold time, MCBSPx.DR valid after MCBSPx.CLKX high	2		6 +6P		ns
M41	$t_{su}(FXL-CKXH)$ Setup time, MCBSPx.FSX low before MCBSPx.CLKX high	McBSP1		21		ns
		McBSP2		5		
		McBSP3		10		
M42	$t_c(CKX)$ Cycle time, MCBSPx.CLKX	2P		16P		ns

† For all SPI slave modes, CLKG is programmed as 1/2 of the internal reference clock by setting CLKSM = CLKGDV = 1.

‡ P = 1/(12 MHz) for McBSP 1 and 3, or 1/(ARMPER_CK clock frequency) in ns for McBSP 2.

Table 5–18. McBSP as SPI Master or Slave Switching Characteristics (CLKSTP = 11b, CLKXP = 0)†‡

NO.	PARAMETER	MASTER§		SLAVE		UNIT
		MIN	MAX	MIN	MAX	
M34	$t_h(CKXL-FXL)$ Hold time, MCBSPx.FSX low after MCBSPx.CLKX low¶	0.45C	0.55C			ns
M35	$t_d(FXL-CKXH)$ Delay time, MCBSPx.FSX low to MCBSPx.CLKX high#	0.45T	0.55T			ns
M36	$t_d(CKXL-DXV)$ Delay time, MCBSPx.CLKX low to MCBSPx.DX valid	-1	7	3P + 2	5P + 18	ns
M38	$t_d(FXL-DXV)$ Delay time, MCBSPx.FSX low to MCBSPx.DX valid		D + 20		4P + 18	ns

† For all SPI slave modes, CLKG is programmed as 1/2 of the internal reference clock by setting CLKSM = CLKGDV = 1.

‡ P = 1/(12 MHz) for McBSP 1 and 3, or 1/(ARMPER_CK clock frequency) in ns for McBSP 2.

§ T = CLKX period = (1 + CLKGDV) * P

C = CLKX low pulse width = T/2 when CLKGDV is odd or zero and = (CLKGDV/2) * P when CLKGDV is even

D = CLKX high pulse width = T/2 when CLKGDV is odd or zero and = (CLKGDV/2 + 1) * P when CLKGDV is even

¶ FSRP = FSXP = 1. As a SPI master, MCBSPx.FSX is inverted to provide active-low slave-enable output. As a slave, the active-low signal input on MCBSPx.FSX and MCBSPx.FSR is inverted before being used internally.

CLKXM = FSXM = 1, CLKRM = FSRM = 0 for master McBSP

CLKXM = CLKRM = FSXM = FSRM = 0 for slave McBSP

MCBSPx.FSX should be low before the rising edge of clock to enable slave devices and then begin a SPI transfer at the rising edge of the master clock (MCBSPx.CLKX).

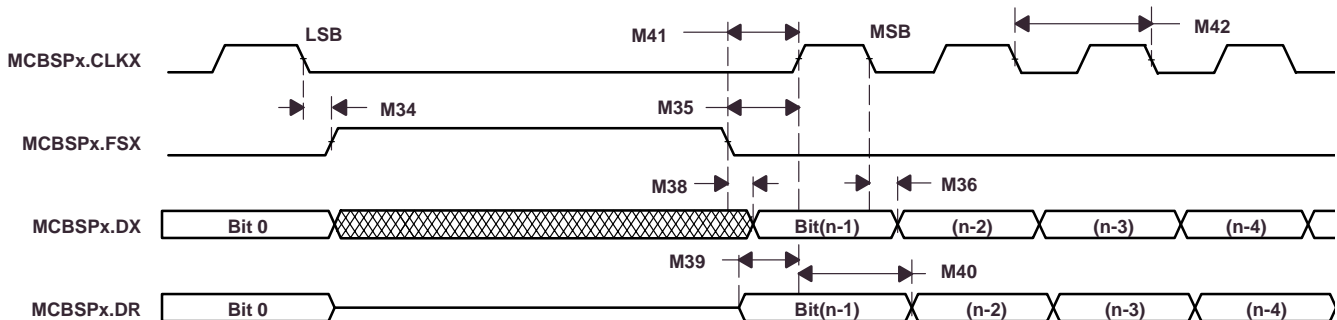

Figure 5–21. McBSP Timing as SPI Master or Slave: CLKSTP = 11b, CLKXP = 0

PRODUCT PREVIEW

Table 5–19. McBSP as SPI Master or Slave Timing Requirements (CLKSTP = 10b, CLKXP = 1)†‡

NO.	MIN	MASTER		SLAVE		UNIT
		MIN	MAX	MIN	MAX	
M49	$t_{su}(DRV-CKXH)$	Setup time, MCBSPx.DR valid before MCBSPx.CLKX high		15	2 – 2P	ns
M50	$t_h(CKXH-DRV)$	Hold time, MCBSPx.DR valid after MCBSPx.CLKX high		2	6 + 6P	ns
M51	$t_{su}(FXL-CKXL)$	Setup time, MCBSPx.FSX low before MCBSPx.CLKX low		McBSP1	21	ns
				McBSP2	5	
				McBSP3	10	
M52	$t_c(CKX)$	Cycle time, MCBSPx.CLKX		2P	16P	ns

† For all SPI slave modes, CLKG is programmed as 1/2 of the CPU clock by setting CLKSM = CLKGDV = 1.

‡ P = 1/(12 MHz) for McBSP 1 and 3, or 1/(ARMPER_CK clock frequency) in ns for McBSP 2.

Table 5–20. McBSP as SPI Master or Slave Switching Characteristics (CLKSTP = 10b, CLKXP = 1)†‡

NO.	PARAMETER	MASTER§		SLAVE		UNIT
		MIN	MAX	MIN	MAX	
M43	$t_h(CKXH-FXL)$	Hold time, MCBSPx.FSX low after MCBSPx.CLKX high¶		0.45T	0.55T	ns
M44	$t_d(FXL-CKXL)$	Delay time, MCBSPx.FSX low to MCBSPx.CLKX low#		0.45D	0.55D	ns
M45	$t_d(CKXL-DXV)$	Delay time, MCBSPx.CLKX low to MCBSPx.DX valid		-1	7	3P + 2 5P + 18
M48	$t_d(FXL-DXV)$	Delay time, MCBSPx.FSX low to MCBSPx.DX valid				4P + 18

† For all SPI slave modes, CLKG is programmed as 1/2 of the internal reference clock by setting CLKSM = CLKGDV = 1.

‡ P = 1/(12 MHz) for McBSP 1 and 3, or 1/(ARMPER_CK clock frequency) in ns for McBSP 2.

§ T = CLKX period = (1 + CLKGDV) * P

D = CLKX high pulse width = T/2 when CLKGDV is odd or zero and = (CLKGDV/2 + 1) * P when CLKGDV is even

¶ FSRP = FSXP = 1. As a SPI master, MCBSPx.FSX is inverted to provide active-low slave-enable output. As a slave, the active-low signal input on MCBSPx.FSX and MCBSPx.FSR is inverted before being used internally.

CLKXM = FSXM = 1, CLKRM = FSRM = 0 for master McBSP

CLKXM = CLKRM = FSXM = FSRM = 0 for slave McBSP

MCBSPx.FSX should be low before the rising edge of clock to enable slave devices and then begin a SPI transfer at the rising edge of the master clock (MCBSPx.CLKX).

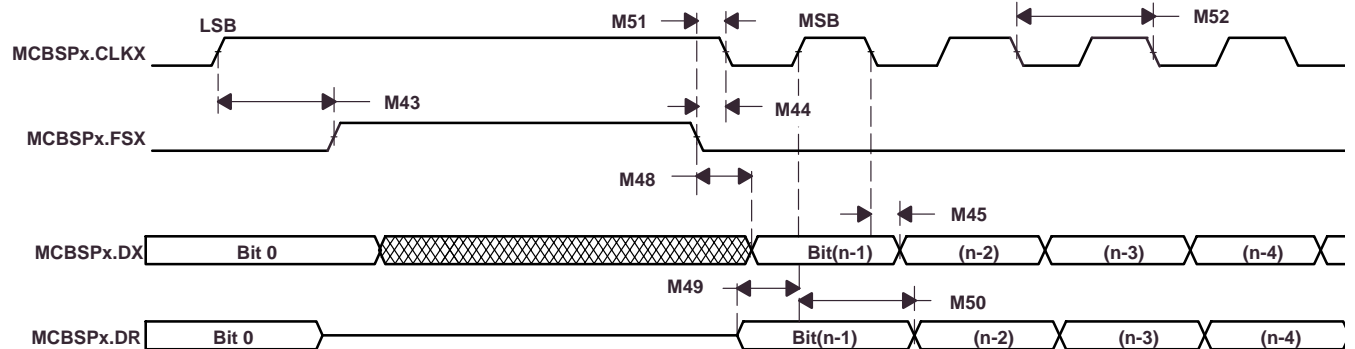

Figure 5–22. McBSP Timing as SPI Master or Slave: CLKSTP = 10b, CLKXP = 1

Table 5–21. McBSP as SPI Master or Slave Timing Requirements (CLKSTP = 11b, CLKXP = 1)†‡

NO.	MIN	MASTER		SLAVE		UNIT
		MIN	MAX	MIN	MAX	
M58	$t_{su}(DRV-CKXL)$	Setup time, MCBSPx.DR valid before MCBSPx.CLKX low		15	2 – 6P	ns
M59	$t_h(CKXL-DRV)$	Hold time, MCBSPx.DR valid after MCBSPx.CLKX low		2	6 + 6P	ns
M60	$t_{su}(FXL-CKXL)$	Setup time, MCBSPx.FSX low before MCBSPx.CLKX low		McBSP1	21	ns
				McBSP2	5	
				McBSP3	10	
M61	$t_c(CKX)$	Cycle time, MCBSPx.CLKX		2P	16P	ns

† For all SPI slave modes, CLKG is programmed as 1/2 of the internal reference clock by setting CLKSM = CLKGDV = 1.

‡ P = 1/(12 MHz) for McBSP 1 and 3, or 1/(ARMPER_CK clock frequency) in ns for McBSP 2.

Table 5–22. McBSP as SPI Master or Slave Switching Characteristics (CLKSTP = 11b, CLKXP = 1)†‡

NO.	PARAMETER	MASTER§		SLAVE		UNIT
		MIN	MAX	MIN	MAX	
M53	$t_h(CKXH-FXL)$	Hold time, MCBSPx.FSX low after MCBSPx.CLKX high¶		0.45D	0.55D	ns
M54	$t_d(FXL-CKXL)$	Delay time, MCBSPx.FSX low to MCBSPx.CLKX low#		0.45T	0.55T	ns
M55	$t_d(CKXH-DXV)$	Delay time, MCBSPx.CLKX high to MCBSPx.DX valid		-1	7	3P + 2 5P + 18
M57	$t_d(FXL-DXV)$	Delay time, MCBSPx.FSX low to MCBSPx.DX valid		C + 20		4P + 18

† For all SPI slave modes, CLKG is programmed as 1/2 of the internal reference clock by setting CLKSM = CLKGDV = 1.

‡ P = 1/(12 MHz) for McBSP 1 and 3, or 1/(ARMPER_CK clock frequency) in ns for McBSP 2.

§ T = CLKX period = (1 + CLKGDV) * P

C = CLKX low pulse width = T/2 when CLKGDV is odd or zero and = (CLKGDV/2) * P when CLKGDV is even

D = CLKX high pulse width = T/2 when CLKGDV is odd or zero and = (CLKGDV/2 + 1) * P when CLKGDV is even

¶ FSRP = FSXP = 1. As a SPI master, MCBSPx.FSX is inverted to provide active-low slave-enable output. As a slave, the active-low signal input on MCBSPx.FSX and MCBSPx.FSR is inverted before being used internally.

CLKXM = FSXM = 1, CLKRM = FSRM = 0 for master McBSP

CLKXM = CLKRM = FSXM = FSRM = 0 for slave McBSP

MCBSPx.FSX should be low before the rising edge of clock to enable slave devices and then begin a SPI transfer at the rising edge of the master clock (MCBSPx.CLKX).

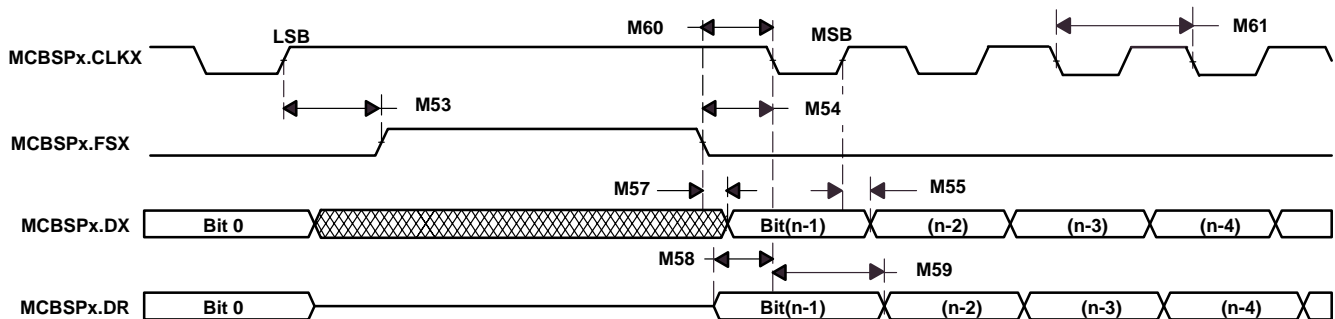

Figure 5–23. McBSP Timing as SPI Master or Slave: CLKSTP = 11b, CLKXP = 1

PRODUCT PREVIEW

5.10 Multichannel Serial Interface (MCSI)

Table 5–23 and Table 5–24 assume testing over recommended operating conditions (see Figure 5–24 and Figure 5–25).

Table 5–23. MCSI Timing Requirements

NO.	PARAMETER			MIN	MAX	UNIT
MC11	$f_{op}(CLK)$	Operating frequency, MCSIx.CLK	Slave		12	MHz
MC12	$t_w(CLKH)$	Pulse duration, MCSIx.CLK high	Slave	$0.45P^\dagger$	$0.55P^\dagger$	ns
MC13	$t_w(CLKL)$	Pulse duration, MCSIx.CLK low	Slave	$0.45P^\dagger$	$0.55P^\dagger$	ns
MC14	$t_r(CLK)$	Rise time, MCSIx.CLK	Slave		6	ns
MC15	$t_f(CLK)$	Fall time, MCSIx.CLK	Slave		6	ns
MC16	$t_{su}(FSH-CLKL)$	Setup time, external MCSIx.SYNC high before MCSIx.CLK low	Slave	12		ns
MC17	$t_h(CLKL-FSH)$	Hold time, external MCSIx.SYNC high after MCSIx.CLK low	Slave	0		ns
MC18	$t_{su}(DIV-CLKL)$	Setup time, MCSIx.DIN valid before MCSIx.CLK low	Master	18		ns
			Slave	12		
MC19	$t_h(CLKL-DIV)$	Hold time, MCSIx.DIN valid after MCSIx.CLK low	Master	0		ns
			Slave	0		

$^\dagger P$ = MCSIx.CLK period [$t_c(CLK)$] in nanoseconds.

Table 5–24. MCSI Switching Characteristics

NO.	PARAMETER			MIN	MAX	UNIT
MC1	$f_{op}(CLK)$	Operating frequency, MCSIx.CLK	Master		6	MHz
MC2	$t_w(CLKH)$	Pulse duration, MCSIx.CLK high	Master	$0.45P^\dagger$	$0.55P^\dagger$	ns
MC3	$t_w(CLKL)$	Pulse duration, MCSIx.CLK low	Master	$0.45P^\dagger$	$0.55P^\dagger$	ns
MC4	$t_d(CLKH-FS)$	Delay time, MCSIx.CLK high to MCSIx.SYNC transition	Master	0	3	ns
MC7	$t_d(CLKH-DOV)$	Delay time, MCSIx.CLK high to MCSIx.DOUT valid	Master	0	3	ns
			Slave	5	20	
MC8	$t_{en}(CLKH-DO)$	Enable time, MCSIx.DOUT driven from MCSIx.CLK high	Master	0		ns
			Slave	5		

$^\dagger P$ = MCSIx.CLK period [$t_c(CLK)$] in nanoseconds.

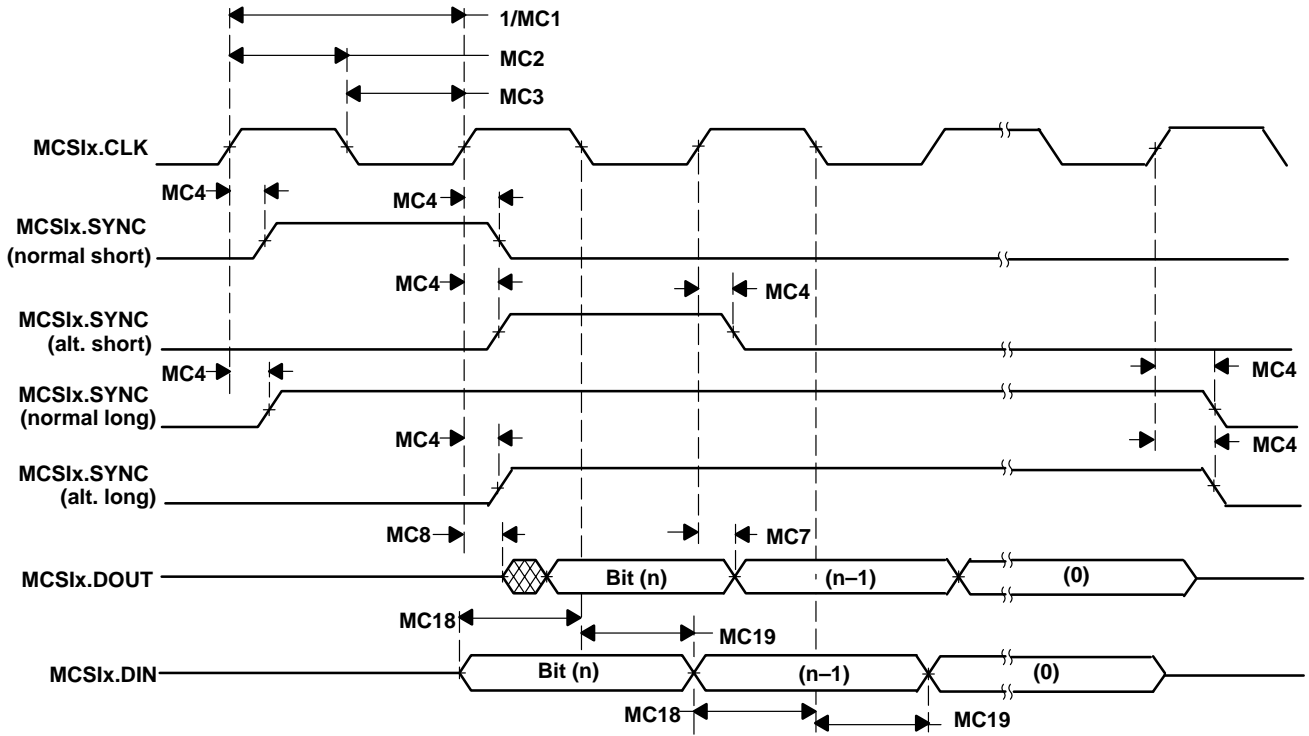

Figure 5–24. MCSI Master Mode Timings

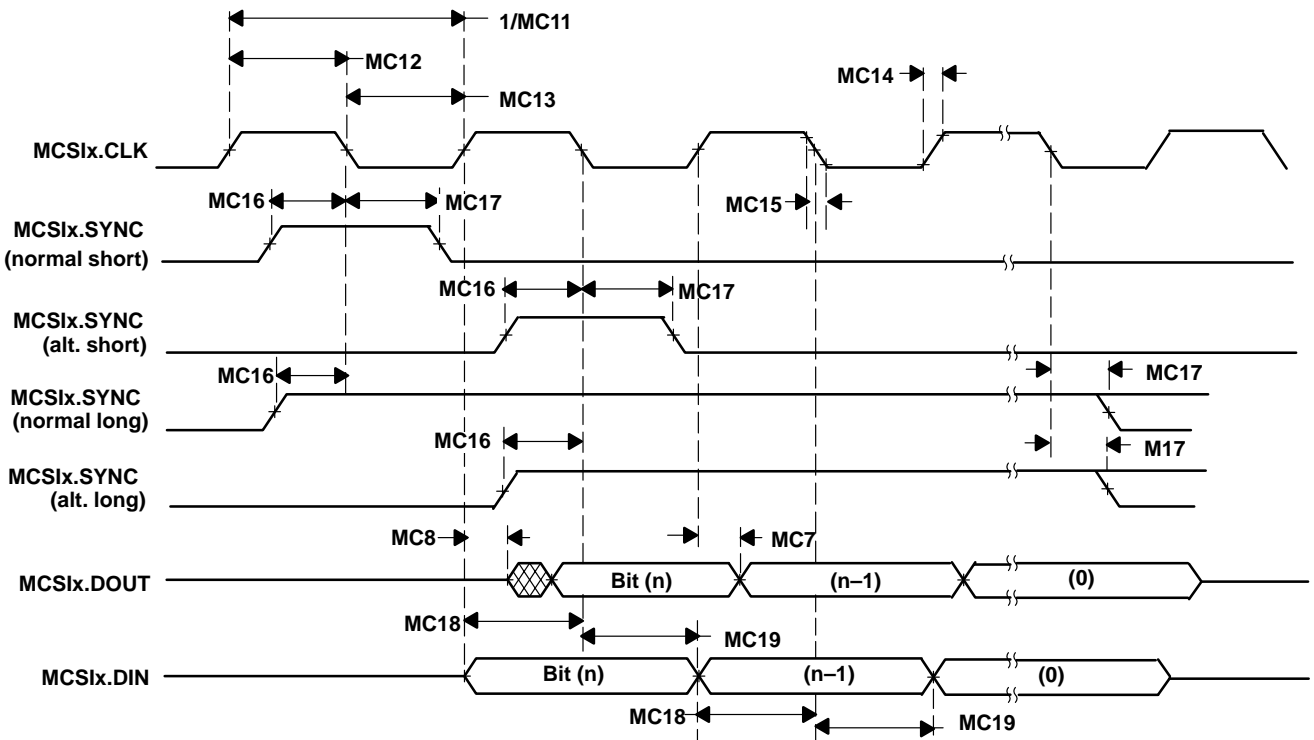

Figure 5–25. MCSI Slave Mode Timings

5.11 Camera Interface Timings

Table 5–25 assumes testing over recommended operating conditions (see Figure 5–26).

Table 5–25. Camera Interface Timing Requirements

NO.		MIN	MAX	UNIT
C1	$1 / [t_c(LCKH-HSV)]$ Operating frequency, CAM.LCLK		13	MHz
C2	$1 / [t_c(XCKH-HSV)]$ Operating frequency, CAM.EXCLK		24	MHz
C3	$t_w(LCK)$ Pulse duration, CAM.LCLK high or low	0.45P [†]	0.55P [†]	ns
C5	$t_{su}(LCKH-DV)$ Setup time, CAM.D[7:0] data valid before CAM.LCLK high	1‡		ns
C6	$t_h(DV-LCKH)$ Hold time, CAM.D[7:0] data valid after CAM.LCLK high	6‡		ns
C7	$t_{su}(LCKH-DV)$ Setup time, CAM.VS/CAM.HS active before CAM.LCLK high	1‡		ns
C8	$t_h(DV-CLKH)$ Hold time, CAM.VS/CAM.HS active after CAM.LCLK high	6‡		ns

[†] P = period of CAM.LCLK in nanoseconds (ns).

[‡] Polarity of CAM.LCLK is selectable via the POLCLK bit in the CTRLCLOCK register. Although data is latched on rising CAM.LCLK in the timing diagrams, these timing parameters also apply to falling CAM.LCLK when POLCLK = 1.

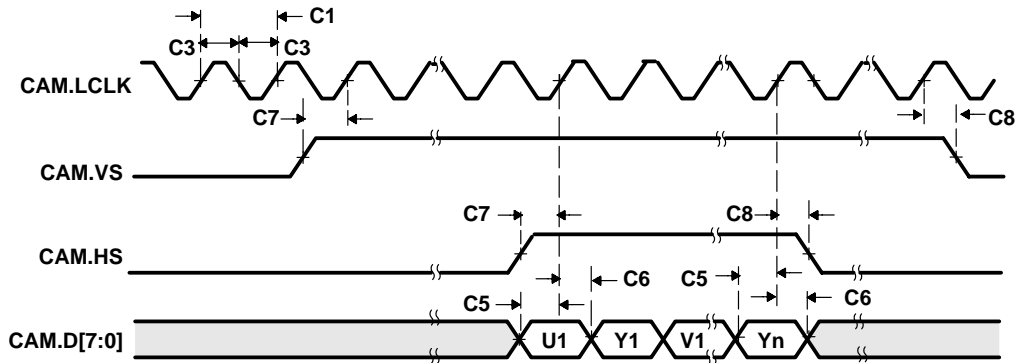

Figure 5–26. Camera Interface Timings

PRODUCT PREVIEW

5.12 LCD Controller Timings

Table 5–26 assumes testing over recommended operating conditions (see Figure 5–27 and Figure 5–28).

Table 5–26. LCD Controller Switching Characteristics †

NO.	PARAMETER	MIN	MAX	UNIT
L1	$t_d(\text{CLKH-HSV})$ Delay time, LCD.PCLK high to LCD.HS transition	1	7	ns
L2	$t_d(\text{CLKL-HSV})$ Delay time, LCD.PCLK low to LCD.HS transition	1	7	ns
L3	$t_d(\text{CLKH-VSV})$ Delay time, LCD.PCLK high to LCD.VS transition	1	7	ns
L4	$t_d(\text{CLKL-VSV})$ Delay time, LCD.PCLK low to LCD.VS transition	1	7	ns
L5	$t_d(\text{CLKH-PV})$ Delay time, LCD.PCLK high to pixel data valid (LCD.P[15:0])		7	ns
L6	$t_d(\text{CLKH-PIV})$ Delay time, LCD.PCLK high to pixel data invalid (LCD.P[15:0])	1		ns
L7	$t_d(\text{CLKL-PV})$ Delay time, LCD.PCLK low to pixel data valid (LCD.P[15:0])		7	ns
L8	$t_d(\text{CLKL-PIV})$ Delay time, LCD.PCLK low to pixel data invalid (LCD.P[15:0])	1		ns
L9	$t_d(\text{CLKL-ACV})$ Delay time, LCD.PCLK high to LCD.AC transition	1	$5+P‡$	ns
L10	$t_d(\text{CLKL-ACV})$ Delay time, LCD.PCLK low to LCD.AC transition	1	$5+P‡$	ns

† Although timing diagrams illustrate the logical function of the TFT mode, static timings apply to all supported modes of operation. Likewise, LCD.HS, LCD.VS, and LCD.AC are shown as active-low, but each may optionally be configured as active-high.

‡ P = period of internal undivided pixel clock

PRODUCT PREVIEW

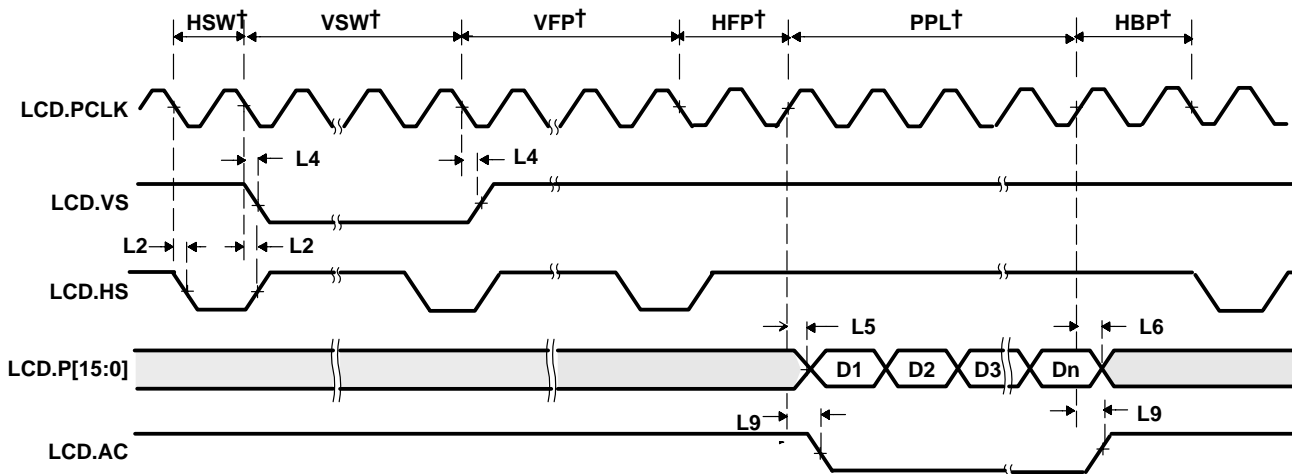

† Delays for HSW (LCD.HS Width), VSW (LCD.VS Width), VFP (Vertical Front Porch), HFP (Horizontal Front Porch), HBP (Horizontal Back Porch) and PPL (Pixels per Line) are programmable in number of LCD.PCLK cycles via the LCD configuration registers.

Figure 5–27. TFT Mode (LCD.HS/LCD.VS on Falling and LCD.Px on Rising LCD.PCLK)

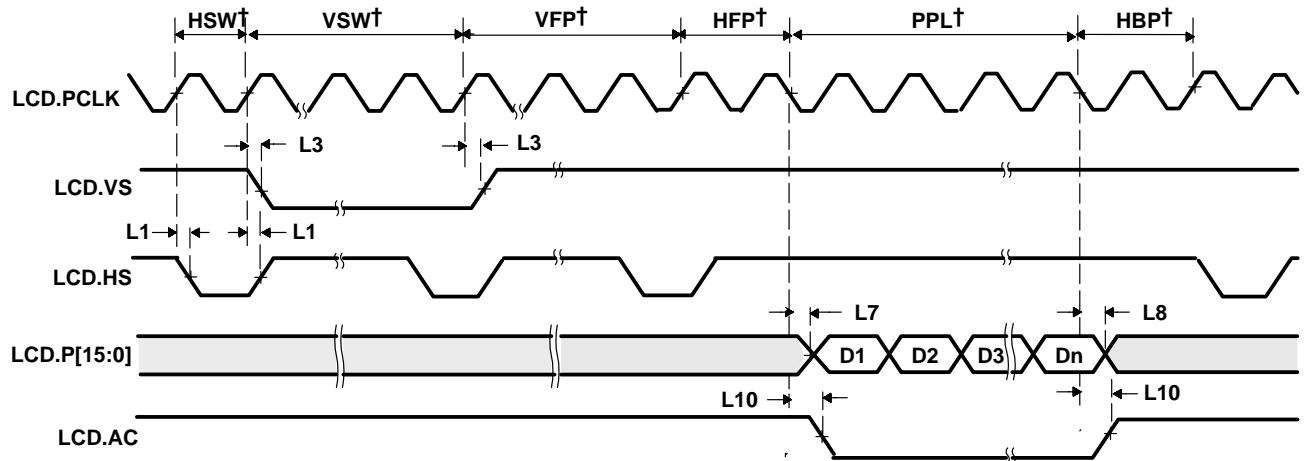

† Delays for HSW (LCD.HS Width), VSW (LCD.VS Width), VFP (Vertical Front Porch), HFP (Horizontal Front Porch), HBP (Horizontal Back Porch) and PPL (Pixels per Line) are programmable in number of LCD.PCLK cycles via the LCD configuration registers.

Figure 5–28. TFT Mode (LCD.HS/LCD.VS on Rising and LCD.Px on Falling LCD.PCLK)

5.13 Multimedia Card/Secure Digital (MMC/SD) Timings

Table 5–27 and Table 5–28 assume testing over recommended operating conditions (see Figure 5–29 through Figure 5–32).

Table 5–27. MMC/SD Timing Requirements

NO.		MIN	MAX	UNIT
M1	$t_{su}(CMDV-CLKH)$ Setup time, MMC.CMD valid before MMC.CLK high	3		ns
M2	$t_h(CLKH-CMDV)$ Hold time, MMC.CMD invalid after MMC.CLK high	1		ns
M3	$t_{su}(DATV-CLKH)$ Setup time, MMC.DATx valid before MMC.CLK high	3		ns
M4	$t_h(CLKH-DATV)$ Hold time, MMC.DATx invalid after MMC.CLK high	1		ns

Table 5–28. MMC/SD Switching Characteristics

NO.	PARAMETER	MIN	MAX	UNIT
M7	$t_c(CLK)$ Cycle time, MMC.CLK	41.7		ns
			5.31	us
M8	$t_w(CLKH)$ Pulse Duration, MMC.CLK high	20 [†]		ns
M9	$t_w(CLKL)$ Pulse Duration, MMC.CLK low	20 [†]		ns
M10	$t_d(CLKL-CMD)$ Delay time, MMC.CLK low to MMC.CMD transition	8	32	ns
M11	$t_d(CLKL-DAT)$ Delay time, MMC.CLK low to MMC.DATx transition	8	32	ns

[†] MMC.CLK period and pulse duration depends upon software configuration.

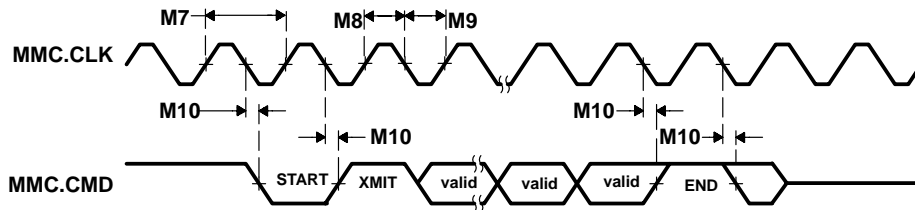

Figure 5–29. MMC/SD Host Command Timings

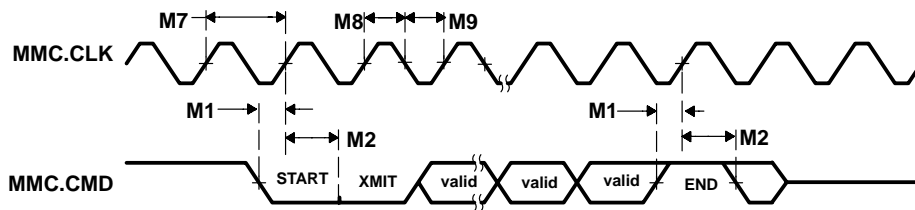

Figure 5–30. MMC/SD Card Response Timings

PRODUCT PREVIEW

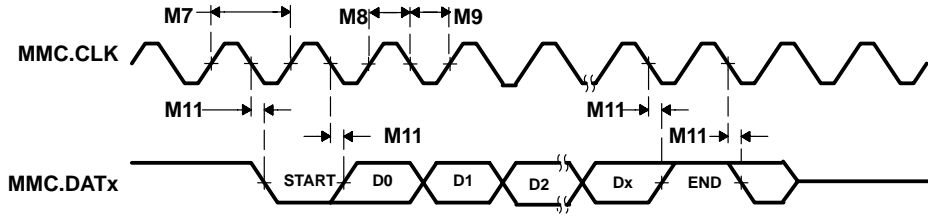

Figure 5–31. MMC/SD Host Write Timings

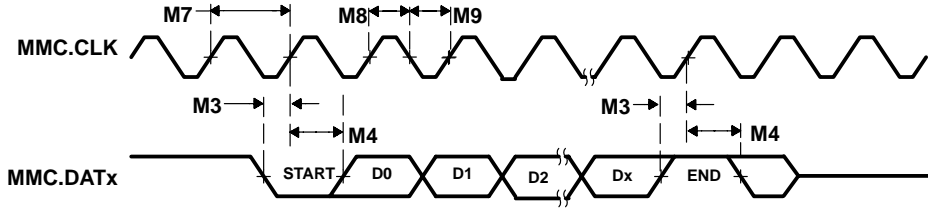

Figure 5–32. MMC/SD Host Read and Card CRC Status Timings

5.14 I²C Timings

Table 5–29 assumes testing over recommended operating conditions (see Figure 5–33).

Table 5–29. I²C Signals (I2C.SDA and I2C.SCL) Switching Characteristics

NO.	PARAMETER		STANDARD MODE		FAST MODE		UNIT
			MIN	MAX	MIN	MAX	
IC1	$t_c(\text{SCL})$	Cycle time, I2C.SCL	10		2.5		μs
IC2	$t_{su}(\text{SCLH-SDAL})$	Setup time, I2C.SCL high before I2C.SDA low (for a repeated START condition)	4.7		0.6		μs
IC3	$t_h(\text{SCLL-SDAL})$	Hold time, I2C.SCL low after I2C.SDA low (for a repeated START condition)	4		0.6		μs
IC4	$t_w(\text{SCLL})$	Pulse duration, I2C.SCL low	4.7		1.3		μs
IC5	$t_w(\text{SCLH})$	Pulse duration, I2C.SCL high	4		0.6		μs
IC6	$t_{su}(\text{SDA-SDLH})$	Setup time, I2C.SDA valid before I2C.SCL high	250	†	100		ns
IC7	$t_h(\text{SDA-SDLL})$	Hold time, I2C.SDA valid after I2C.SCL low	For CBUS compatible masters		5		μs
			For I ² C bus devices		0	0 0.9	
IC8	$t_w(\text{SDAH})$	Pulse duration, I2C.SDA high between STOP and START conditions	4.7		1.3		μs
IC9	$t_r(\text{SDA})$	Rise time, I2C.SDA		1000		300	ns
IC10	$t_r(\text{SCL})$	Rise time, I2C.SCL		1000		300	
IC11	$t_f(\text{SDA})$	Fall time, I2C.SDA		300		300	ns
IC12	$t_f(\text{SCL})$	Fall time, I2C.SCL		300		300	
IC13	$t_{su}(\text{SCLH-SDAH})$	Setup time, I2C.SCL high before I2C.SDA high (for STOP condition)	4.0		0.6		μs
IC14	$t_w(\text{SP})$	Pulse duration, spike (must be suppressed)			0	50	ns
IC15	C_b^\ddagger	Capacitive load for each bus line		400		400	pF

† The maximum $t_h(\text{SCLL-SDAL})$ has only to be met if the device does not stretch the low period ($t_w(\text{SCLL})$) of the I2C.SCL signal.

‡ C_b = The total capacitance of one bus line in pF.

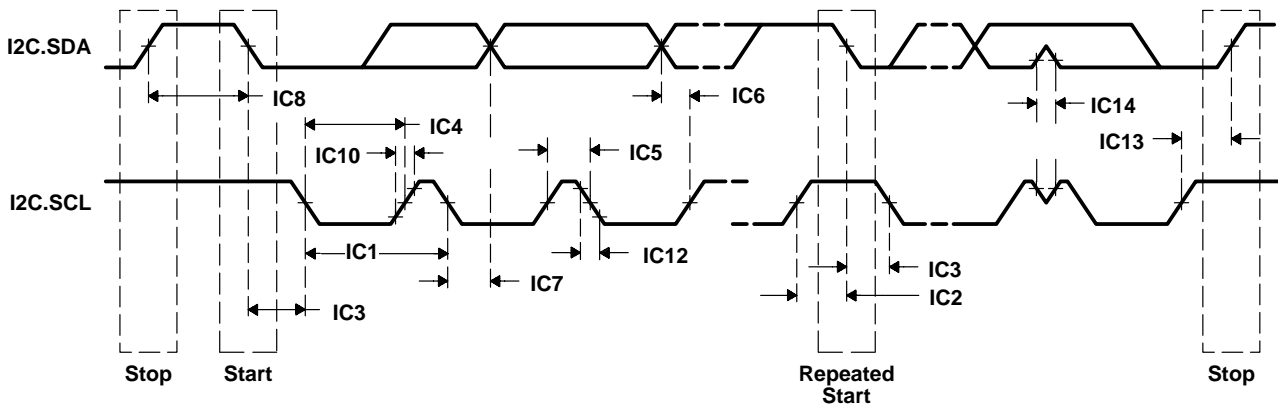

- NOTES:
- A. A device must internally provide a hold time of at least 300 ns for the I2C.SDA signal (referred to the V_{IHmin} of the I2C.SCL signal) to bridge the undefined region of the falling edge of I2C.SCL.
 - B. The maximum $t_h(\text{SCLL-SDAL})$ has only to be met if the device does not stretch the LOW period ($t_w(\text{SCLL})$) of the I2C.SCL signal.
 - C. A Fast-mode I²C-bus device can be used in a Standard-mode I²C-bus system, but the requirement $t_{su}(\text{SDA-SDLH}) \cdot 250$ ns must then be met. This will automatically be the case if the device does not stretch the LOW period of the I2C.SCL signal. If such a device does stretch the LOW period of the I2C.SCL signal, it must output the next data bit to the I2C.SDA line $t_r \text{ max} + t_{su}(\text{SDA-SDLH}) = 1000 + 250 = 1250$ ns (according to the standard-mode I²C-bus specification) before the I2C.SCL line is released.
 - D. C_b = total capacitance of one bus line in pF. If mixed with fast-mode devices, faster fall times are allowed.

Figure 5–33. I²C Timings

5.15 Universal Serial Bus (USB) Timings

All OMAP5910 USB interfaces are compliant with Universal Serial Bus Specification, Revision 1.1. Table 5–30 assumes testing over recommended operating conditions (see Figure 5–34).

Table 5–30. USB Integrated Transceiver Interface Switching Characteristics

NO.	PARAMETER	LOW SPEED 1.5 Mbps		FULL SPEED 12 Mbps		UNIT
		MIN	MAX	MIN	MAX	
U1	t_r Rise time, USB.DP and USB.DM signals†	75†	300†	4†	20†	ns
U2	t_f Fall time, USB.DP and USB.DM signals†	75†	300†	4†	20†	ns
U3	t_{RFM} Rise/Fall time matching‡	80‡	125‡	90‡	111.11‡	%
U4	V_{CRS} Output signal cross-over voltage†	1.3†	2.0†	1.3†	2.0†	V
U5	t_{jr} Differential propagation jitter§	-25§	25§	-2§	2§	ns
U6	f_{op} Operating frequency¶		1.5		12	MHz

† Low Speed: $C_L = 200$ pF, High Speed: $C_L = 50$ pF

‡ $t_{RFM} = (t_r/t_f) \times 100$

§ $t_{jr} = t_{px(1)} - t_{px(0)}$

¶ $f_{op} = 1/t_{per}$

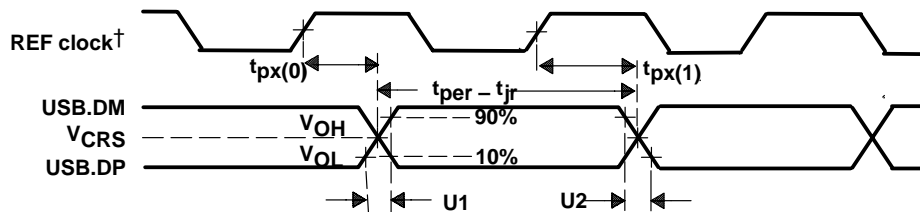

† “REF clock” is not an actual device signal, but an ideal reference clock against which relative timings are specified. REF clock is assumed to be 12 MHz for full-speed mode or 1.5 MHz for low-speed mode).

Figure 5–34. USB Integrated Transceiver Interface Timings

PRODUCT PREVIEW

5.16 Microwire Interface Timings

Table 5–31 and Table 5–32 assume testing over recommended operating conditions (see Figure 5–29 through Figure 5–35).

Table 5–31. Microwire Timing Requirements

NO.	PARAMETER	MIN	MAX	UNIT
W5	$t_{su}(SDI-SCLK)$ Setup time, UWIRE.SDI valid before UWIRE.SCLK active edge†	14		ns
W6	$t_h(SCLK-SDI)$ Hold time, UWIRE.SDI invalid after UWIRE.SCLK active edge†	1		ns

† Polarity of UWIRE.SCLK and the active clock edge (rising or falling) on which SDO data is driven and SDI data is latched is all software configurable. These timings apply to all configurations regardless of UWIRE.SCLK polarity and which clock edges are used to drive output data and capture input data.

Table 5–32. Microwire Switching Characteristics

NO.	PARAMETER	MIN	MAX	UNIT
W1	$f_{op}(SCLK)$ Operating Frequency, UWIRE.SCLK		3	MHz
W2	$t_w(SCLK)$ Pulse Duration, UWIRE.SCLK high/low	0.45P‡	0.55P‡	ns
W3	$t_d(SCLK-SDO)$ Delay time, UWIRE.SCLK active edge to UWIRE.SDO transition†	-2	4	ns
W4	$t_d(CS-SCLK)$ Delay time, UWIRE.CSx active to UWIRE.SCLK active†	2P‡		ns

† Polarity of UWIRE.SCLK and the active clock edge (rising or falling) on which SDO data is driven and SDI data is latched is all software configurable. These timings apply to all configurations regardless of UWIRE.SCLK polarity and which clock edges are used to drive output data and capture input data.

‡ P = UWIRE.SCLK cycle time in ns.

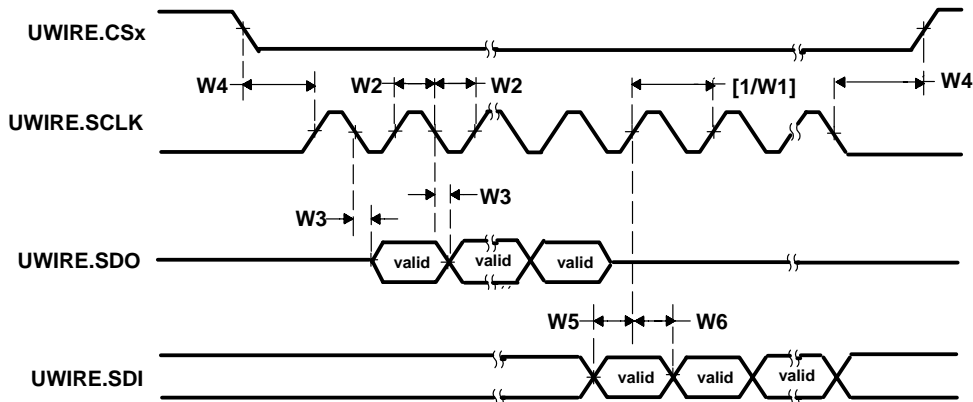

NOTE: The polarities of UWIRE.CSx and UWIRE.SCLK and the active UWIRE.SCLK edges on which SDO is driven and SDI is sampled are all software configurable.

Figure 5–35. Microwire Timings

PRODUCT PREVIEW

6 Glossary

ACRONYM	DEFINITION
1-wire	a serial protocol defined by Dallas Semiconductor Corporation
AAC	Advanced Audio Coding (standard) (ISO/IEC 13818-7)
AC97	Interface Standard for Codecs
ALU	arithmetic/logic unit
AMR	Adaptive Multi-Rate
ASRAM	asynchronous static RAM
AU	address unit
BCD	binary coded decimal
BGA	ball grid array
CMOS	complementary metal oxide semiconductor
CP15	coprocessor 15
CRC	cyclic redundancy check
CSL	Chip Support Library
CTS	clear-to-send
DARAM	dual-access RAM
DCT	discrete cosine transform
DMA	direct memory access
DPLL	digital phase-locked loop
DSP	digital signal processor
DSPLIB	DSP Library
DSR	data-set-ready
DTR	data-terminal-ready
DU	data unit
EMIFF	external memory interface fast
EMIFS	external memory interface slow
EP	endpoint
ESD	electrostatic discharge
ETM	
FAC	frame adjustment counter
FFT	Fast Fourier Transform
FIFO	first-in first out
FIQ	fast interrupt request
GPRS	General Packet Radio Service
GSM	Global System for Mobile Communications
H.26x	an ITU-TSS standard
HBM	Human Body Model
HBP	Horizontal Back Porch

ACRONYM	DEFINITION
HDQ	a single-wire serial interface protocol defined by Benchmarq™ Controls Inc.
HFP	Horizontal Front Porch
HOM	host-only mode
HS	high-speed
I-cache	instruction cache
I ² C	Inter-integrated circuit
I ² S	Inter-IC Sound (specification)
iDCT	Inverse Discrete Cosine Transform
I/F	interface
IFR	Interrupt Flag Register
IMGLIB	Image/Video Processing Library
IMIF	internal memory interface
IMR	Interrupt Mask Register
IOM-2	ISDN Oriented Modular Interface Revision 2
IrDA	infrared data adapter
IRQ	low-priority interrupt request
IU	instruction unit
JPEG	Joint Photographic Experts Group – standard for compressed still-picture data
LB	local bus
LCD	liquid crystal display
LPG	LED pulse generator
LSB	least significant bit
LVC MOS	low-voltage CMOS
MAC	multiply-accumulate
MCSI	multichannel serial interface
McBSP	multichannel buffered serial port
MMC	multimedia card
MMC/SD	multimedia card/secure digital
MMU	memory management unit
MPEG	Moving Picture Experts Group – proposed standard for compressed video data
MPU	microprocessor unit
MPUI	microprocessor unit interface
MPUIO	microprocessor unit I/O
MSB	most significant bit
MVIP	multi-vendor integration protocol
ODM	original design manufacturer
OEM	original equipment manufacturer
OHCI	Open Host Controller Interface

Benchmarq is a trademark of Texas Instruments.

ACRONYM	DEFINITION
OS	operating system
PPL	pixels per line
PU	program unit
PWL	pulse-width light
PWT	pulse-width tone
RISC	reduced instruction set computer
RTC	real-time clock
RTS	request-to-send
SAM	shared-access mode
SARAM	single-access RAM
SD	secure digital
SDRAM	synchronous dynamic RAM
SDW	short distance wireless
SIR	slow infrared
SPI	serial peripheral interface
SRAM	static RAM
SRG	Sample Rate Generator
STN	super twisted nematic
T1/E1	T1 is a digital transmission link with a capacity of 1.544 Mbps. It uses two pairs of normal twisted-wires and can handle 24-voice conversations, each digitized using mu-law coding at 64 kbps. T1 is used in USA, Canada, Hong Kong, and Japan. E1 is a digital transmission link with a capacity of 2.048 Mbps. It is the European equivalent of T1. It can handle 30-voice conversations, each digitized using A-law coding at 64 kbps.
TAP	test access port
TC	traffic controller
TFT	thin-film transistor
TI	Texas Instruments
TIPB	TI peripheral bus
TLB	Translation Look-Aside Buffer
TTB	Translation Table Base
UART	universal asynchronous receiver/transmitter
ULPD	ultra low-power device
URL	uniform resource locator
USB	universal serial bus
USB1.1	Universal Serial Bus Specification Revision 1.1
VFP	Vertical Front Porch
VIVT	virtual index virtual tag
WB	write buffer
WDT	watchdog timer

ACRONYM	DEFINITION
WMA	Windows Media Audio
WMV	Windows Media Video

PRODUCT PREVIEW

7 Mechanical Data

7.1 Ball Grid Array Mechanical Data

GZG (S-PBGA-N289)

PLASTIC BALL GRID ARRAY

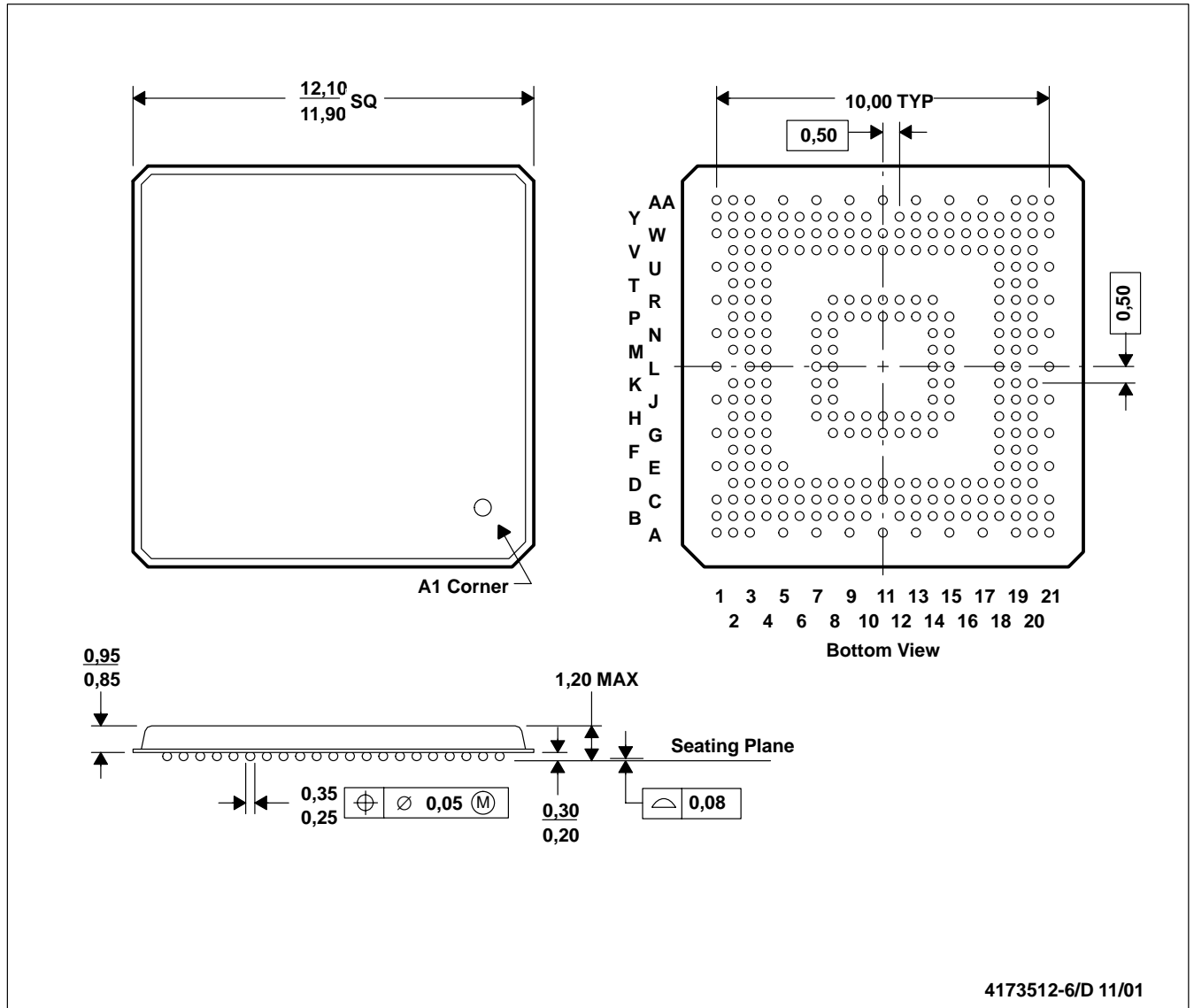

PRODUCT PREVIEW

- NOTES: A. All linear dimensions are in millimeters.
 B. This drawing is subject to change without notice.
 C. MicroStar BGA™ configuration

Figure 7–1. OMAP5910 289-Ball MicroStar BGA™ Plastic Ball Grid Array (GZG) Package

MicroStar BGA is a trademark of Texas Instruments.