

無線網路多媒體系統

Wireless Multimedia System

Lecture 7: Network Mobility

吳曉光博士

<http://wmlab.csie.ncu.edu.tw/wms>

We
provide
無線網路多媒體實驗室
Wireless
Wireless Network & Multimedia Laboratory
Solution

A IP reference Architecture for Wireless Mobile System

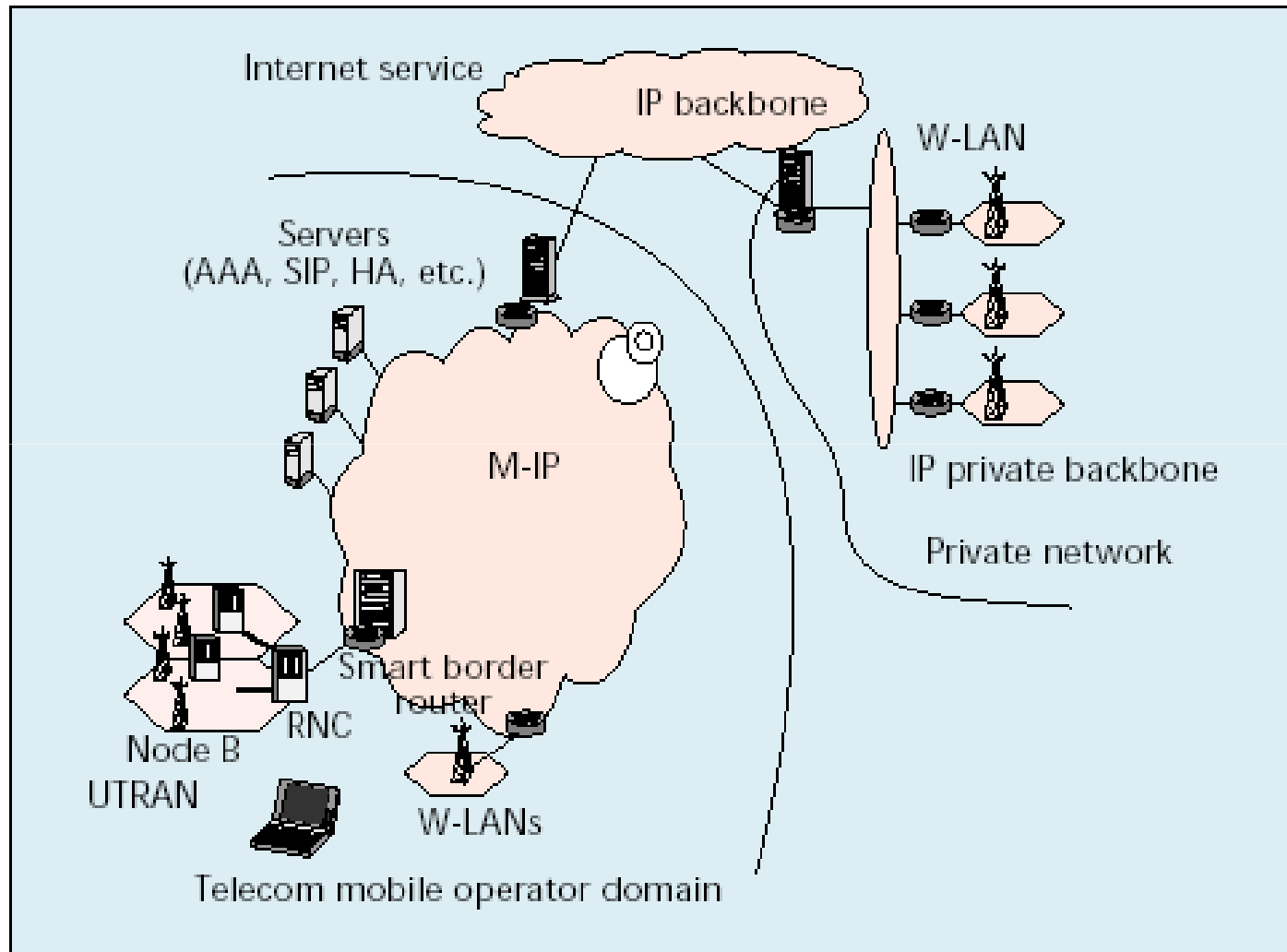

Agenda

- ◆ All-IP System: Beyond 3G

- ◆ Evolutions of PCS

- ◆ ALL IP Challenges
 - Mobile IP/Cellular IP
 - QoS Provisions: Integrated Service / DiffServ

- ◆ Next Week (Wireless TCP)



Reading

- ◆ [Bhagwat96] Pravin Bhagwat, Charles Perkins, and Satish Tripathi, "Network Layer Layer Mobility: An Architecture and Survey"

Foreign Agent Tables

Visitor Table

| Host | HA | Timestamp |
|------|----|-----------|
| | | |
| | | |
| | | |

Home Agent Tables

Away Table

| Host | FA | Timestamp |
|------|----|-----------|
| | | |
| | | |
| | | |

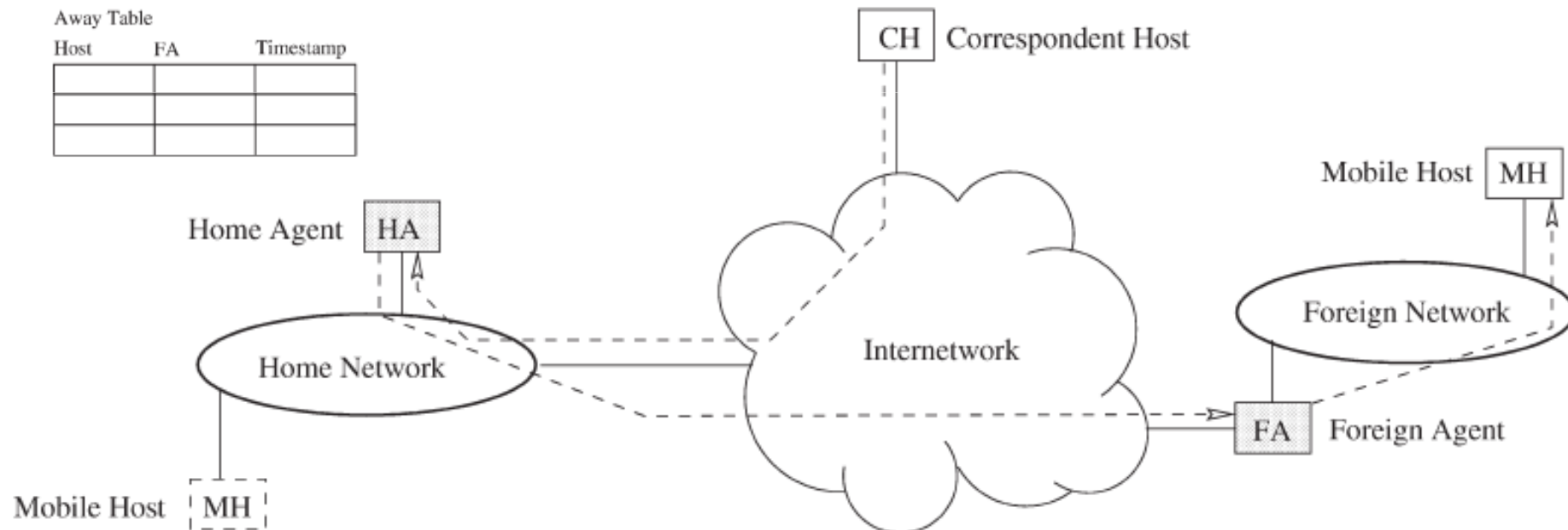

Register Operation

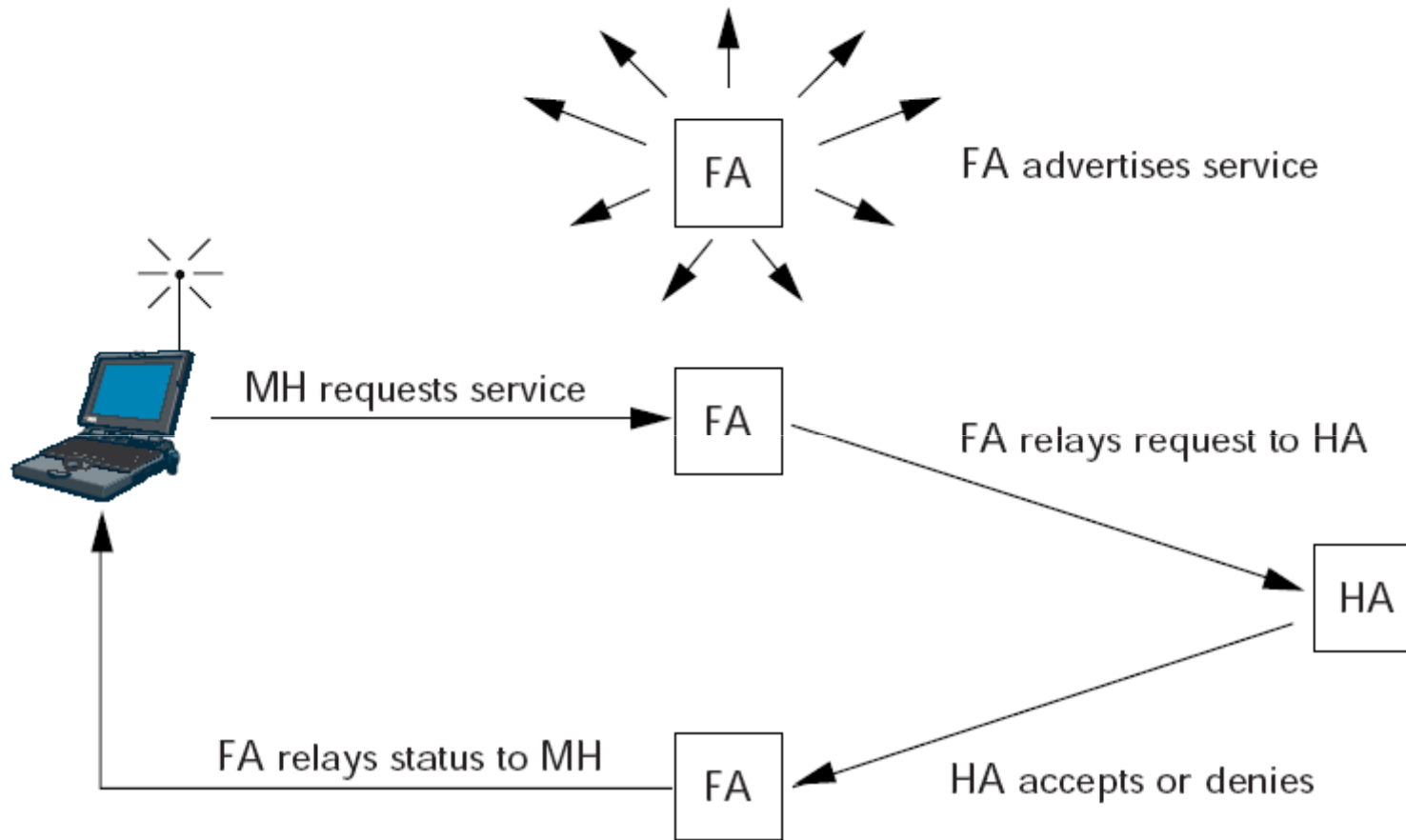

Tunneling Operation

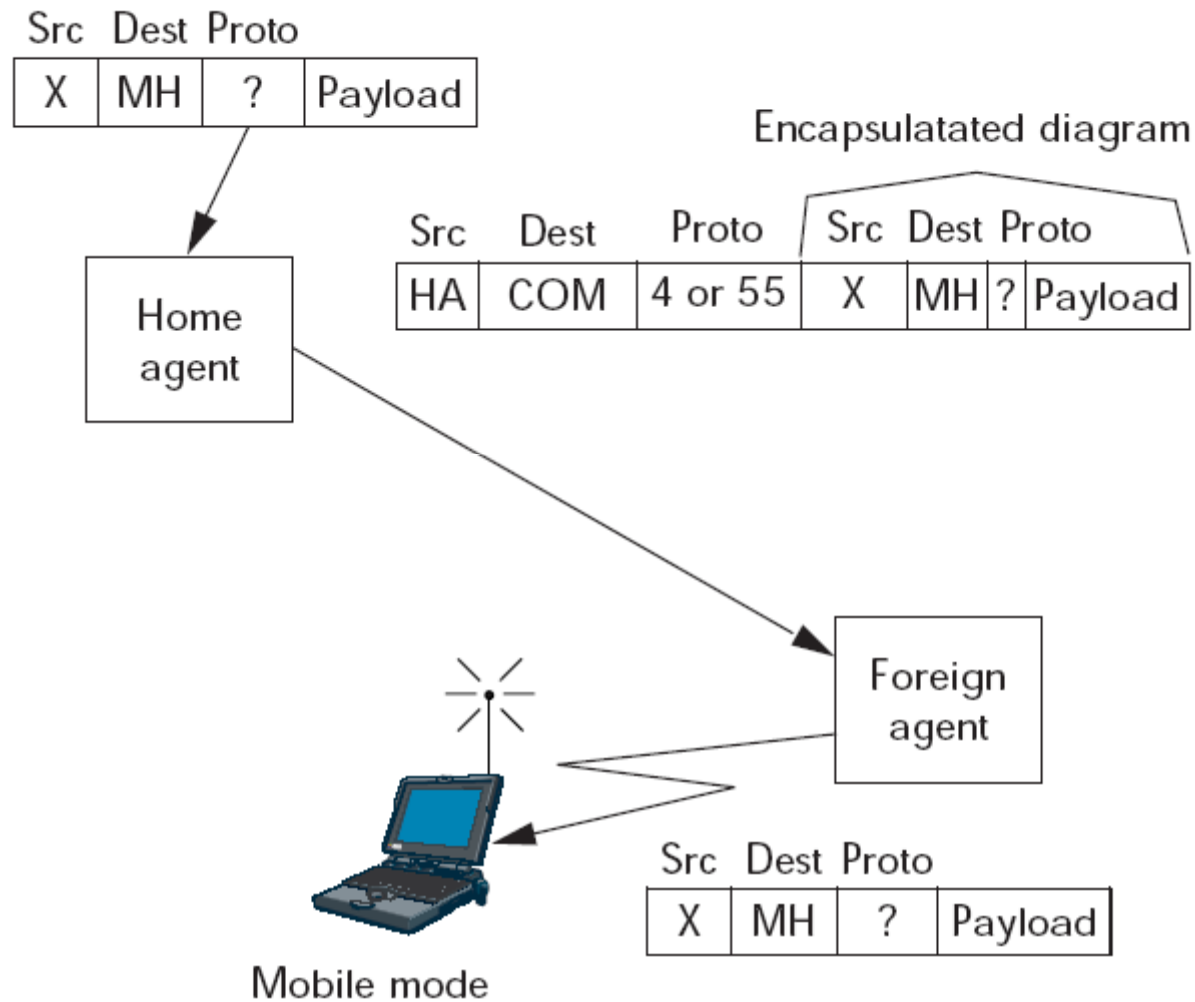

Indirect Routing (Triangular Routing)

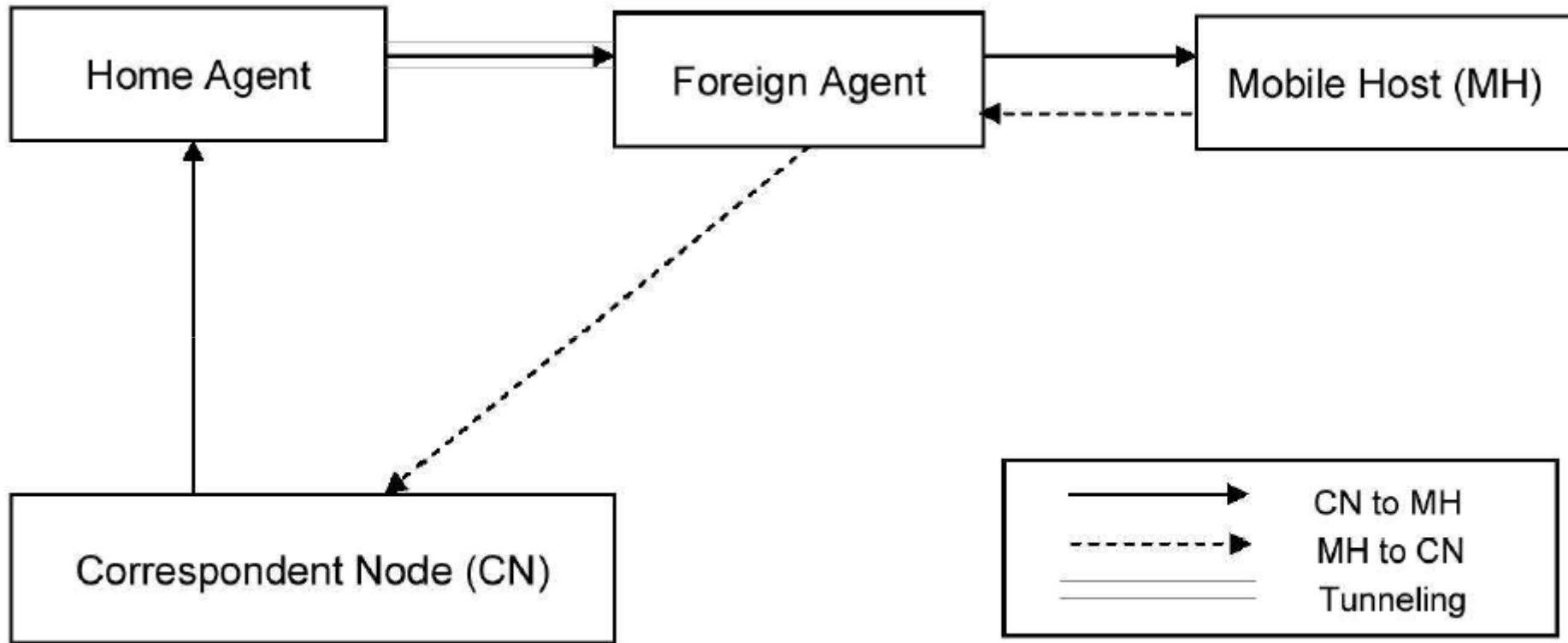

RO (Route Optimization)

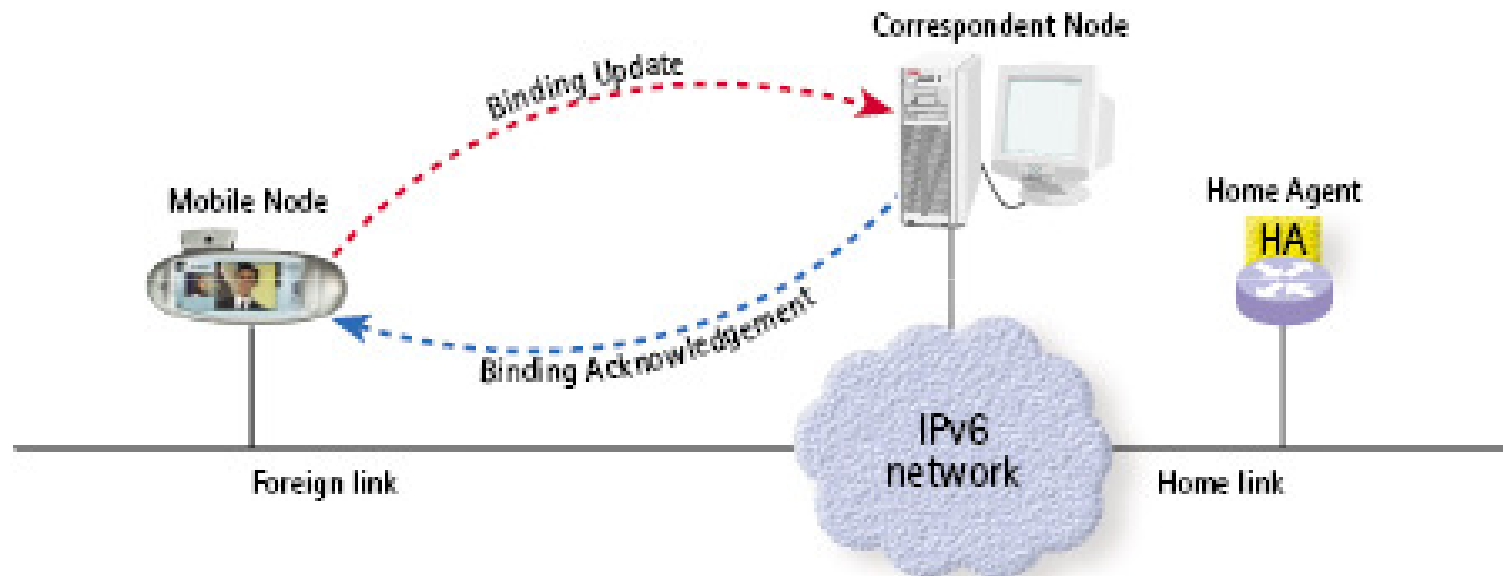

Mobility Management

- ◆ Micro-Mobility

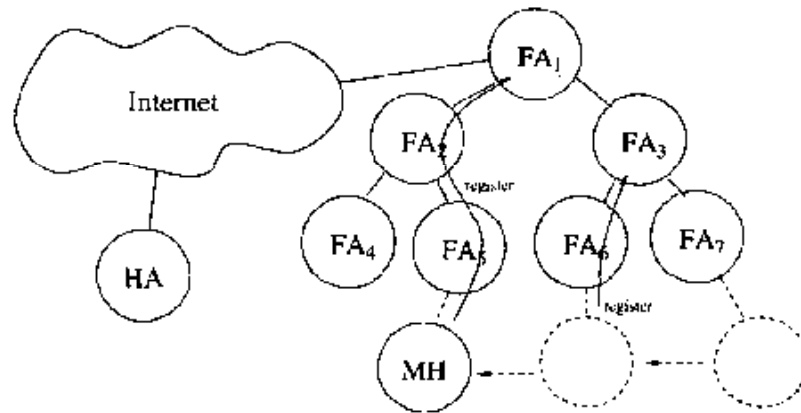

- ◆ Network Mobility

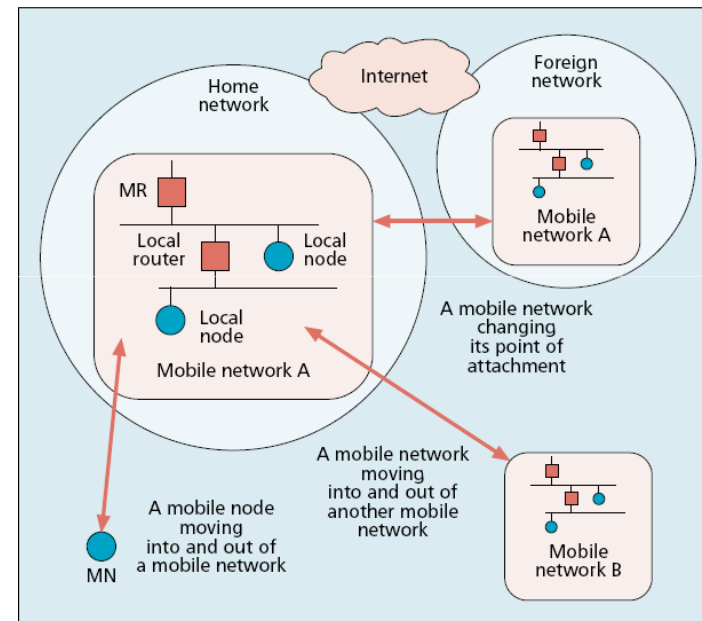

AI IP



Something to happen?

MT Scheduler

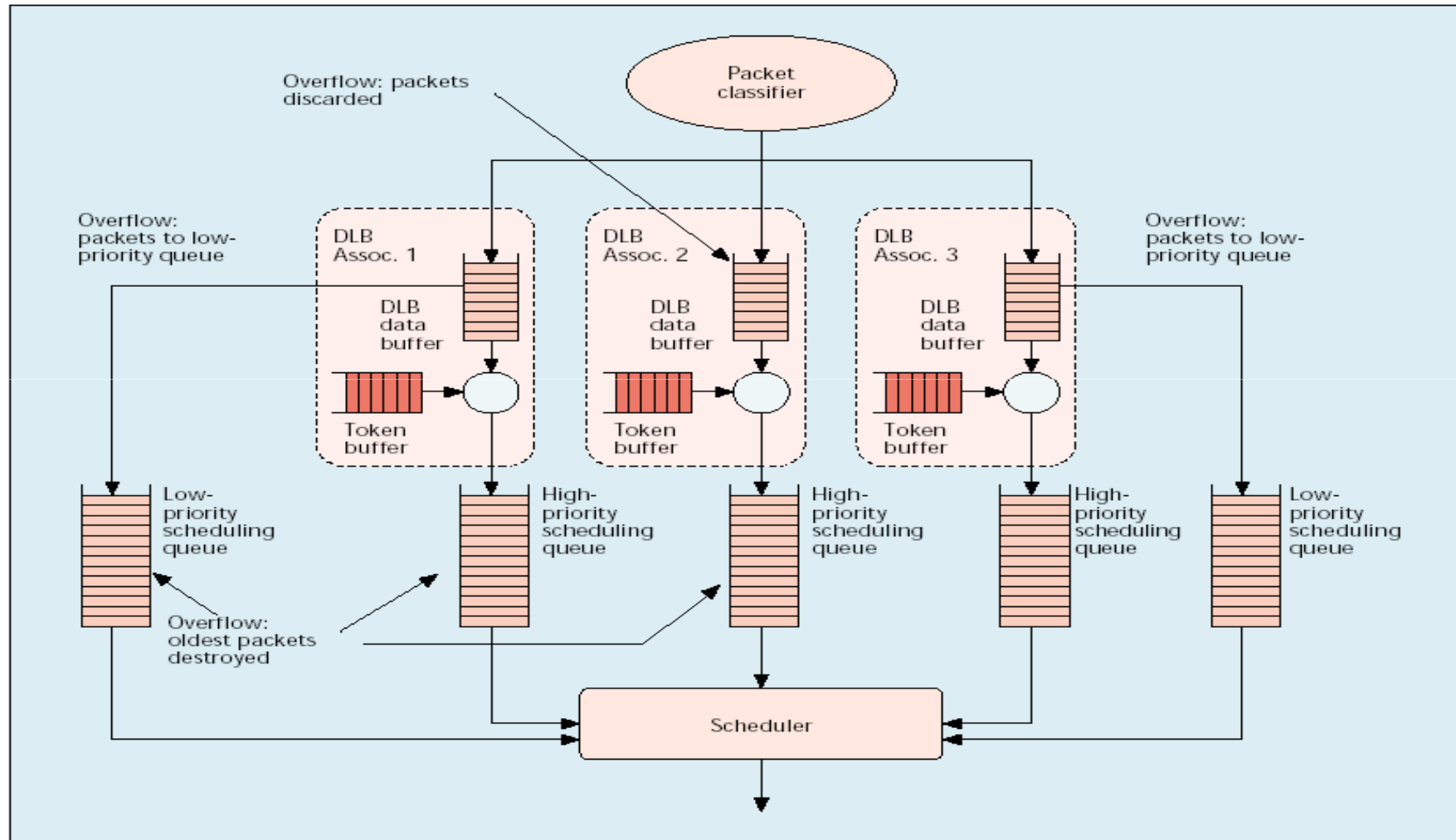

Integration Scenario

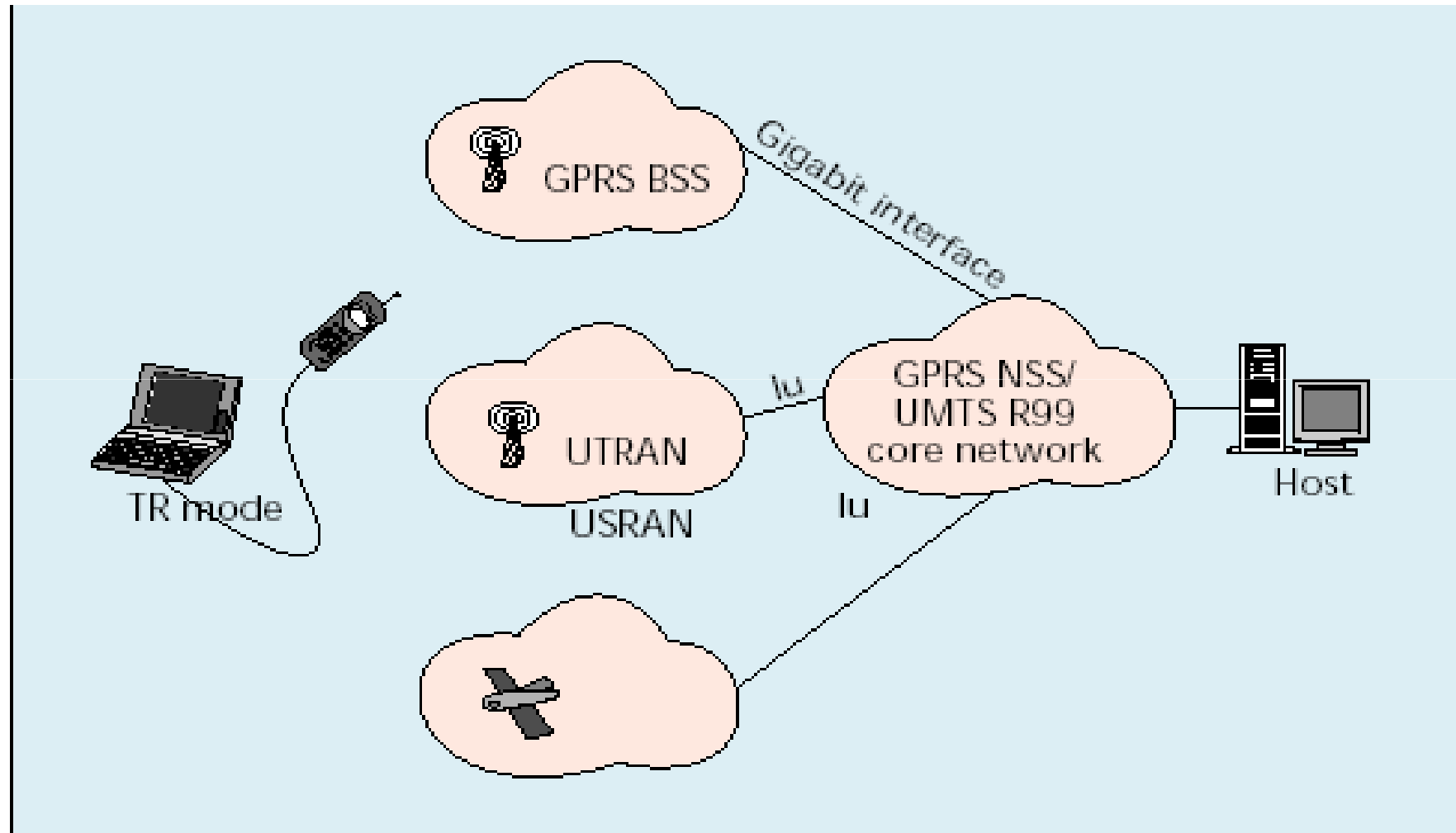

Resource Managements

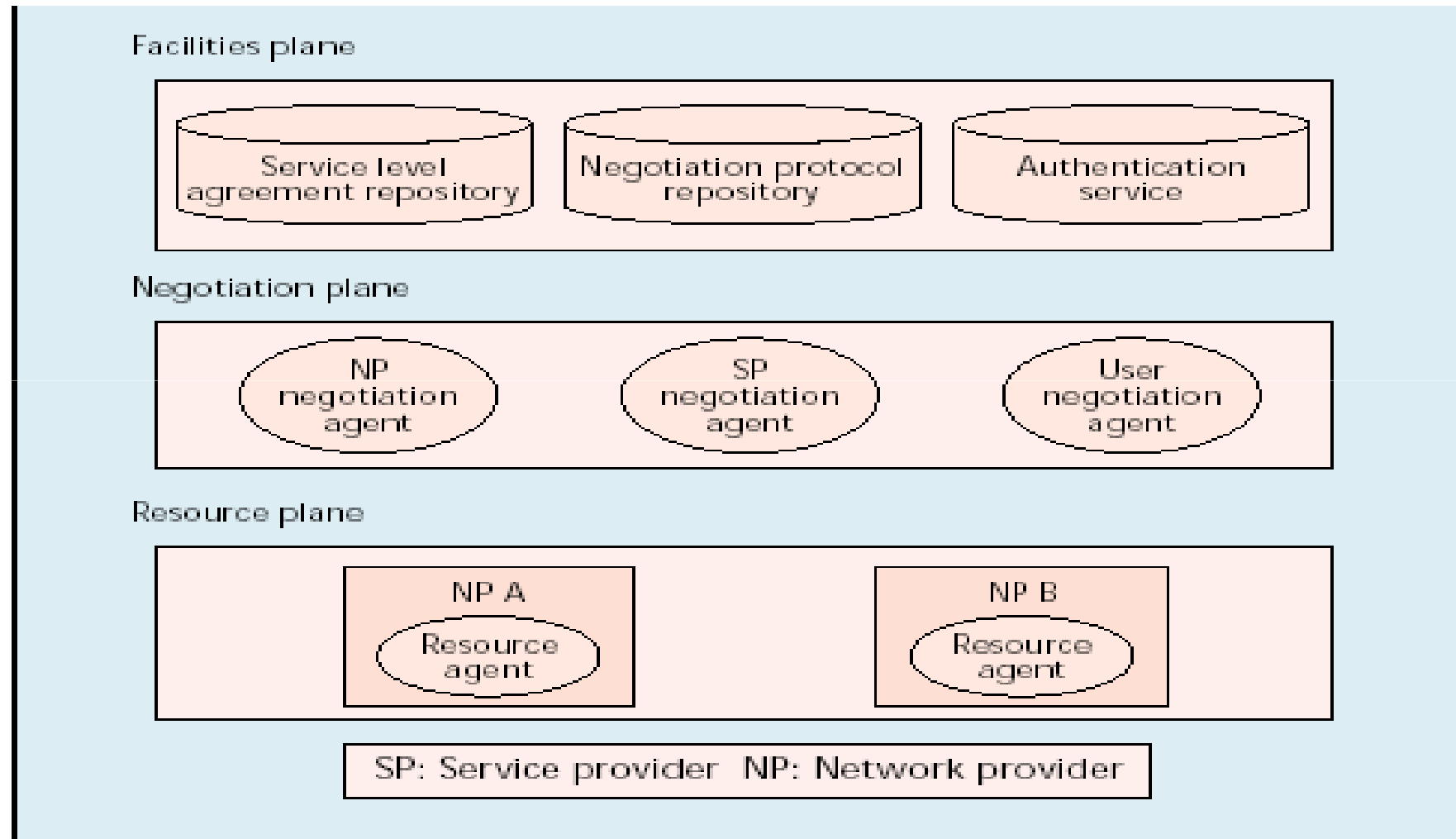

WAL

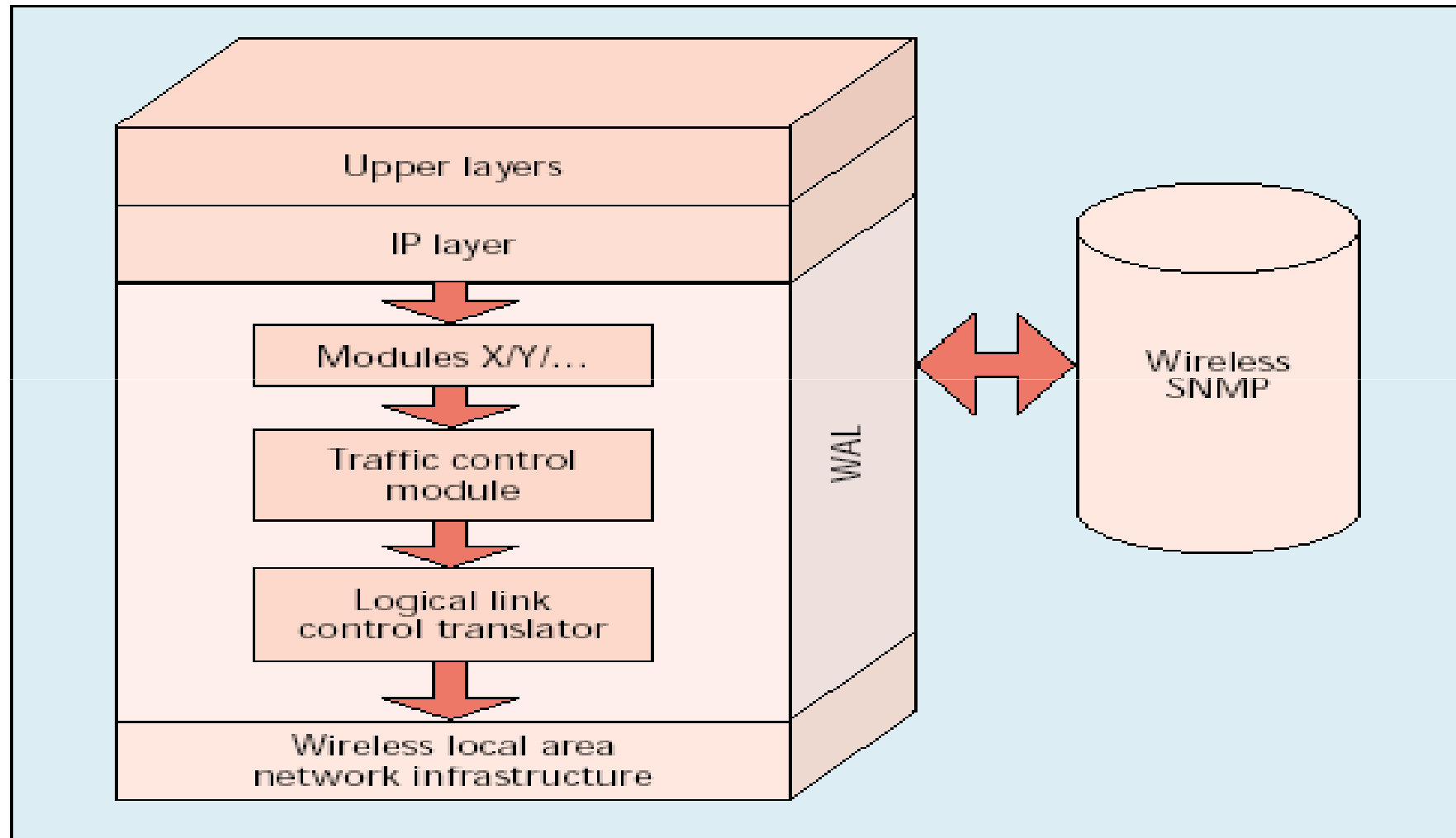

Detail WAL

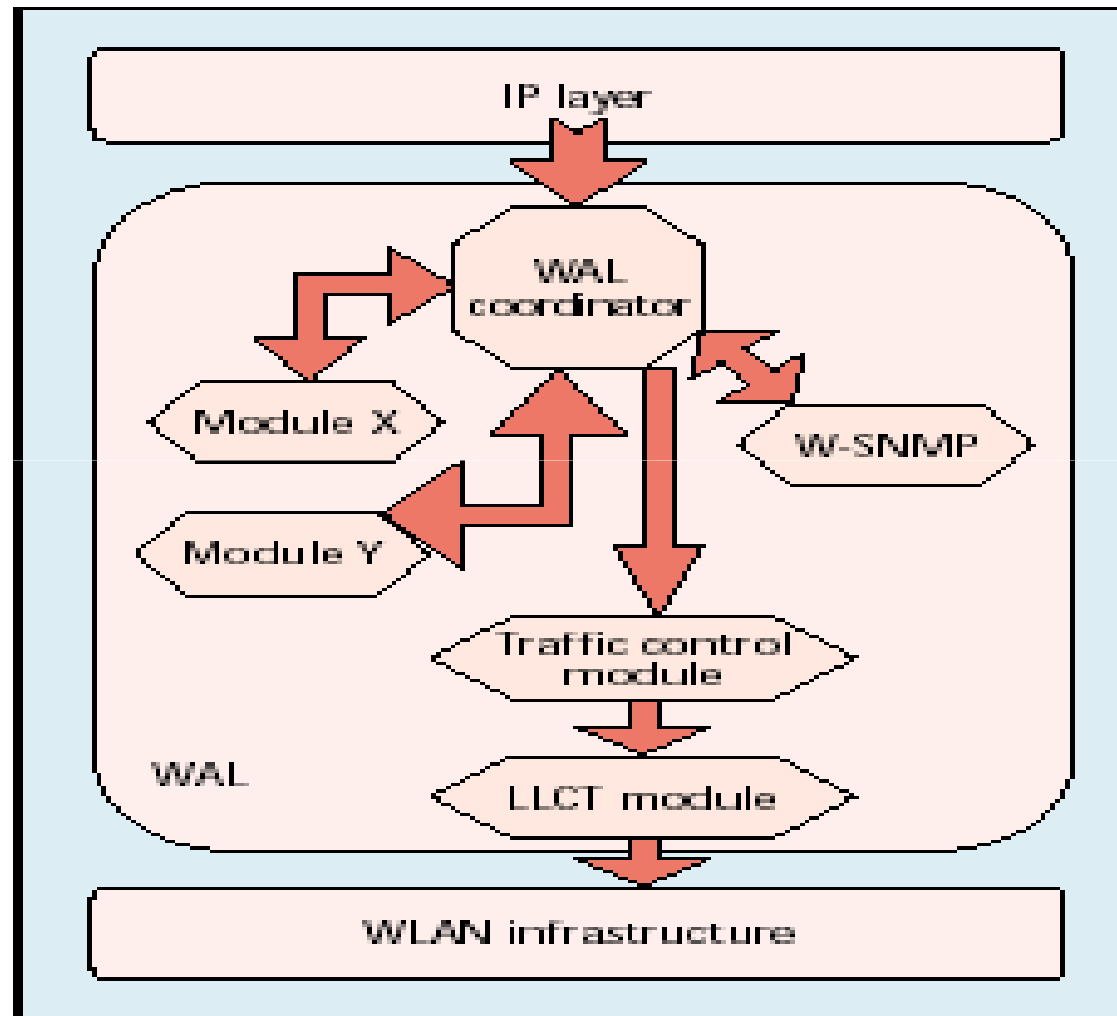

BRAIN

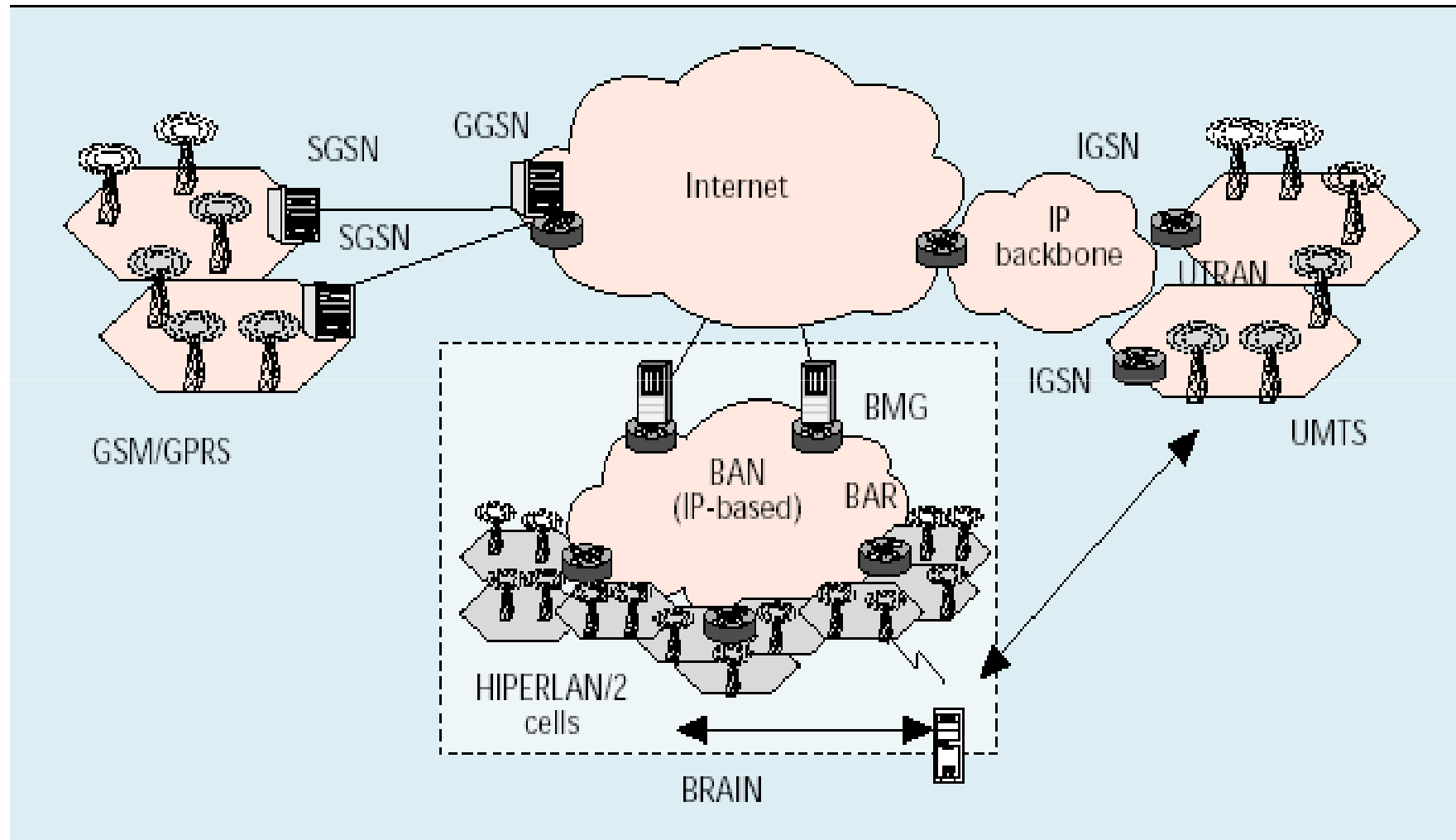

QoS Support

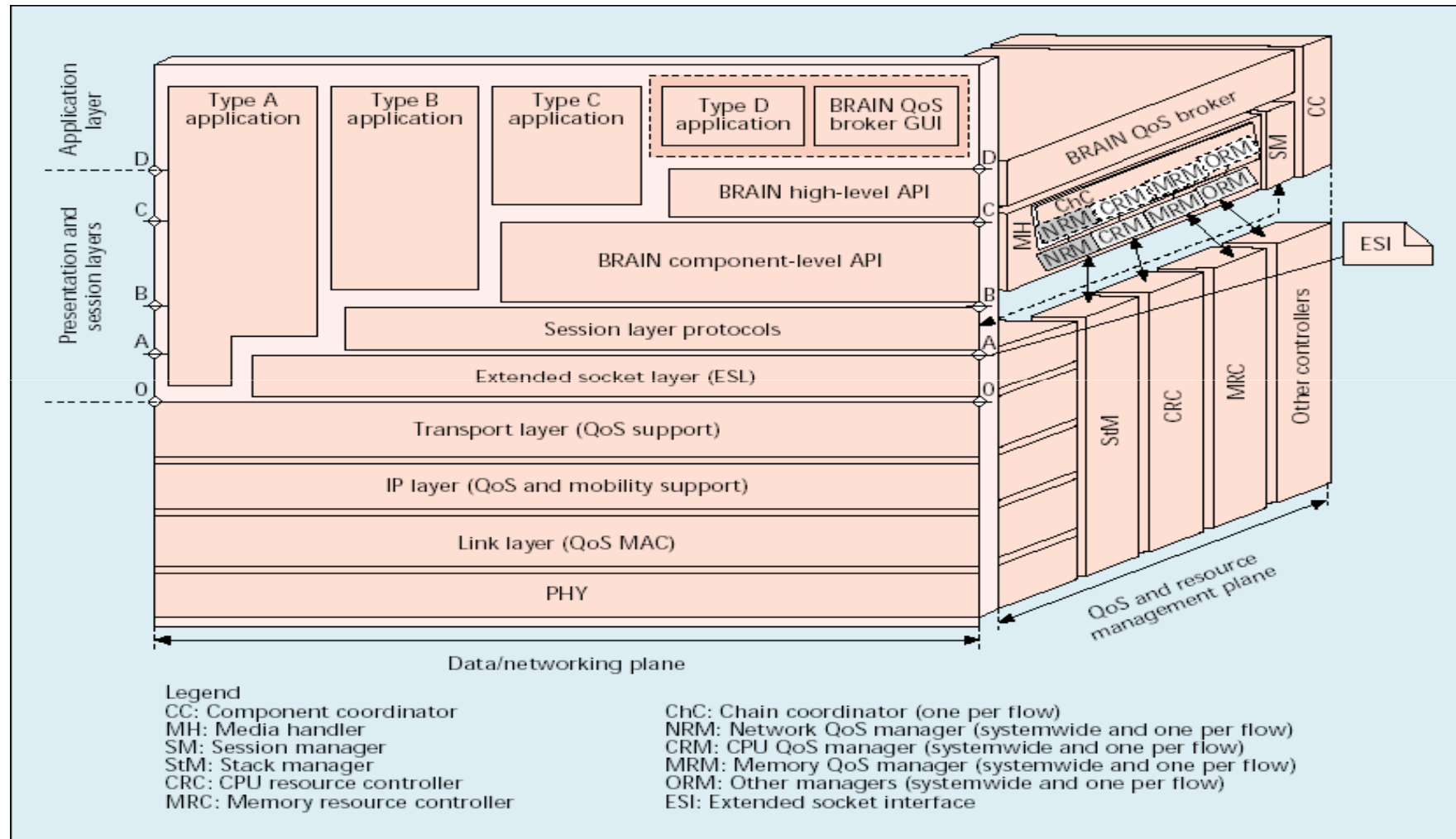

IP QoS Modeling

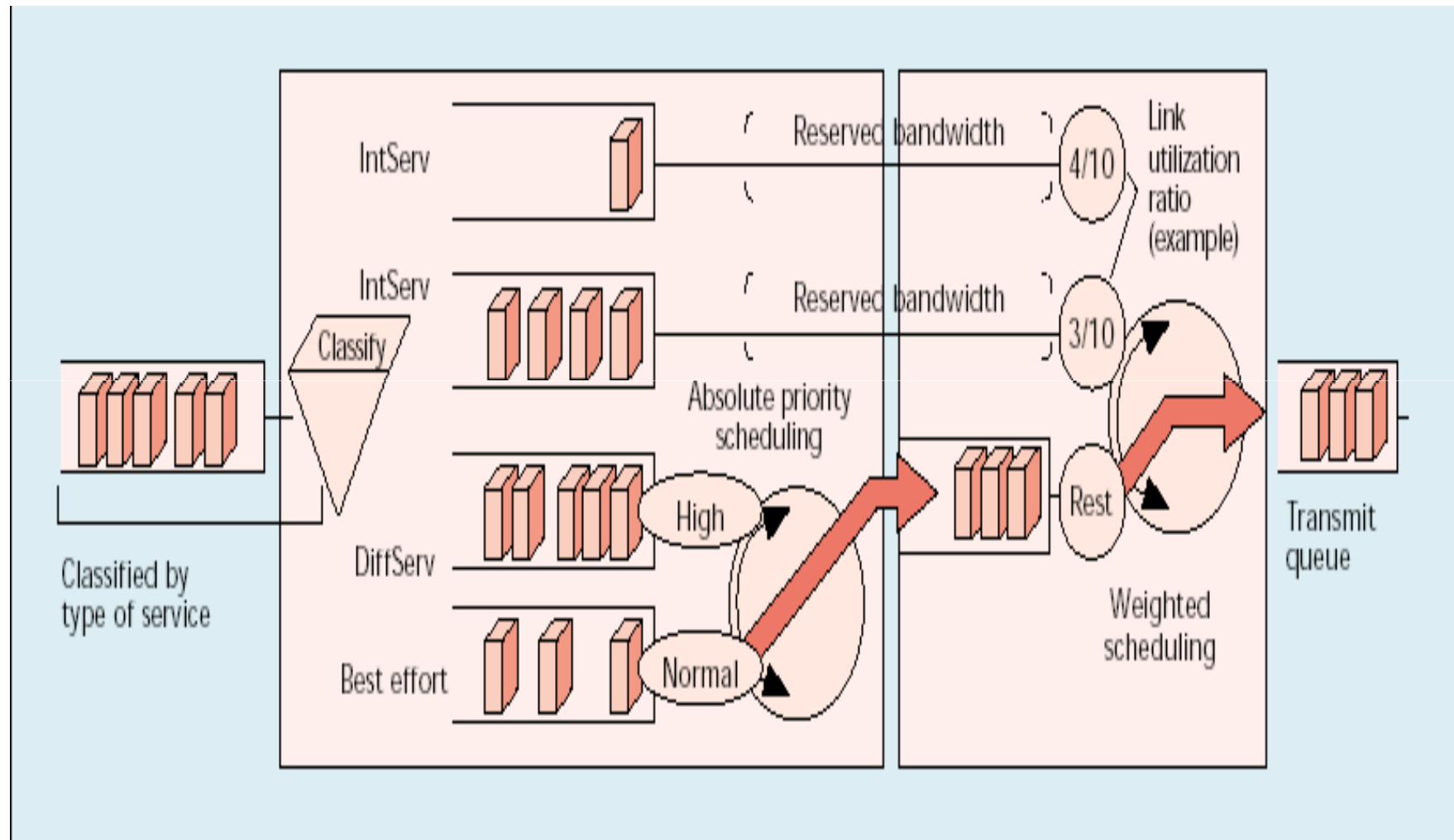

A mobile network in a B3G system

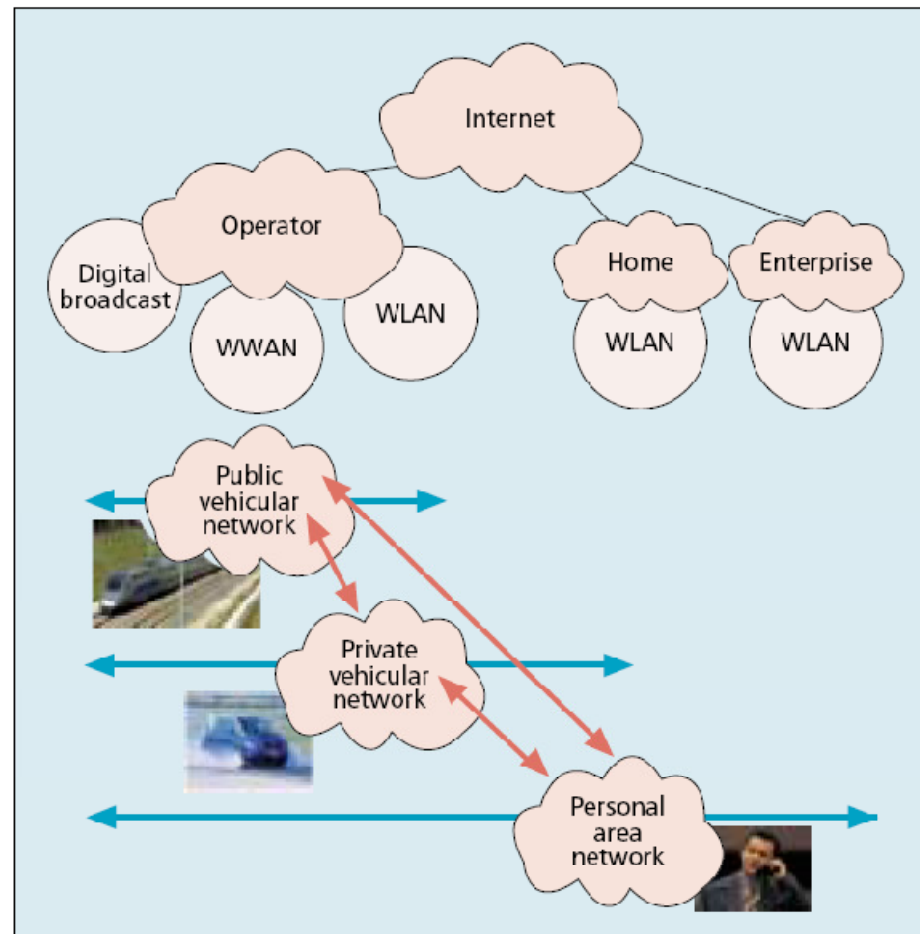

Mobile network scenarios

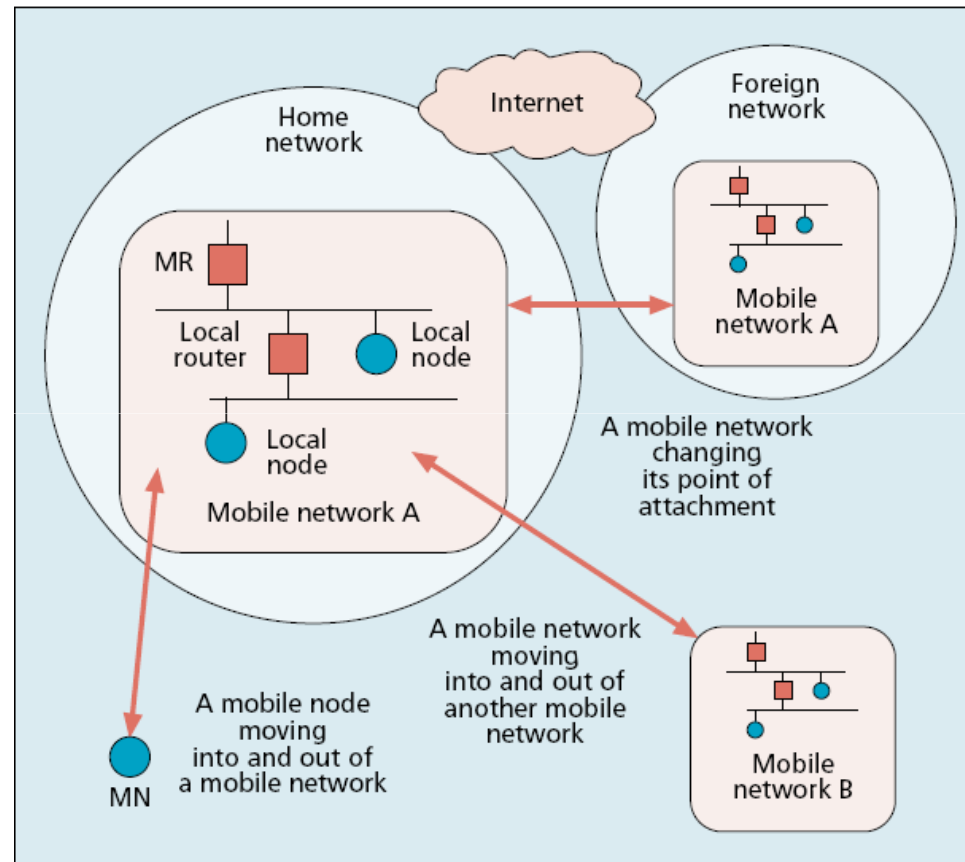

Traffic flows with basic network mobility

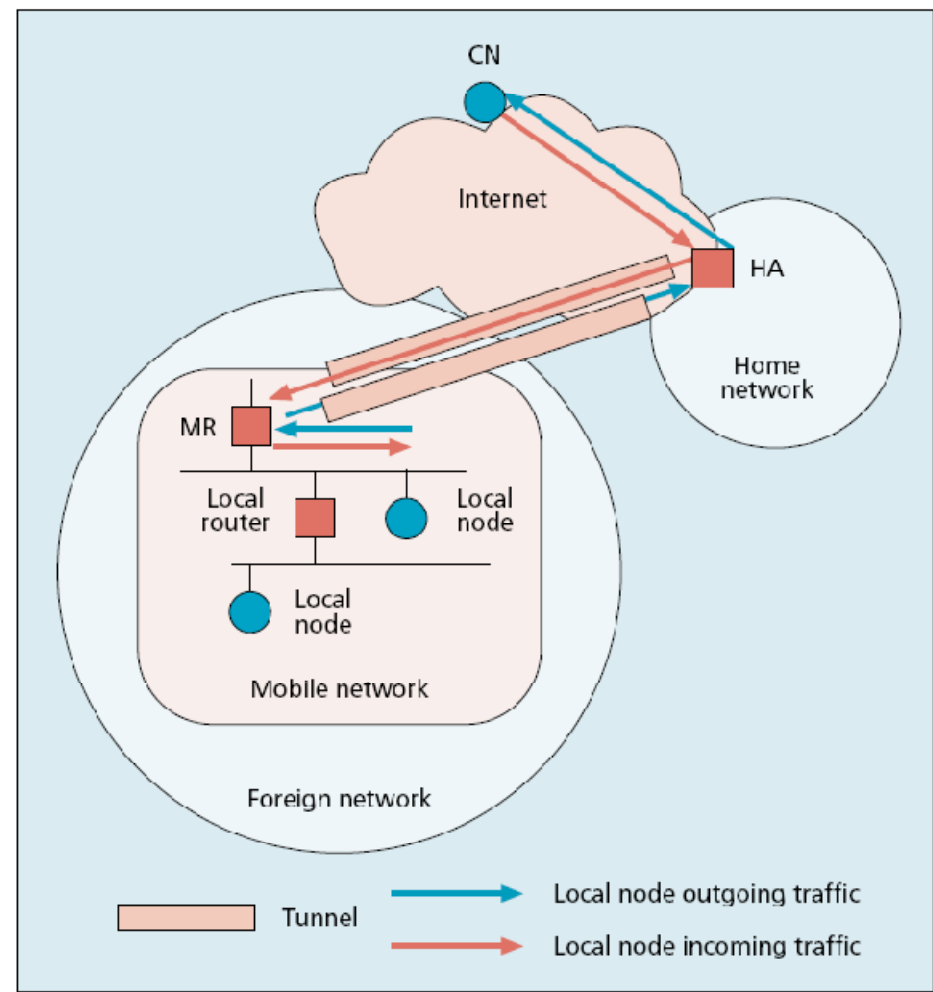

Lecture Outline

- ◆ Mobility in wireless LANs
- ◆ Problems in making Internet mobile
- ◆ Canonical packet forwarding architecture for Mobile-IP
- ◆ Columbia's Mobile-IP schema

Making the Internet Mobile

- ◆ Goal
 - Provide *continuous* IP connectivity to “mobile” users.
- ◆ Mobility == change in how MH accesses the internet
 - Physically move so that access to internet is via a different basestation.
 - Switch network interfaces
- ◆ Continuous connectivity
 - Datagrams for MH must be delivered to its current location
 - Mobility must be transparent to applications
 - ◆ Applications must not die or need to be restarted
 - ◆ Performance transparency also desirable
- ◆ Desirable
 - Secure
 - Work across security domains
 - Require no changes to existing stationary hosts

Mobility in Wireless LANs: Basestation as Bridges

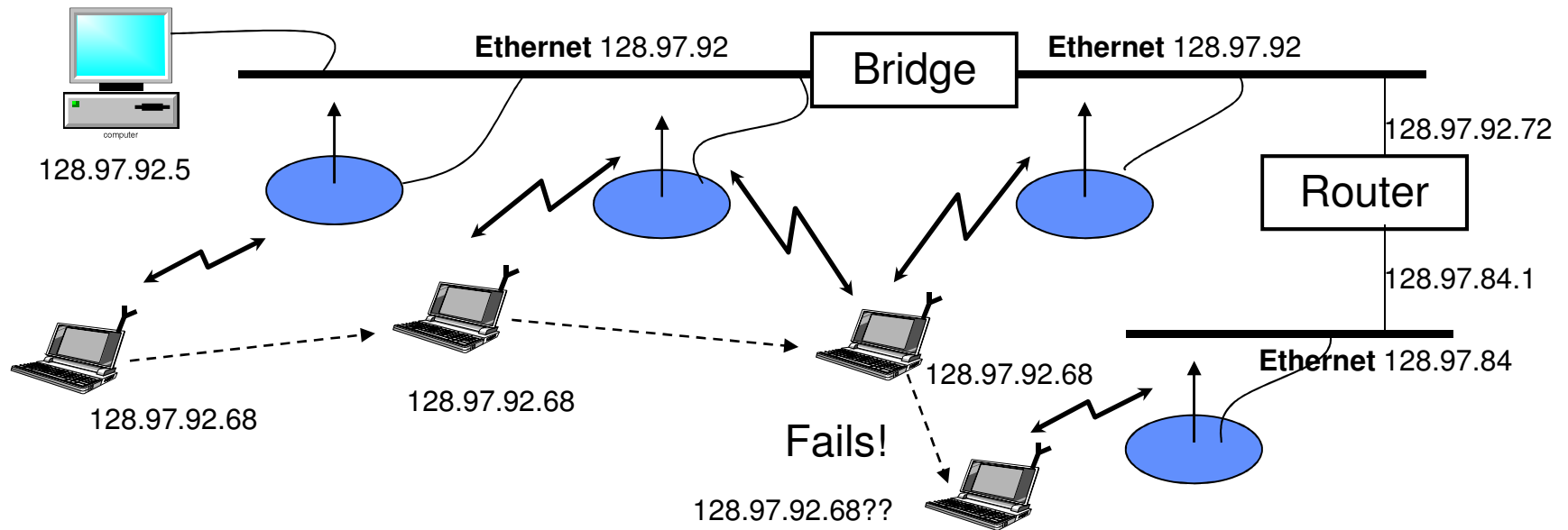

- ◆ Basestations are bridges(layer 2) – i.e. they relay MAC frames
 - Smart bridges avoid wasted bandwidth
- ◆ Works the within an ethernet(or other broadcast LAN)
 - Fails across network boundaries, and in switched LANs(e.g. ATM)

Internet Naming and Addressing

- ◆ Collection of networks that are connected by routers
- ◆ Each internet host(each network interface) has two identifiers:
 - Internet (IP) Address(32-bit)
 - Host Name (string)
 - ◆ Domain Name System (DNS) maps host names to IP address
- ◆ Applications refer to hosts by names
 - Use Domain Name System (DNS) to map host names to IP addresses
 - ◆ DNS lookup done once only at connection set-up
 - Transport protocols developed that assume this static binding
 - ◆ E.g. a TCP connection is identified by
 - *<Source IP address, source TCP port, destination IP address, destination TCP port>*
- ◆ Packets carry source and destination IP addresses
 - Routers use routing tables to forward packets based on destination address
 - Packet sent directly to destination within a network (e.g. ethernet)

DNS-based Resolution

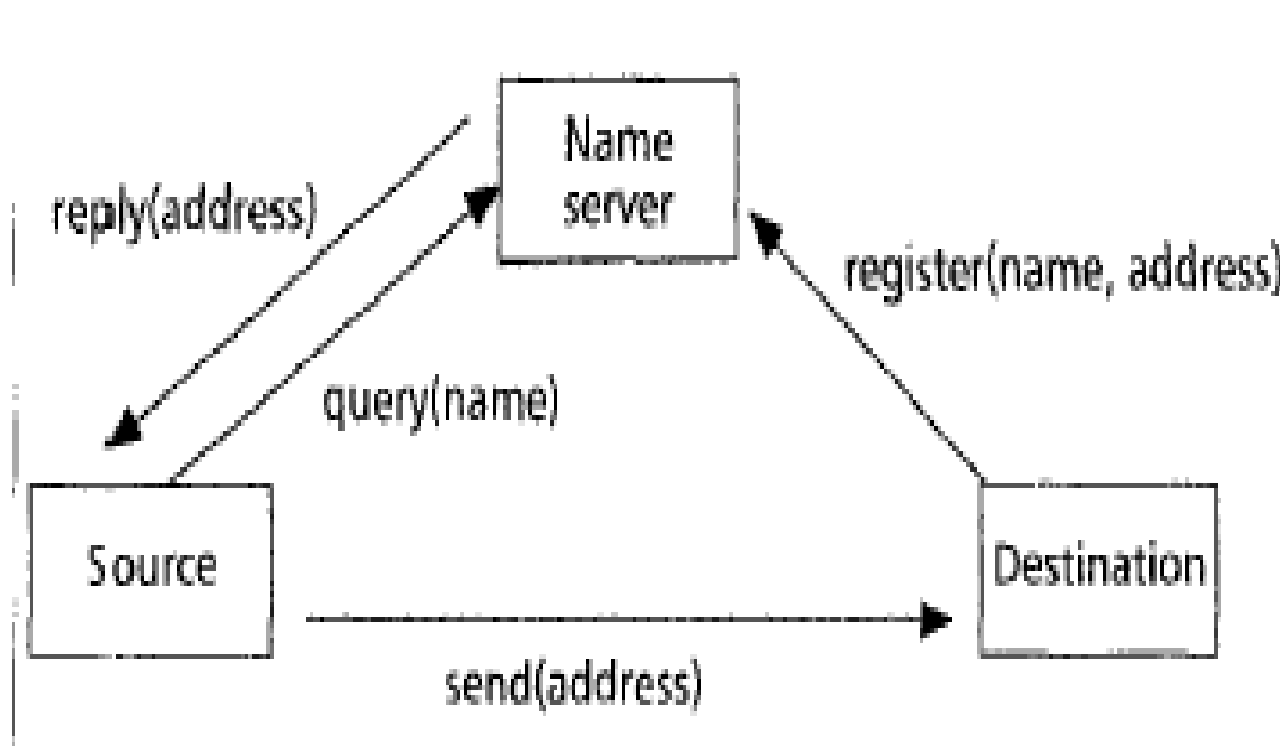

Hierarchical Addressing

- ◆ Routers maintain network topology in routing tables
- ◆ Flat IP address space would make routing tables huge!
 - Many many millions of hosts
- ◆ IP address space is therefore *hierachical*
 - IP address is a tuple: (*network id*, *host id*)
 - e.g., consider 192.11.35.53

| Network id | | | Host id |
|------------|----|----|---------|
| 192 | 11 | 35 | 53 |

- ◆ Internet routers required to maintain network topology only at the granularity of individual networks
 - Only network id part of destination address used in routing
 - Makes routing tables manageable

Key Observation: IP address serves two purposes!



- ◆ Endpoint identifier for transport and application layer
 - MH's IP address must be preserved to retain transport-layer sessions
 - ◆ All TCP connections would die if MH acquires a new IP address
- ◆ Routing directive for network layer
 - MH's IP address must be changed for hierarchical routing to work!
 - ◆ Packets will continue to get routed to the old network
 - ◆ DNS entry will also need to be changed

What should on do?

This is the primary problem in making Internet mobile!

“Non-solutions” to Internet Mobility

- ◆ Enhance DNS
 - Historically, DNS does not have dynamic *name-address binding* updates
 - ◆ Optimized for access cost
 - ◆ DNS clients cache DNS records
 - ◆ Hard to optimize for both access and update costs
 - Solves only part of the problem
 - ◆ TCP connections will still die!
- ◆ Keep per-MH routing information at all routers
 - Completely breaks the hierarchical routing model
 - Unbounded growth in routing table sizes at all routers
- ◆ Fix all the transport layer and higher protocols, and applications
 - Yeah, sure.....

Clean solutions: fix the network (IP) layer!

Making IP Network Layer Mobile

•Challenge of Mobile-IP

How to direct IP packets to MH that travels to a Foreign Network away from MH's Home Network?

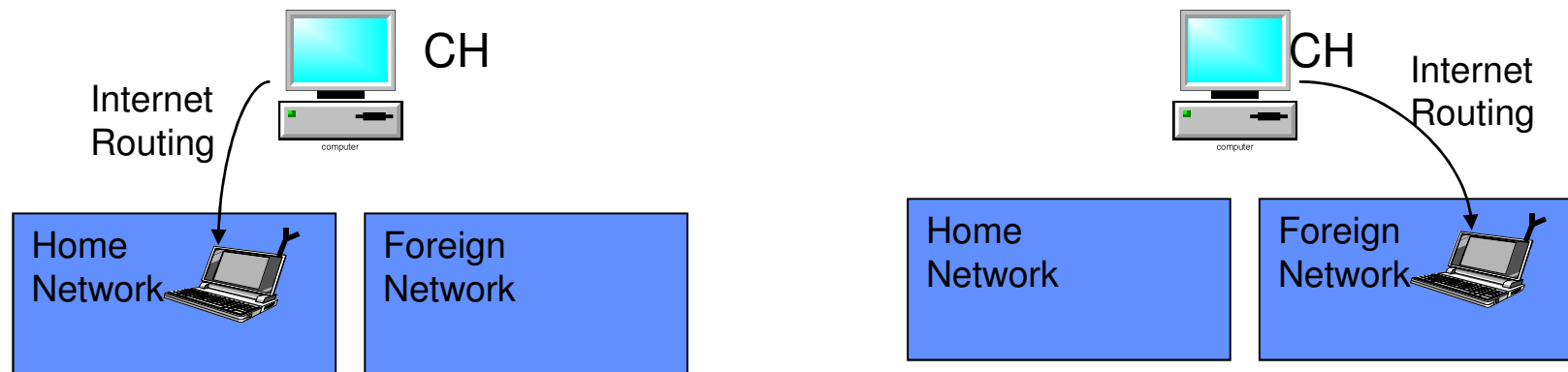

- ◆ MH is assigned a home address as its IP address
 - Home network is the network containing the home address
 - DNS queries for MH return the home address
- ◆ Mobile-IP only concerned with moves across networks
 - Moves within home network (e.g. ethernet) handled by link-layer bridging.

Illustration of terms

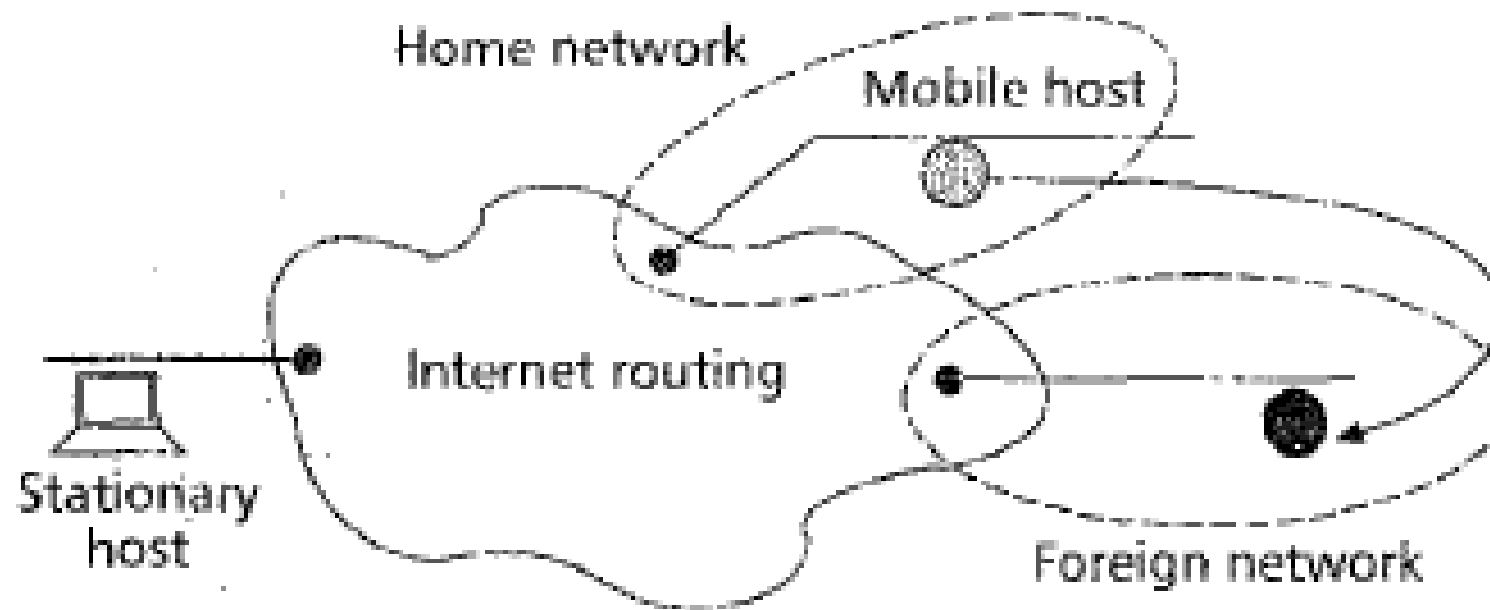

Key to Mobile-IP Two-Tier Addressing

- ◆ MH has two IP addresses associated with it
 - Does not mean two IP addresses are assigned!
- ◆ First component of the address serves as the routing directive
 - Reflects MH's point of attachment to Internet
 - ◆ Derived from the foreign network
 - Changes whenever MH moves to a new network
 - Internet routers use this address to route to MH's point of attachment
- ◆ Second component of the address serves as the end-point identifier
 - This is the home address
 - Remains static throughout the lifetime of MH
 - Only this address used for protocol processing above network layer
 - ◆ MH remains virtually connected to the home network
- ◆ Two-tier addressing is only a logical concept
 - IP packet headers can't actually carry two addresses!
- ◆ MH to Stationary Host (SH) packets do not need special handling

Two-Tier Addressing for Mobile Hosts

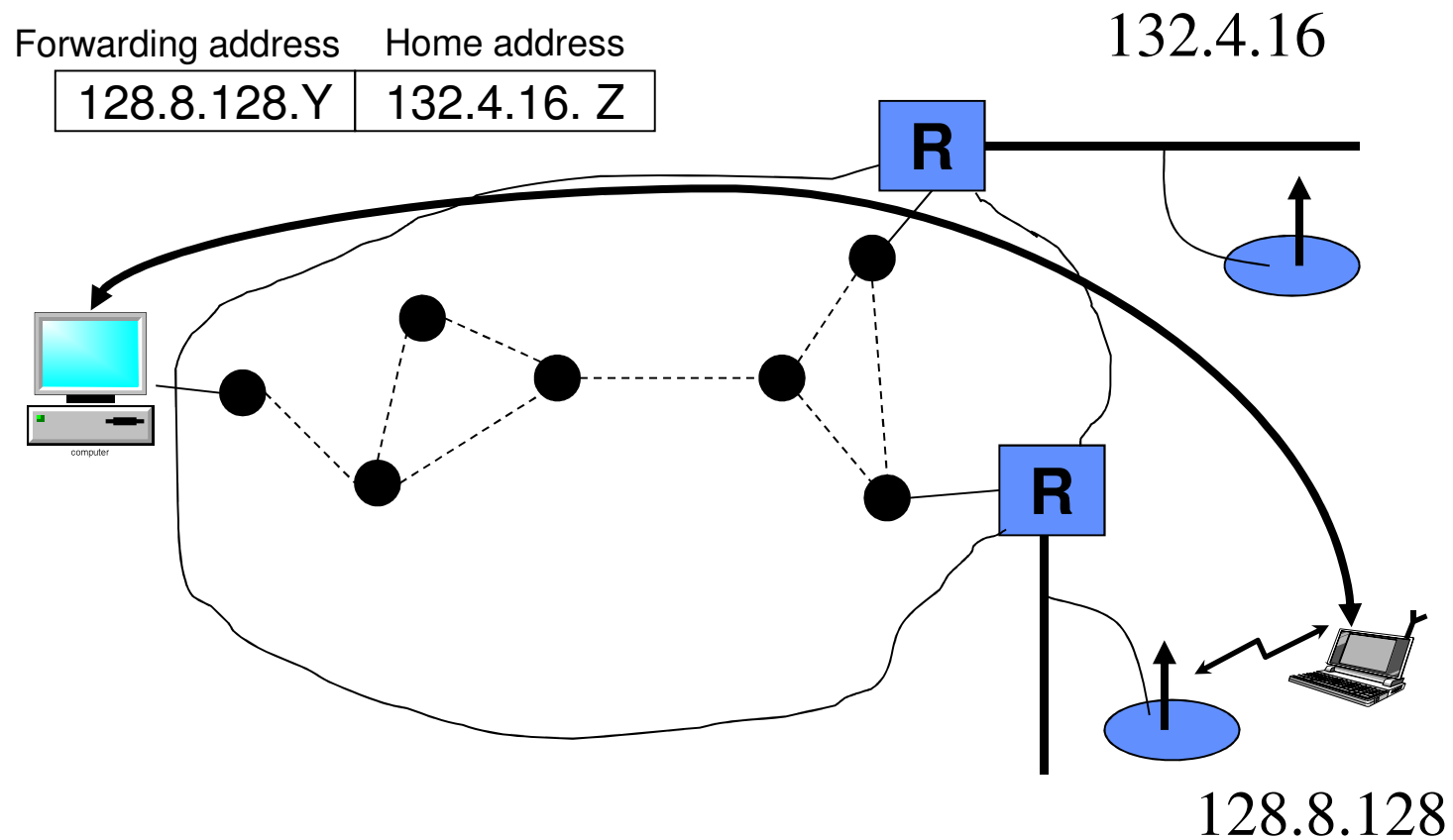

Typical Example

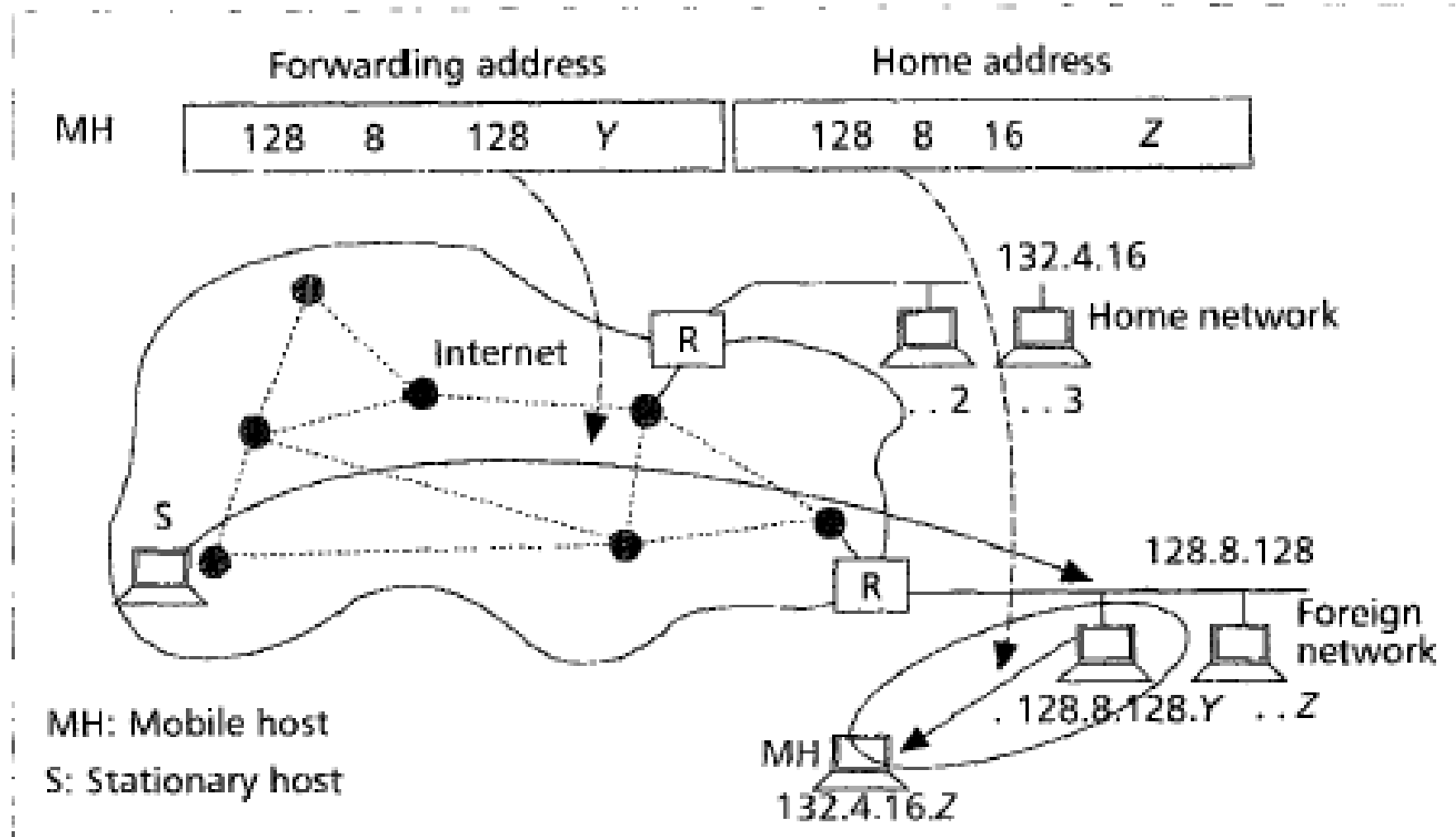

Packet Forwarding model

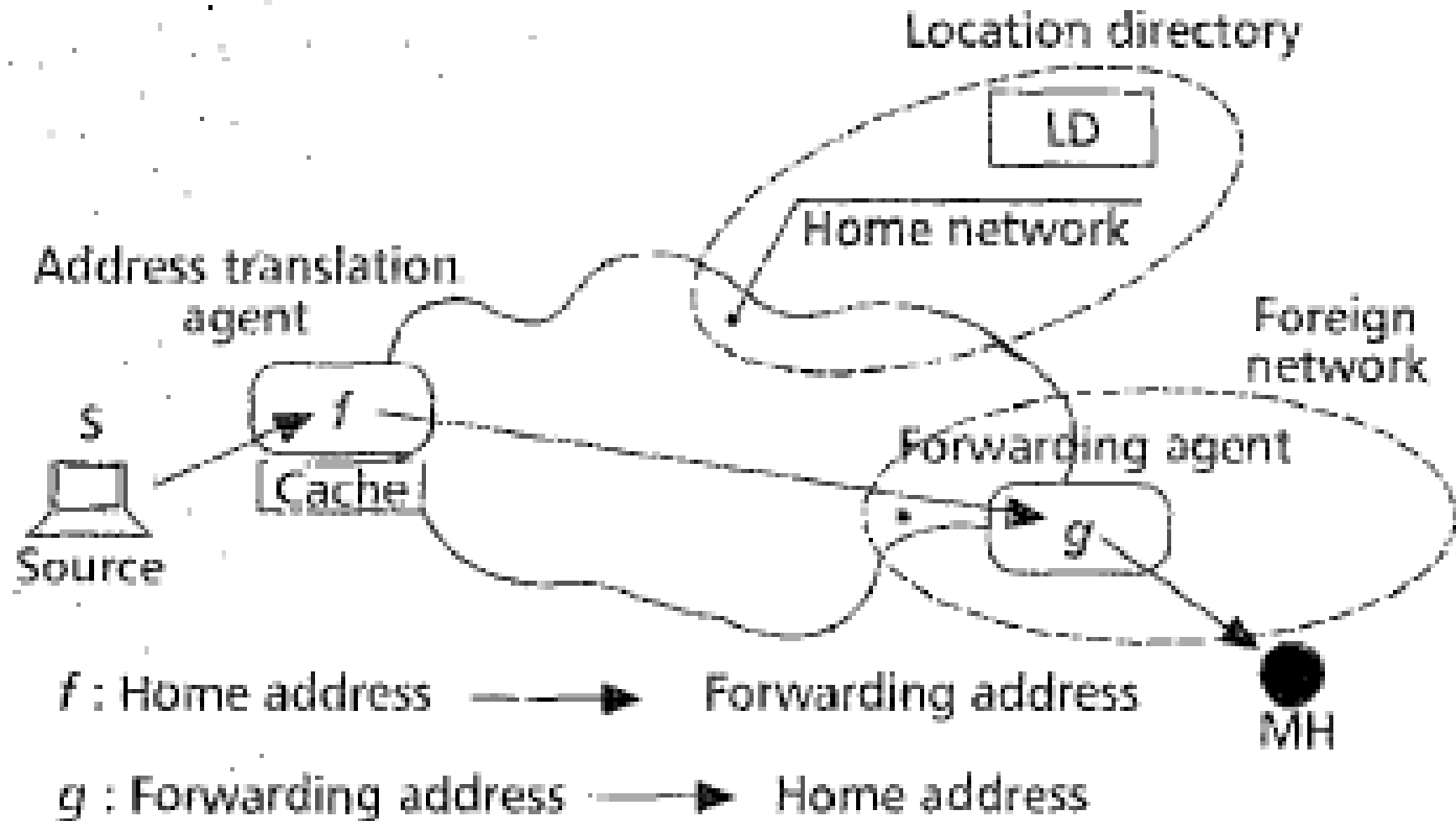

Canonical Mobile-IP Architecture

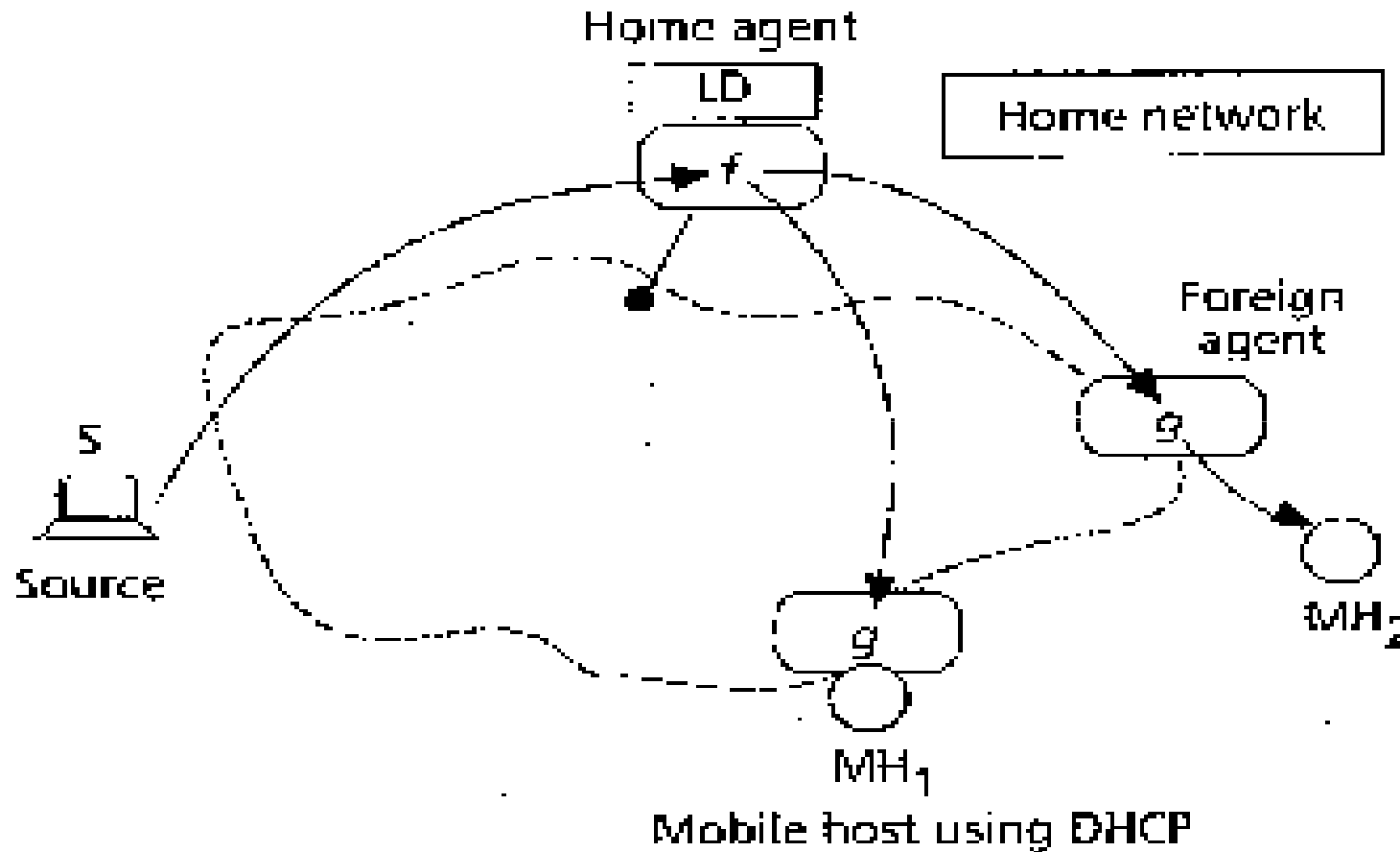

Components of Canonical Mobile-IP Architecture



- ◆ Forwarding Agent (FA)
 - Forwarding component of two-tier address is the address of FA entity
 - FA receives packets on behalf of MH
 - ◆ Packets contain FA's address as destination
 - FA maps forwarding address to MH's home address
 - ◆ FA: $g(\text{forwarding address}) \rightarrow \text{home address}$
 - FA then relays the packet to MH
 - FA represents a function, not a machine

Issues:

- Where can FA be located?
 - ◆ MH, BS, somewhere else
- How does MH find the FA in a foreign network? (and, vice versa)
 - ◆ Route advertisement and registration protocol
 - ◆ FA periodically advertises its presence (beacons)

Component of Canonical Mobile-IP Architecture (contd.)



- ◆ Location Directory (LD)
 - Records association between home and forwarding addresses
 - ◆ Contains most up to date mapping of MH to its FA
 - MH sends updates to LD on moving
 - Issues:
 - Centralized vs. distributed realization
 - ◆ Centralized is infeasible – too many MHs in the Internet
 - How to distribute?
 - ◆ Cost operation
 - ◆ Security
 - ◆ Ease of location
 - ◆ Ownership
 - Possible distribution policy: *owner-maintains*
 - ◆ Some agent in home network maintains LD information for a MH responsible for security, authentication, updates, and distribution
 - ◆ a CH does not need to find the right LD component to query router in home network can forward to the correct LD component

Component of Canonical Mobile-IP Architecture (contd.)



- ◆ Address Translation Agent (ATA)
 - CH sends packets to MH at its home address
 - ATA replaces MH's home address with FA's address in packets
 - ◆ $ATA: f(\text{home address}) \rightarrow \text{forwarding address}$
 - address translation involves:
 - ◆ Querying the LD
 - ◆ Obtain address of the FA corresponding to the MH
 - ◆ Use FA's address to forward packet to MH's location
 - Issues:
 - ◆ Where to locate ATA
 - At CH: but will need to change software in millions of hosts! elsewhere
 - ◆ Querying LD for every packet is expensive: cache LD entries?
 - Improves performance
 - but, requires maintaining consistency between LD and cached entries!

Location Update Protocol (LUP)

- ◆ LUP is the reliable mechanism for
 - Keeping LD up to date
 - Keeping cached LD entries consistent with master LD
- ◆ Choice of LUP depends on caching policy
 - Together they determine scalability and routing characteristics
- ◆ What if no LD caching
 - ATA must be collocated with LD to avoid per-packet queries
 - Packets from CH will first travel to home network before being sent to FA no optimal paths!
- ◆ What if there is caching?
 - Routing efficiency is improved no more travel to home network
 - but, vulnerable to security attacks cache updates must be authenticated otherwise, traffic to MH may be redirected away!

Address Translation Mechanisms

- ◆ Encapsulation approach (IP-in-IP tunnel)
 - ATA appends new header at the beginning of datagram
 - Outer header contains the forwarding address
 - Inner header contains the home address
 - Internet routes according to outer header
 - FA strips the outer header and delivers datagram locally to MH



ATM (Address Translation Mechanisms)

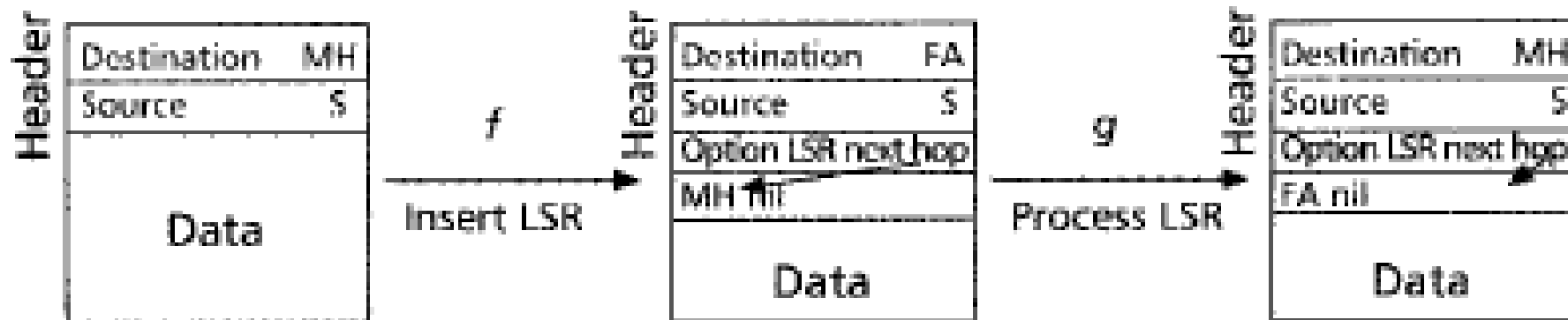
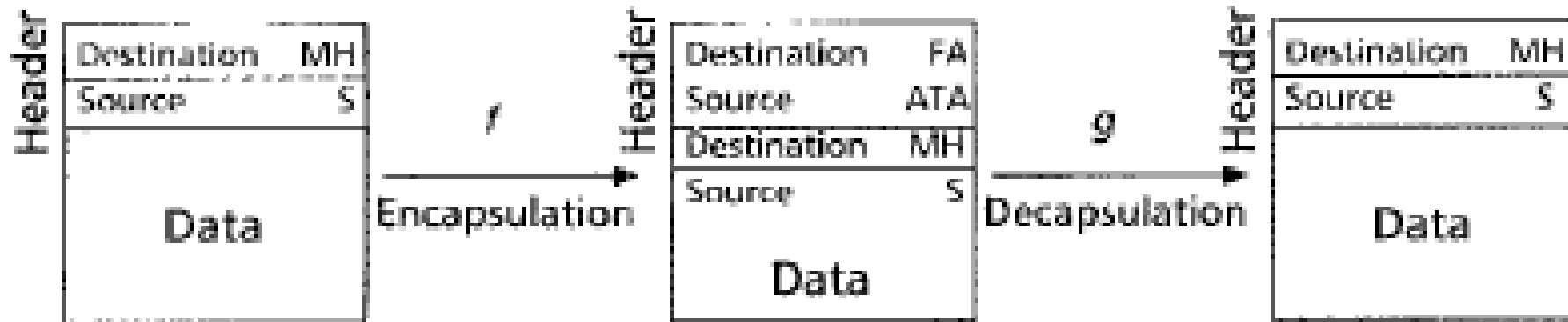

Address Translation Mechanisms (contd.)

- ◆ Loose Source Routing approach
 - Option in IP packets to specify a sequence of IP addresses to follow path is automatically recorded in the packet destination can send reply back along reverse path
 - ATA can use LSR to cause packets to MH to be routed via FA co-locate ATA at CH, and FA at MH
 - ◆ MH sends to CH using LSR, ATA/CH reverses the path

Various Mobile-IP Proposals

- ◆ Many Mobile-IP systems have been proposed (and some implemented)
 - Columbia's Mobile-IP
 - Sony's Virtual (VIP)
 - IBM's LSR Scheme
 - Stanford's MosquitoNet Scheme
 - IMHP (Internet Mobile Host protocol)
 - IETF's Mobile-IP for IPv4
 - IETF's Mobile-IP for IPv6
 - etc.
- ◆ All are special cases of the canonical mobile-IP architecture
 - Make different choices of
 - ◆ FA location
 - ◆ ATA location
 - ◆ Choice of LUP address translation mechanism

Example: Columbia's Mobile IP

- ◆ Campus environment with a reserved subnet for MHs
 - MHs home address are from the reserved subnet
- ◆ Group of cooperating Mobile Support Routers (MSR)
 - MSRs advertise reachability to wireless subnet via beacons
 - MHs connect to campus backbone through MSRs
 - MSRs forward traffic to/from MHs
- ◆ On moving, MH registers with the new MSR
 - New location is provided to the previous MSR
- ◆ CH sends packet to MSR closest to CH
 - This MSR either delivers the packet or, forwards it to the right MSR after encapsulation
 - Right MSR is located by a multicast WHO_HAS query to other MSRs
- ◆ Wide area operation uses a pop-up mode
 - A temporary address is used by MH as a forwarding address
 - MH does its own encapsulation/decapsulation

Columbia Proposal

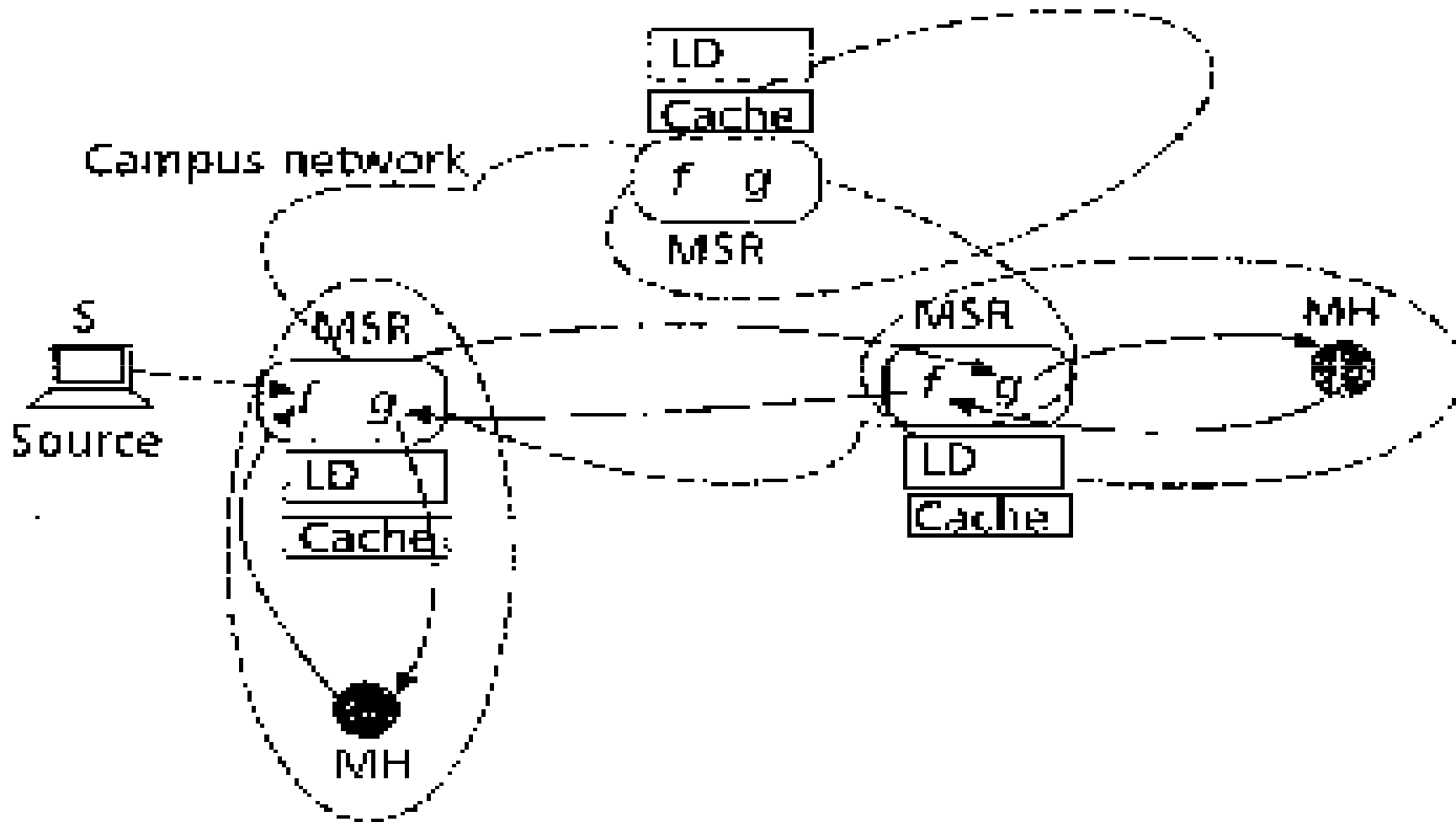

Columbia's Mobile-IP Mapped to Canonical Architecture

- ◆ MSR performs both encapsulation & decapsulation
 - Both f and g are collocated at MSR
 - MSR acts as FA for MHs in its coverage area
 - MSR acts as ATA for packets addressed to other MHs
- ◆ LD is distributed realization of the owner-maintains scheme
 - Each MSR maintains a table of MHs in its coverage
 - MSRs are a distributed realization of home router
 - Tables of MHs in MSRs together constitute an owner-maintained LD
- ◆ Caching policy for LD entries is “need-to-know”
 - MSR sends WHO_HAS query if it does not know MH's location
- ◆ LUP is lazy-update
 - When MH moves, only primary and previous copy of LD entry is updated
 - Cached entries are assumed correct by default
 - Stale cache entry causes packet delivery failure, triggering WHO_HAS
- ◆ 100% backward compatible – no existing internet entities are affected

Performance Characteristics of Columbia Mobile-IP



- ◆ Control
 - LD cache at ATA is updated when packet routing is needed
 - Limits control traffic
 - But, slow “first” packet due to WHO_HAS query results in SYN packet being lost in TCP (start of transmission)
- ◆ Overhead of IP-in-IP
 - 20 bytes (4% on 500 byte packets)
- ◆ Routing
 - Requires routing to nearest MSR to be optimal
 - Not optimal for pop-up mode
- ◆ Implementation on 33 MHz 486 based MSRs
 - 1.4 ms for WHO_HAS
 - 45 microseconds for encapsulation (per packet overhead)

Route Optimization

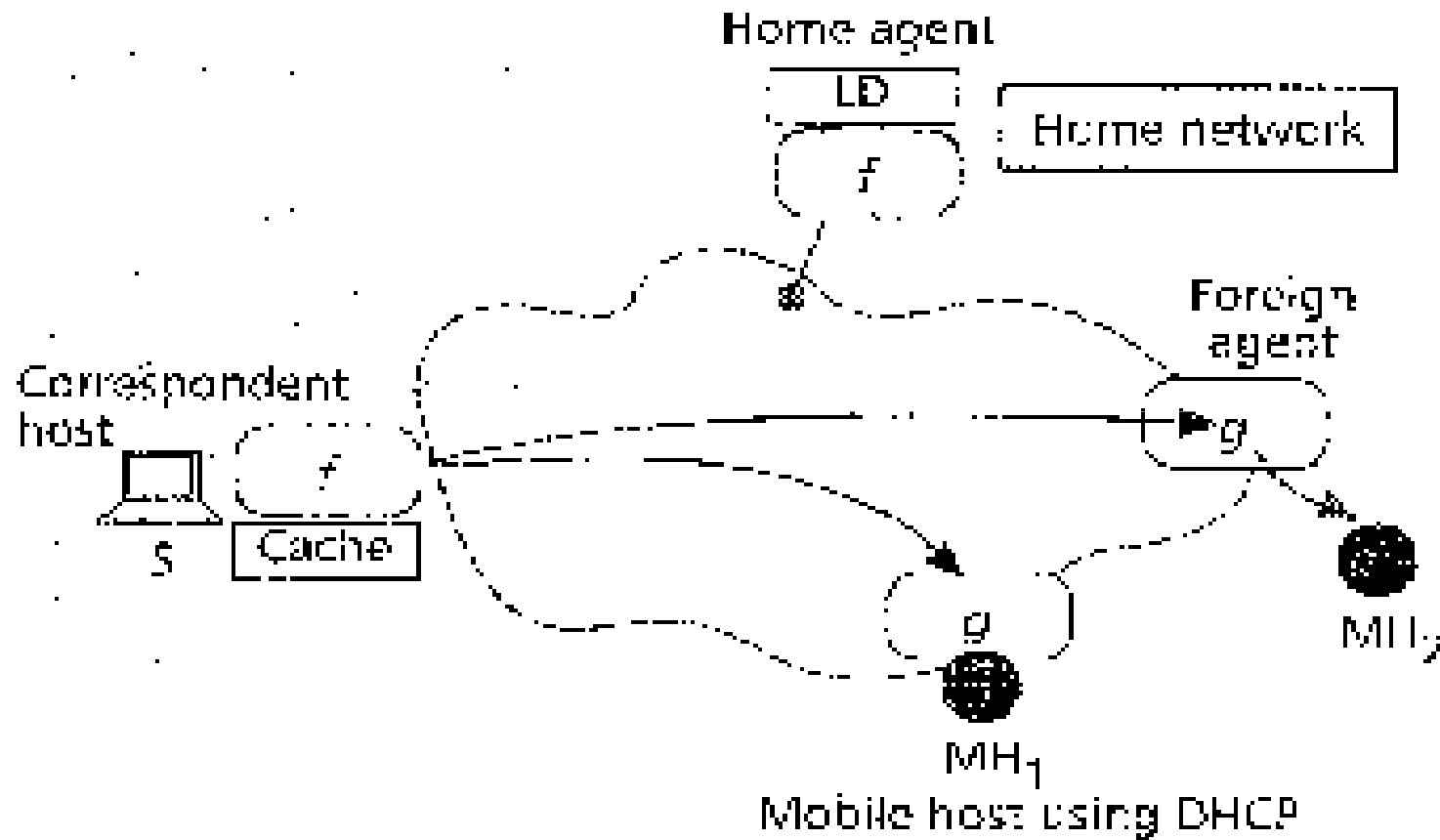

Route Optimizations



Figure 4. Behavior when CH is Close to MH



Figure 5. A Smart Correspondent Host.

Security Issues

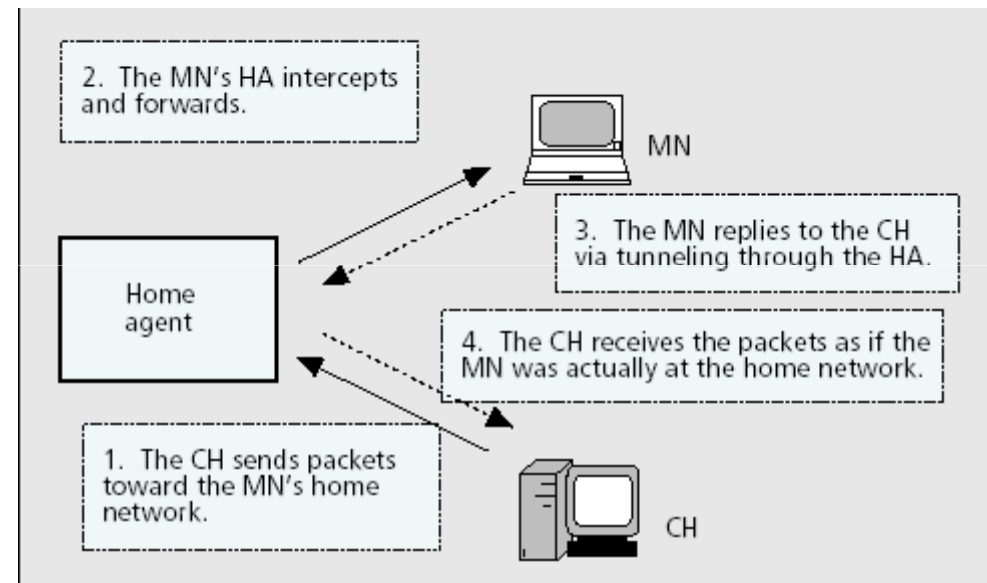
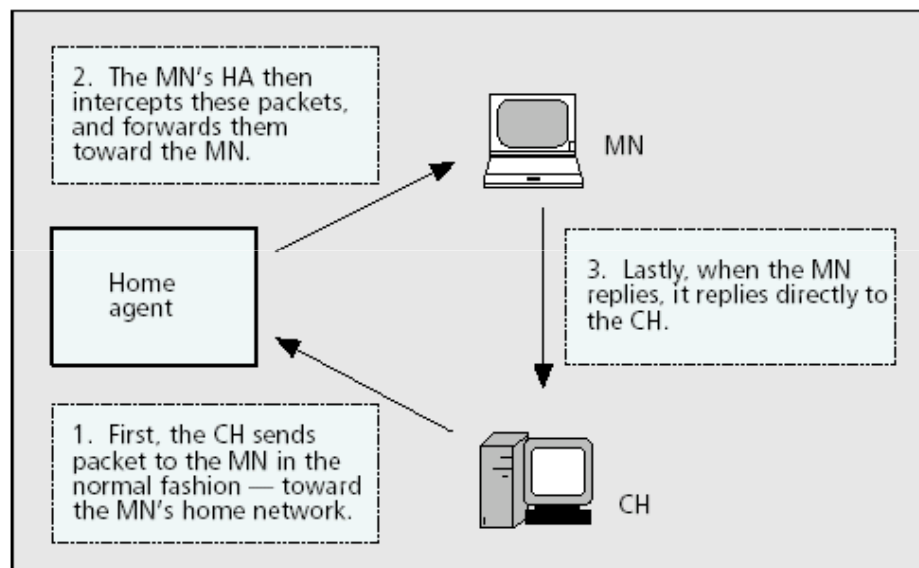

Figure 2. Problem with Source Address Filtering

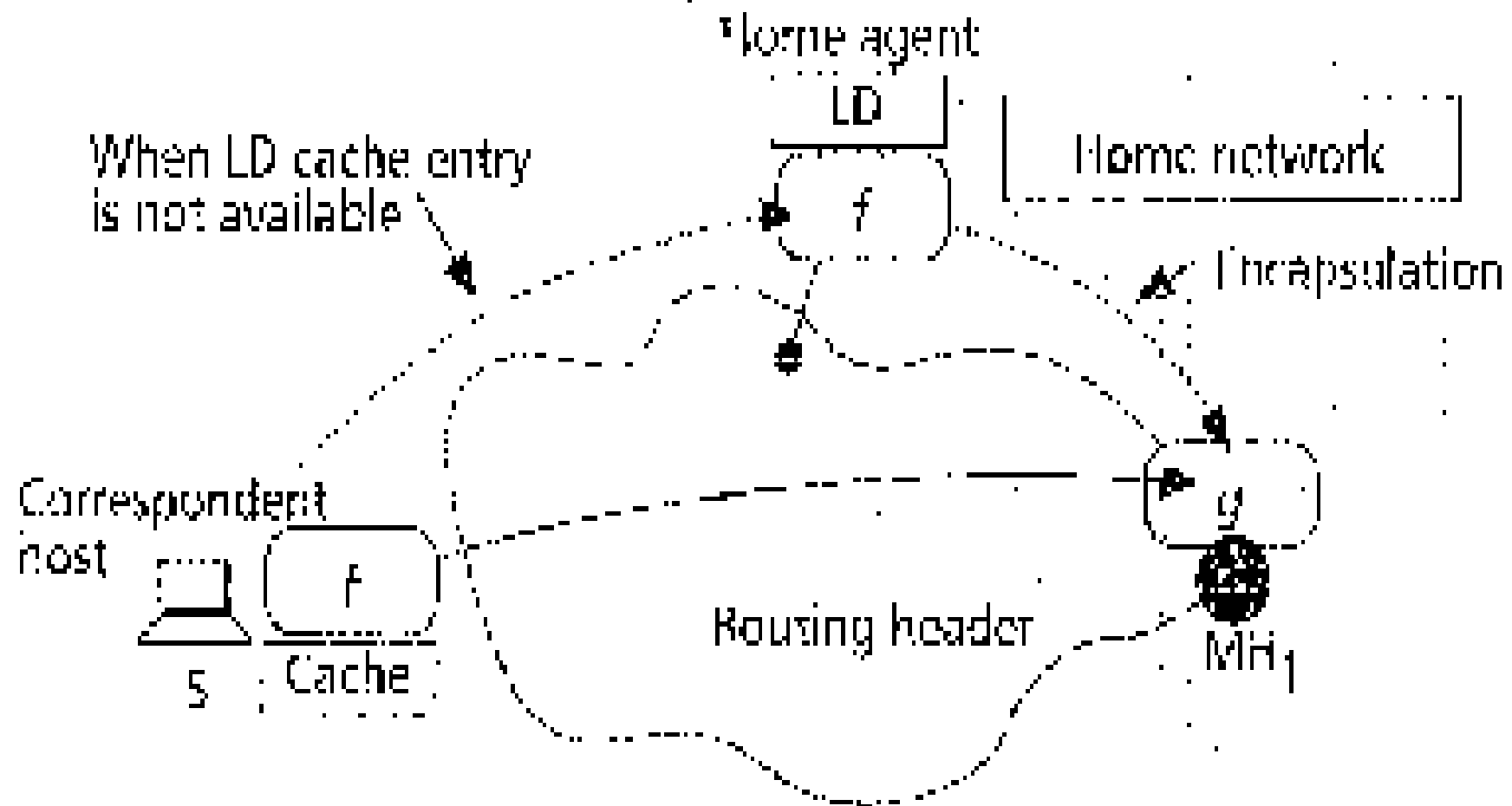

Figure 3. Bi-directional Tunneling

Tunneling



IPv6 Mobility Proposal



Evolutions of PCS



PCS Requirements

PCS network architecture

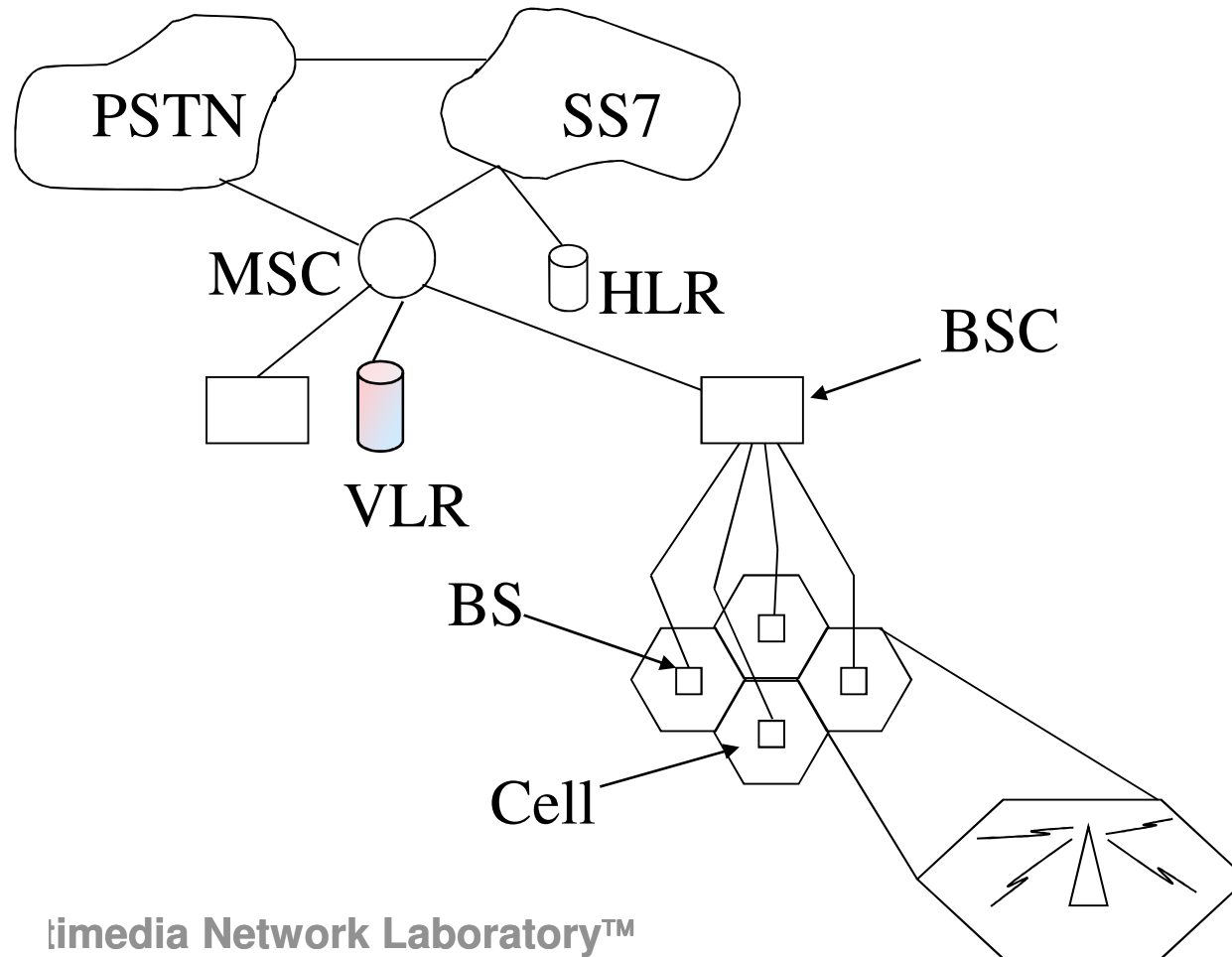

Location Update Procedure

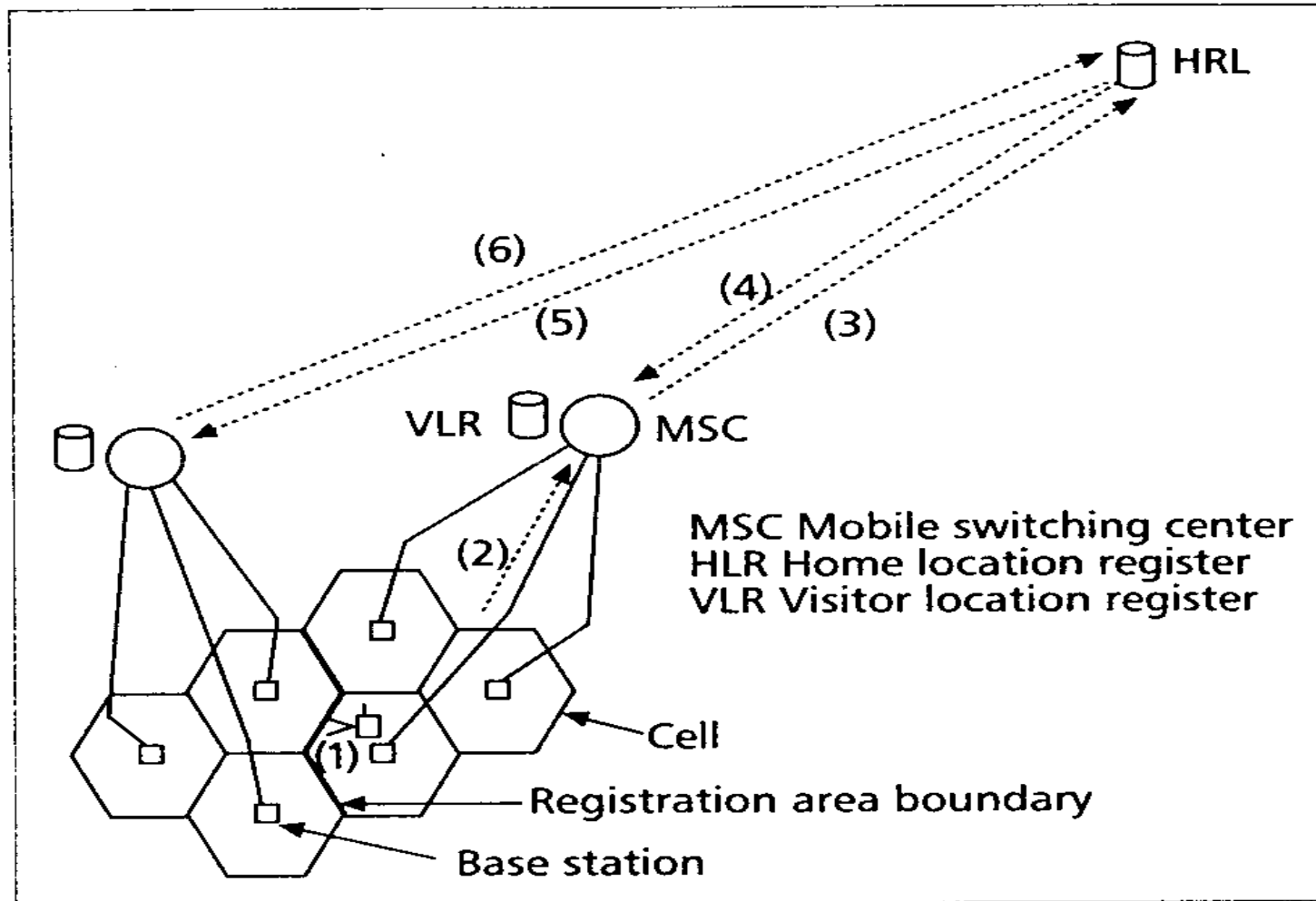

■ Figure 3. Location registration procedures.

GPRS

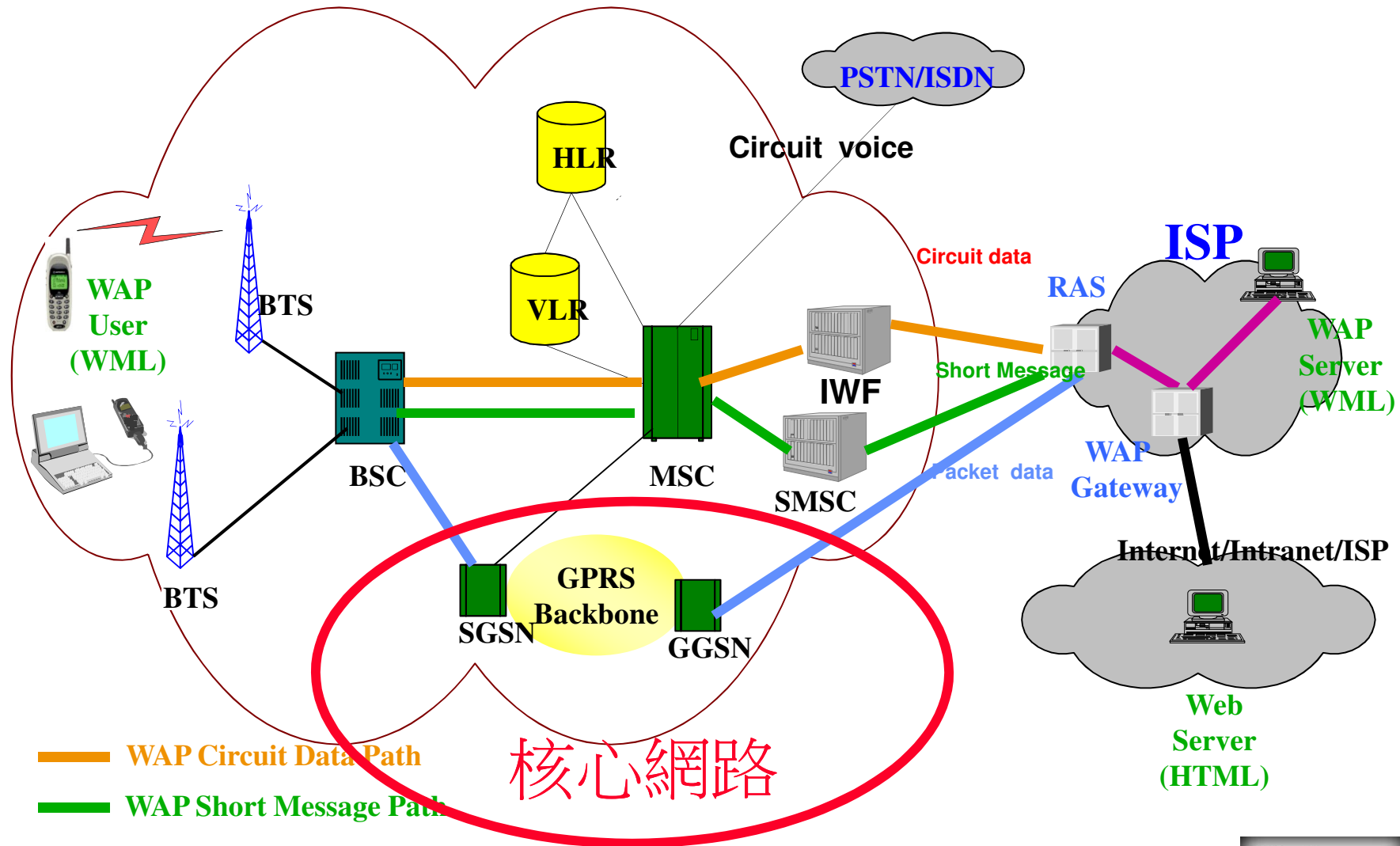

Data transfer MS-fixed

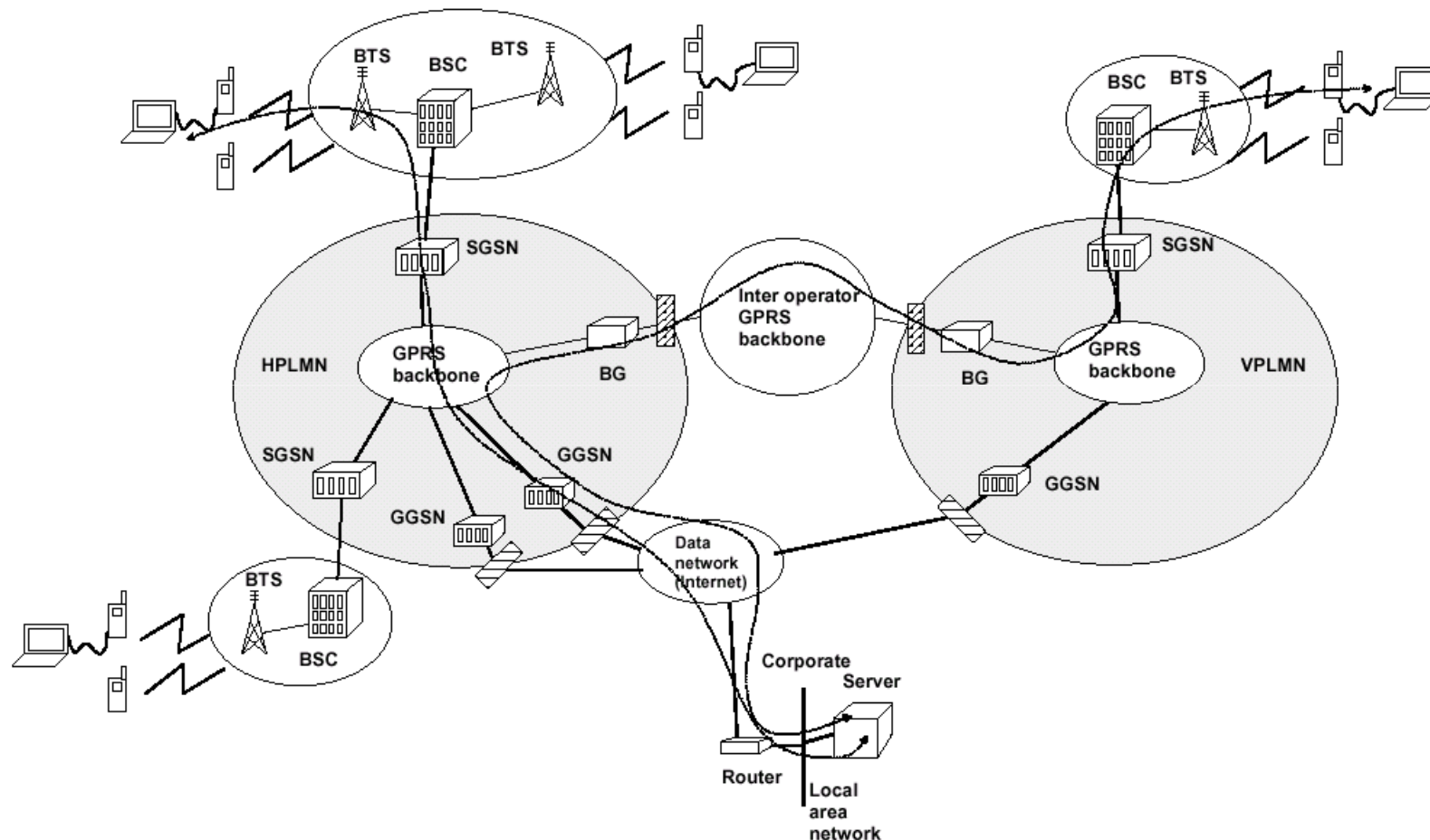

Data transfer MS-MS

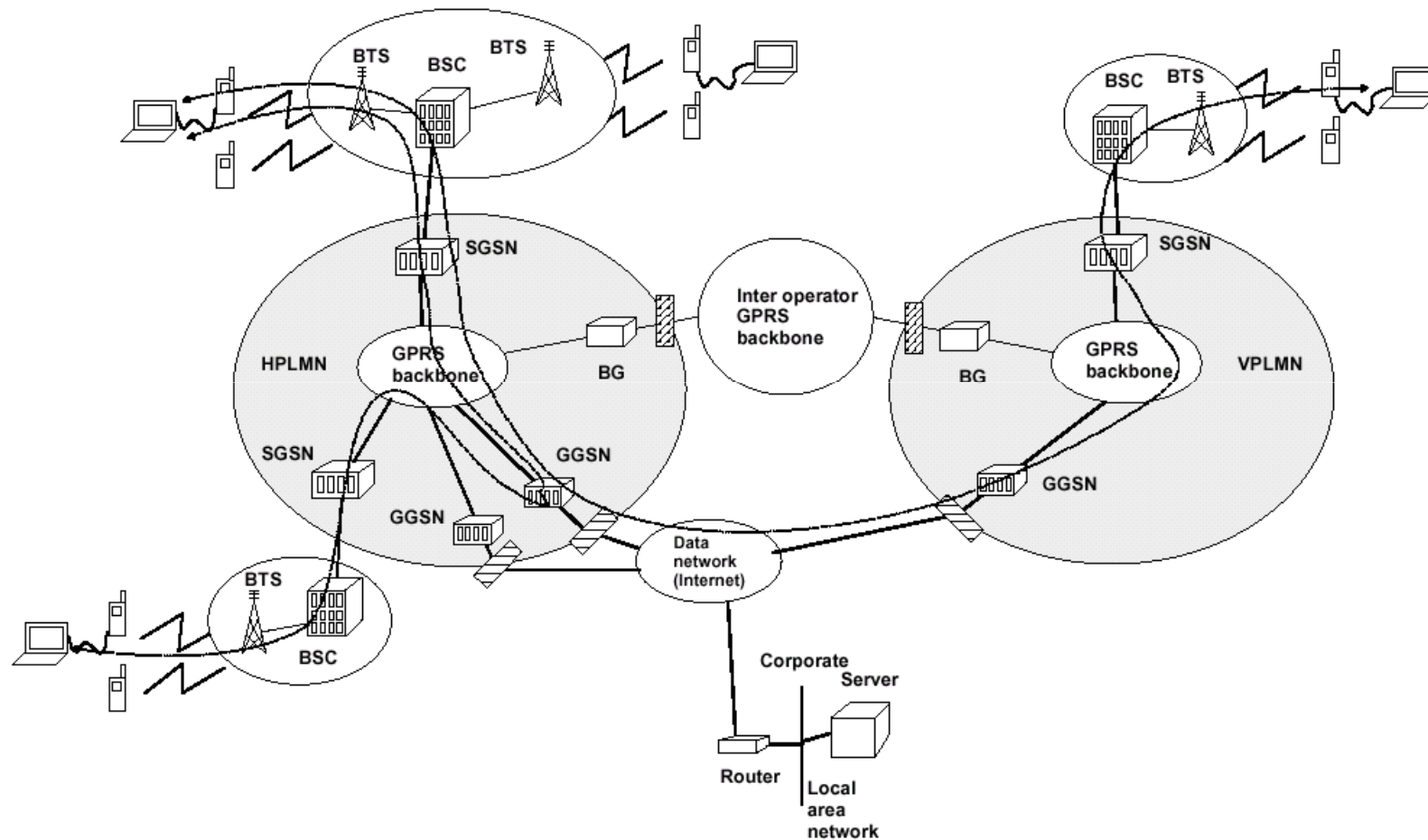

Coming Challenges for IP



Location Managements~ handoff, roaming

QoS Transport~ Backbone delivery

Mobility

- ◆ User mobility

- Micro
- Macro



- Handoff issue
- Location management
- Paging

- ◆ IP mobility support

- Mobile IP
- Cellular IP
- HAWAII
- Hierarchical Mobile IP

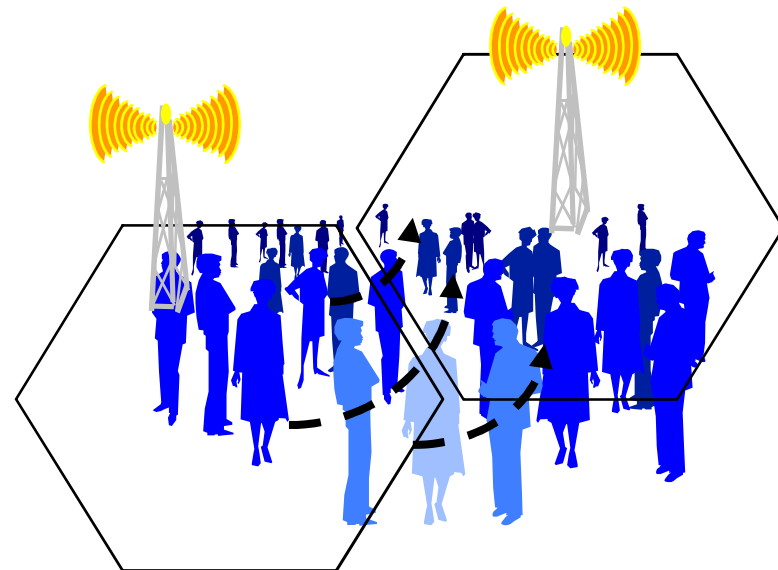

Nomadic wireless access

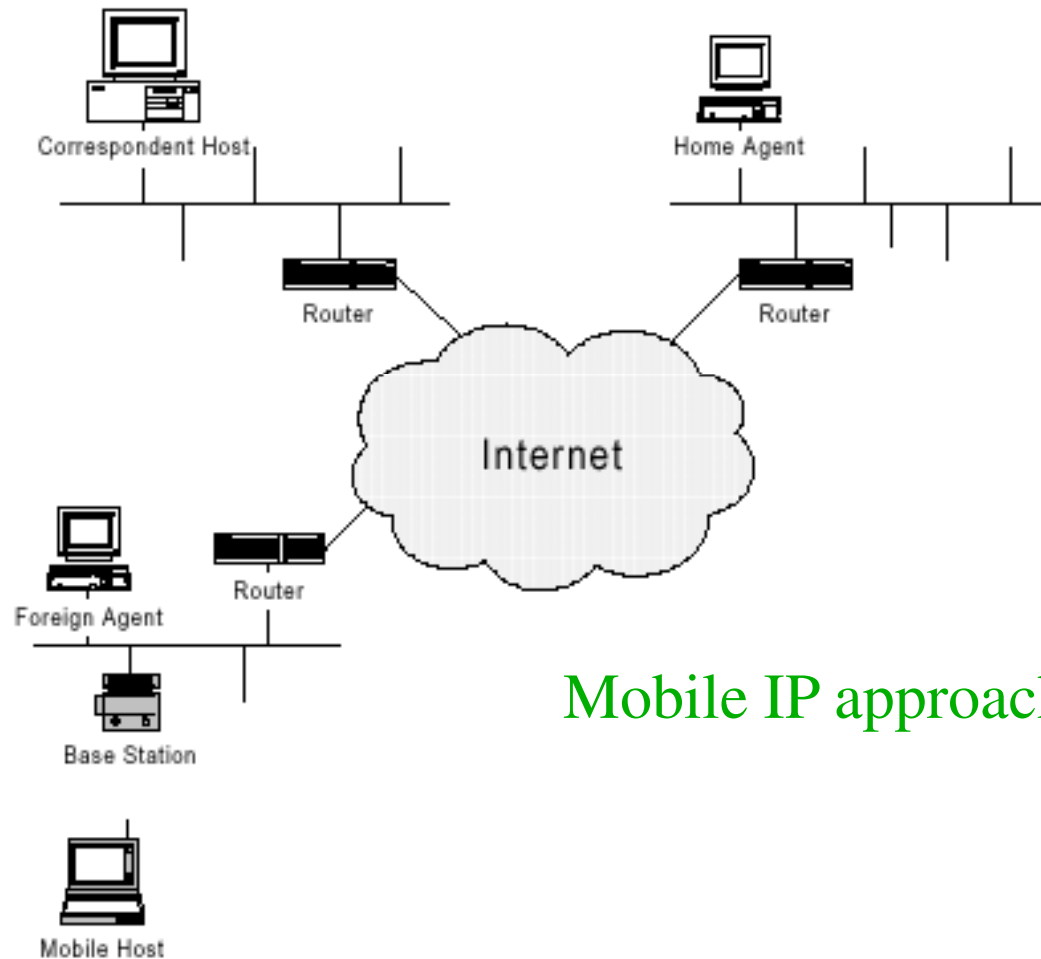

Mobile IP approach

Cellular IP

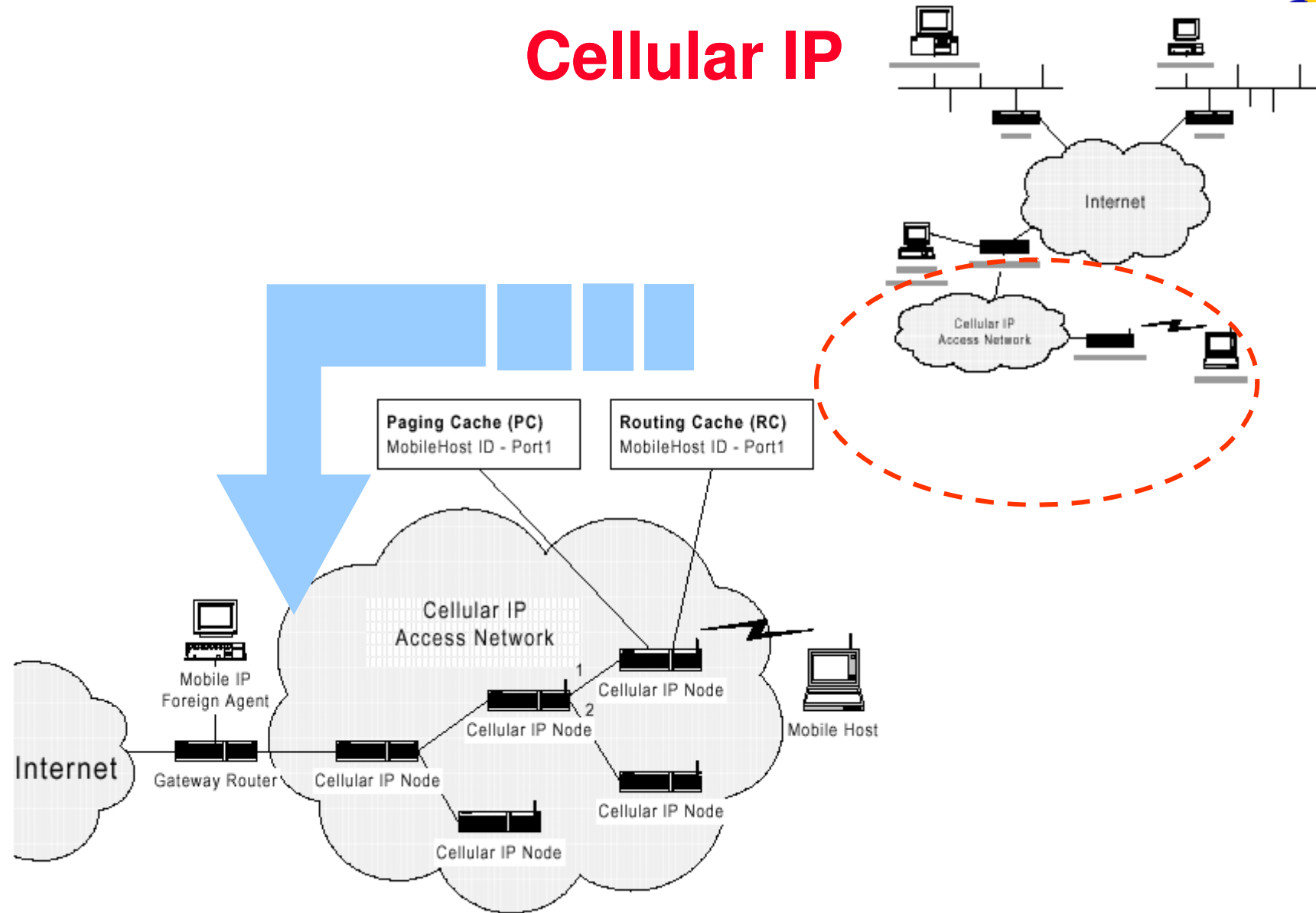

Hierarchical Mobility Management

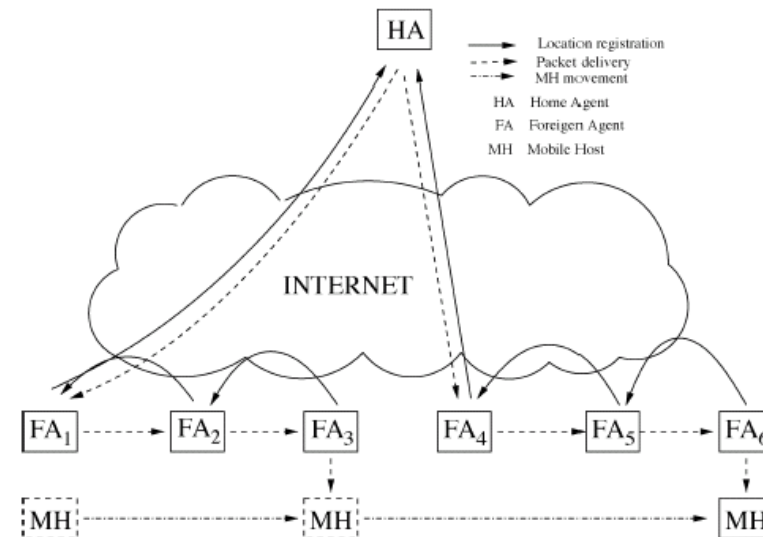
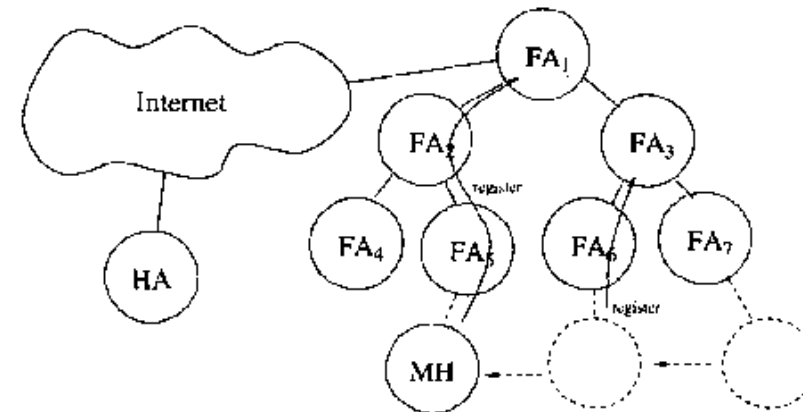
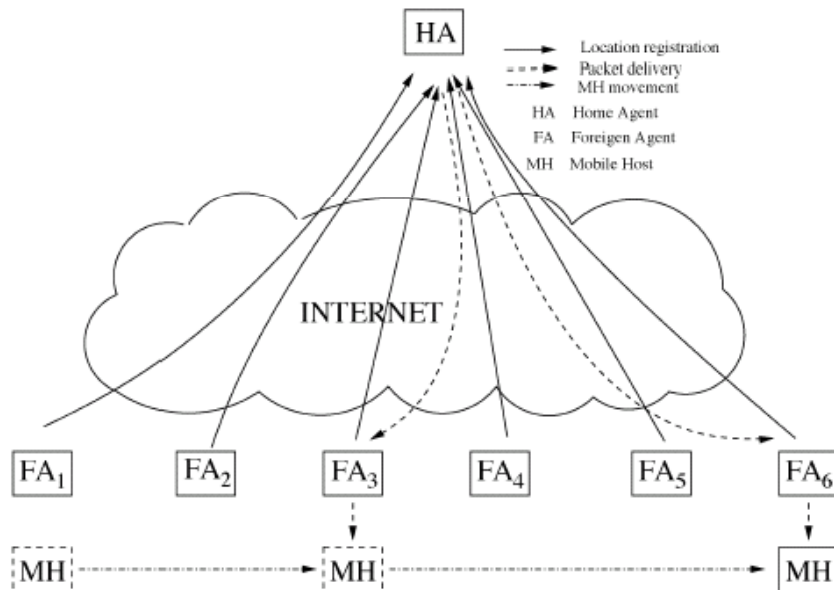

Mobility Management

- ◆ Mobility Classification
 - Roaming
 - Macro-mobility
 - ◆ Domain mobility
 - Micro-mobility
 - ◆ Subnet mobility
- ◆ Solutions
 - Network layer solution: Mobile IP
 - Application layer solution: SIP

Mobile IPv4: Registration Example

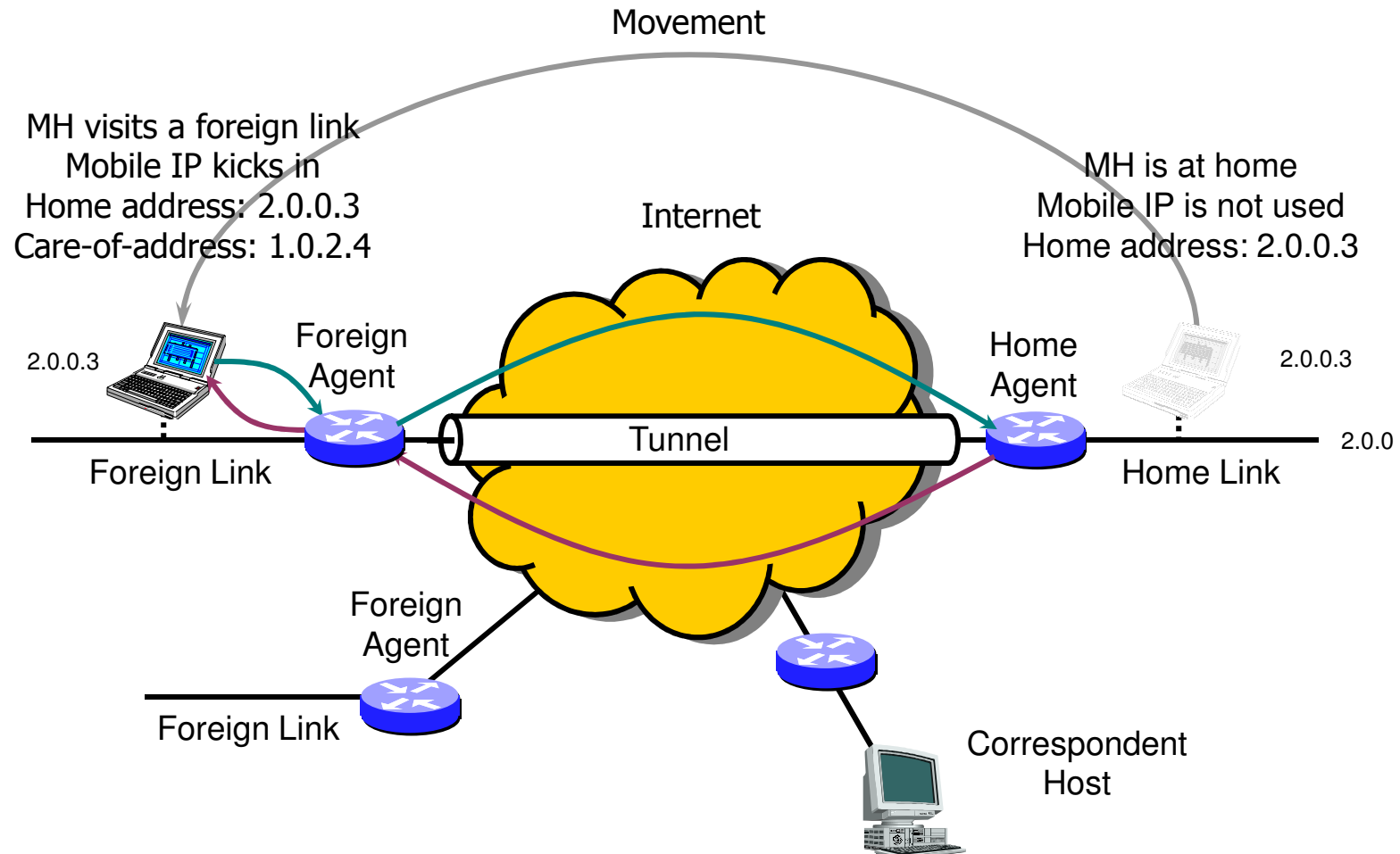

Mobile IPv4: CH-to-MH Routing Example

MH visits a foreign link
Mobile IP kicks in
Home address: 2.0.0.3
Care-of-address: 1.0.2.4

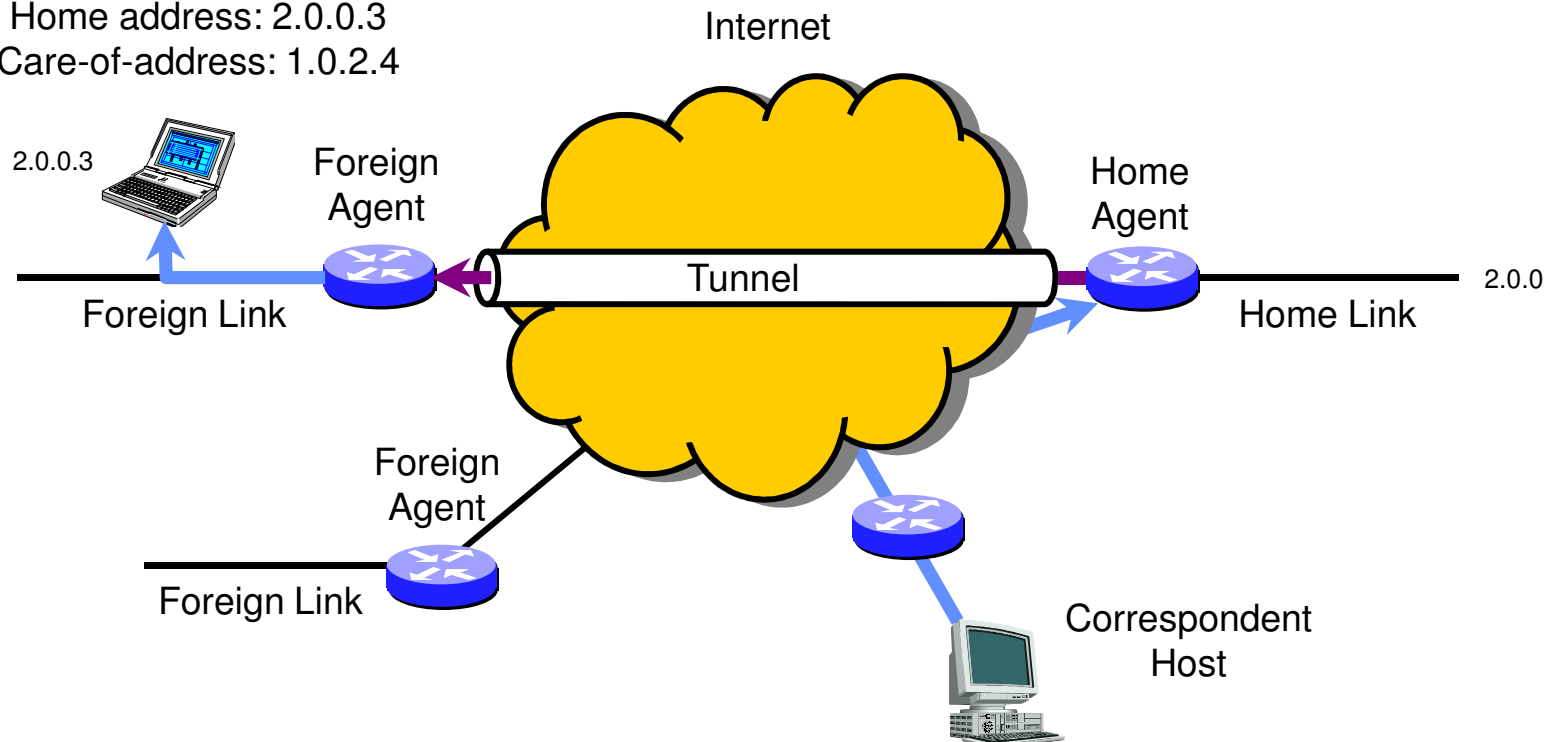

Mobile IPv4: MH-to-CH Routing Example

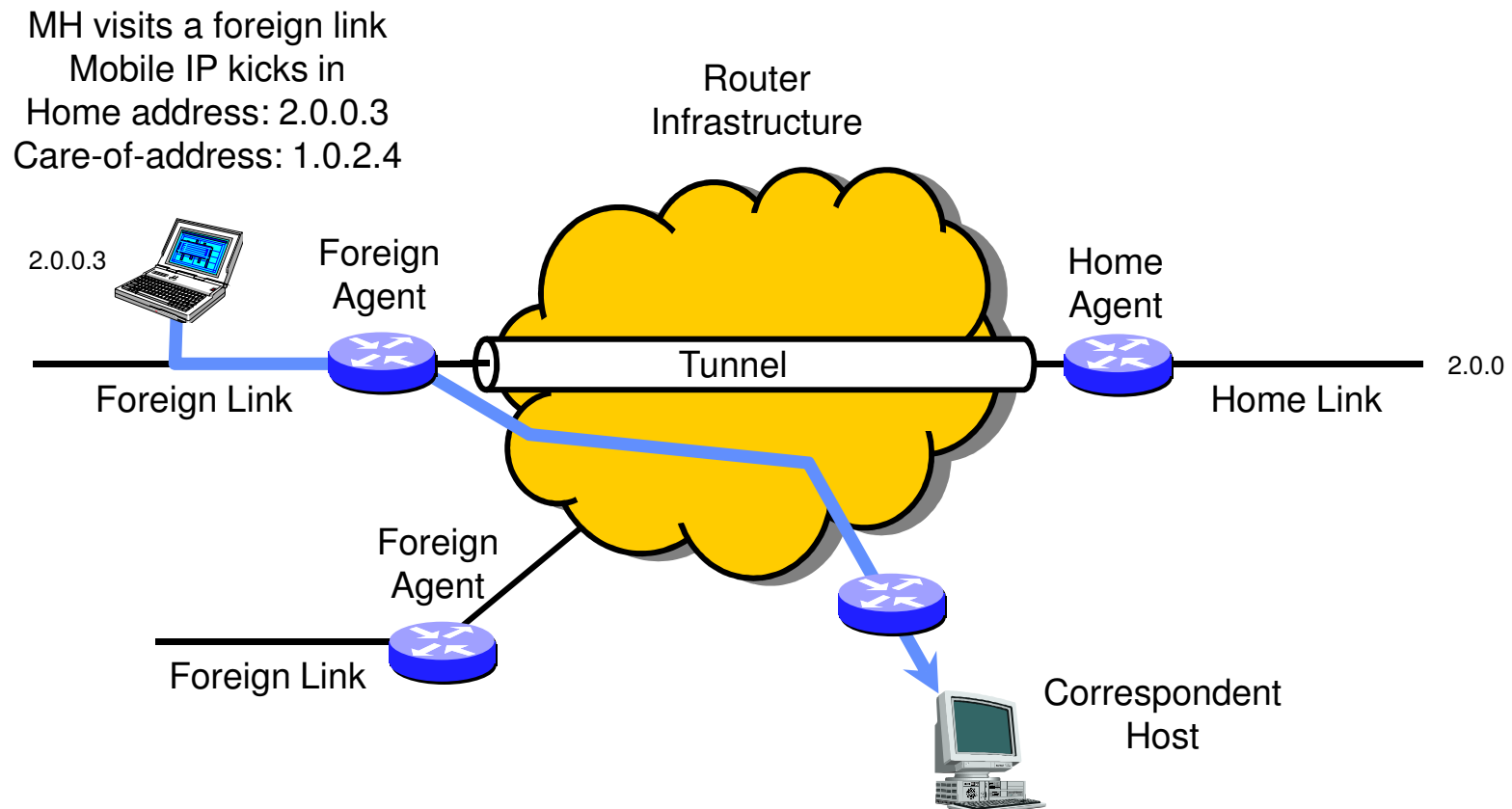

Mobile IPv4

- ◆ Triangle route problem
- ◆ Micro-mobility improvement
 - Cellular IP, Campbell in Column University.
 - Regional Registration, Perkins, Nokia Center.
 - ...

Mobile IPv6: Binding Update

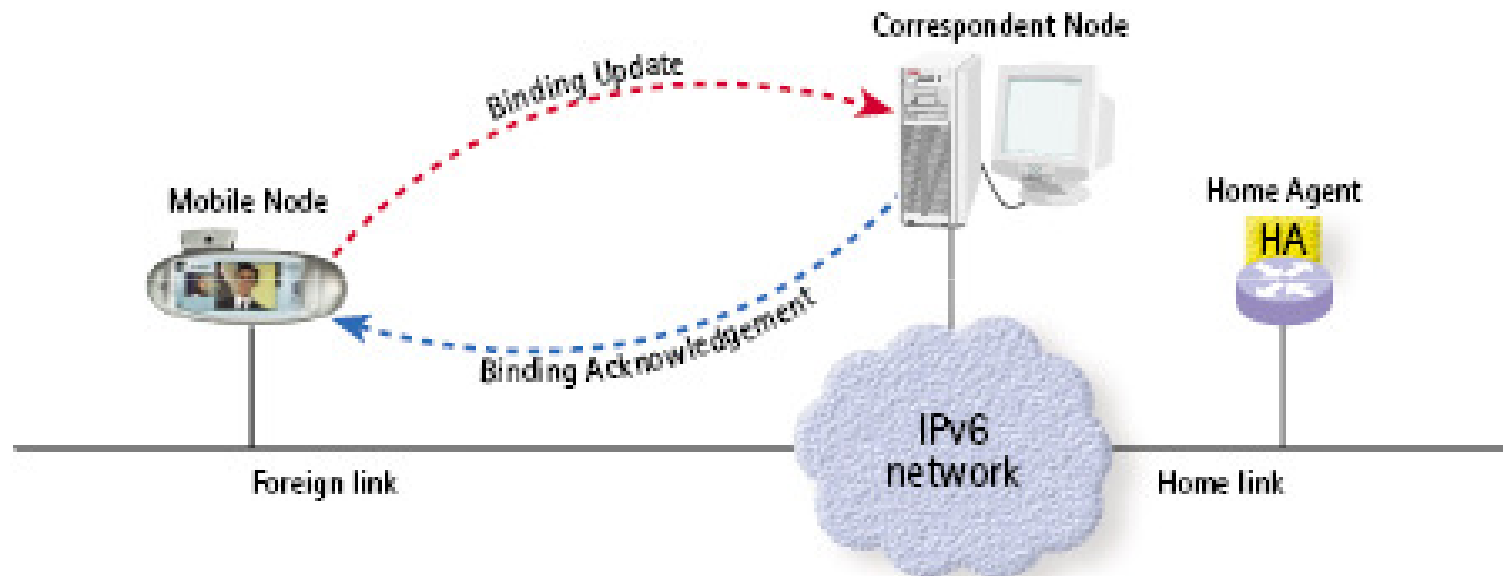

Application Layer Mobility Using SIP



- ◆ Terminal Mobility
- ◆ Session Mobility

Terminal Mobility

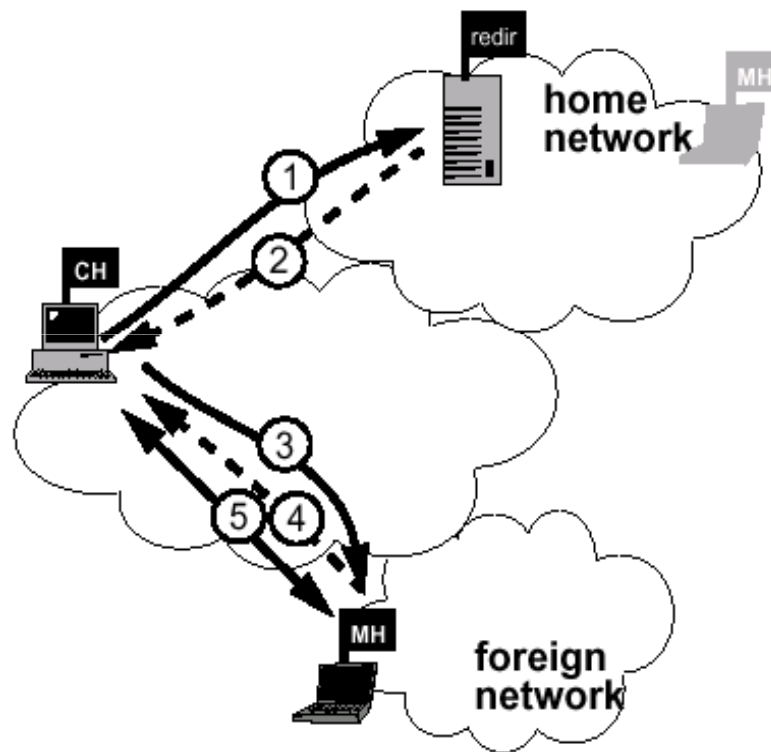

-  mobile host
-  correspondent host
-  SIP redirect server
- ① SIP INVITE
- ② SIP 302 moved temporarily
- ③ SIP INVITE
- ④ SIP OK
- ⑤ data

Terminal Mobility

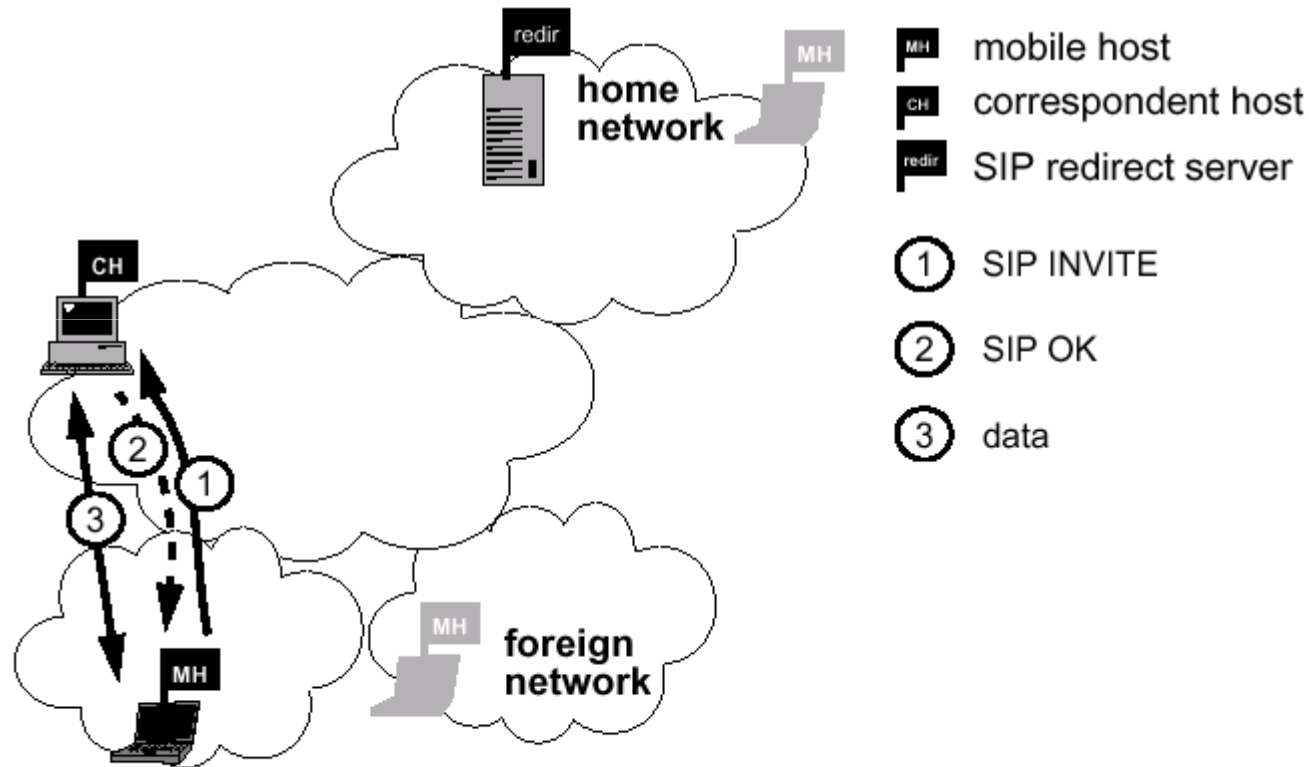

Session Mobility

- ◆ Allow a user to maintain a media session even while changing terminals.

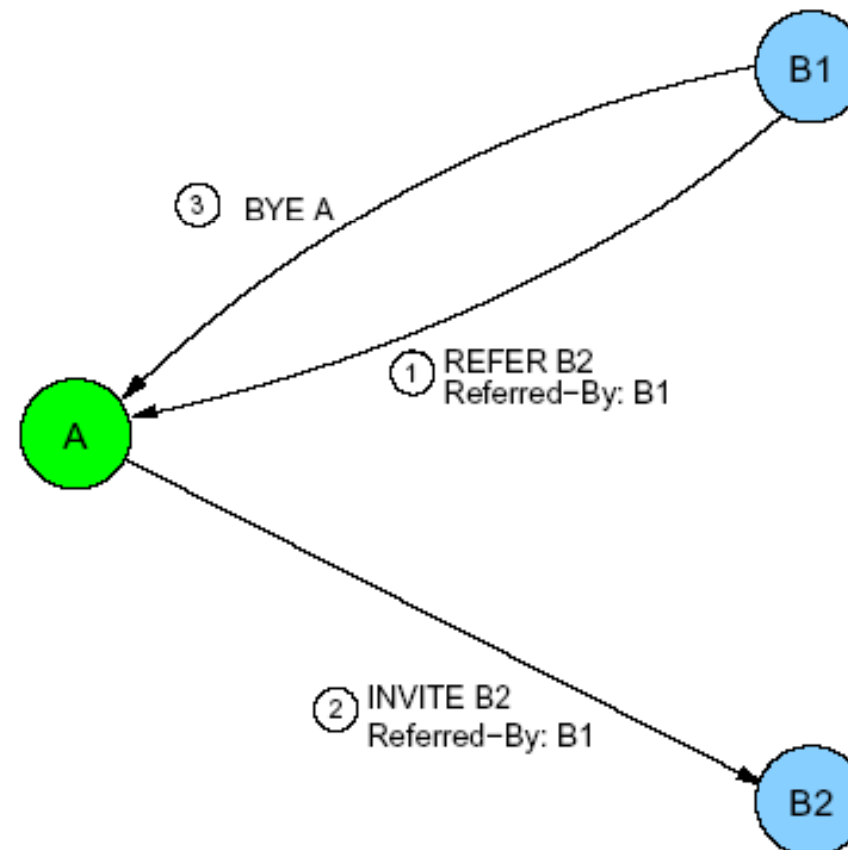

Mobile Network Architecture

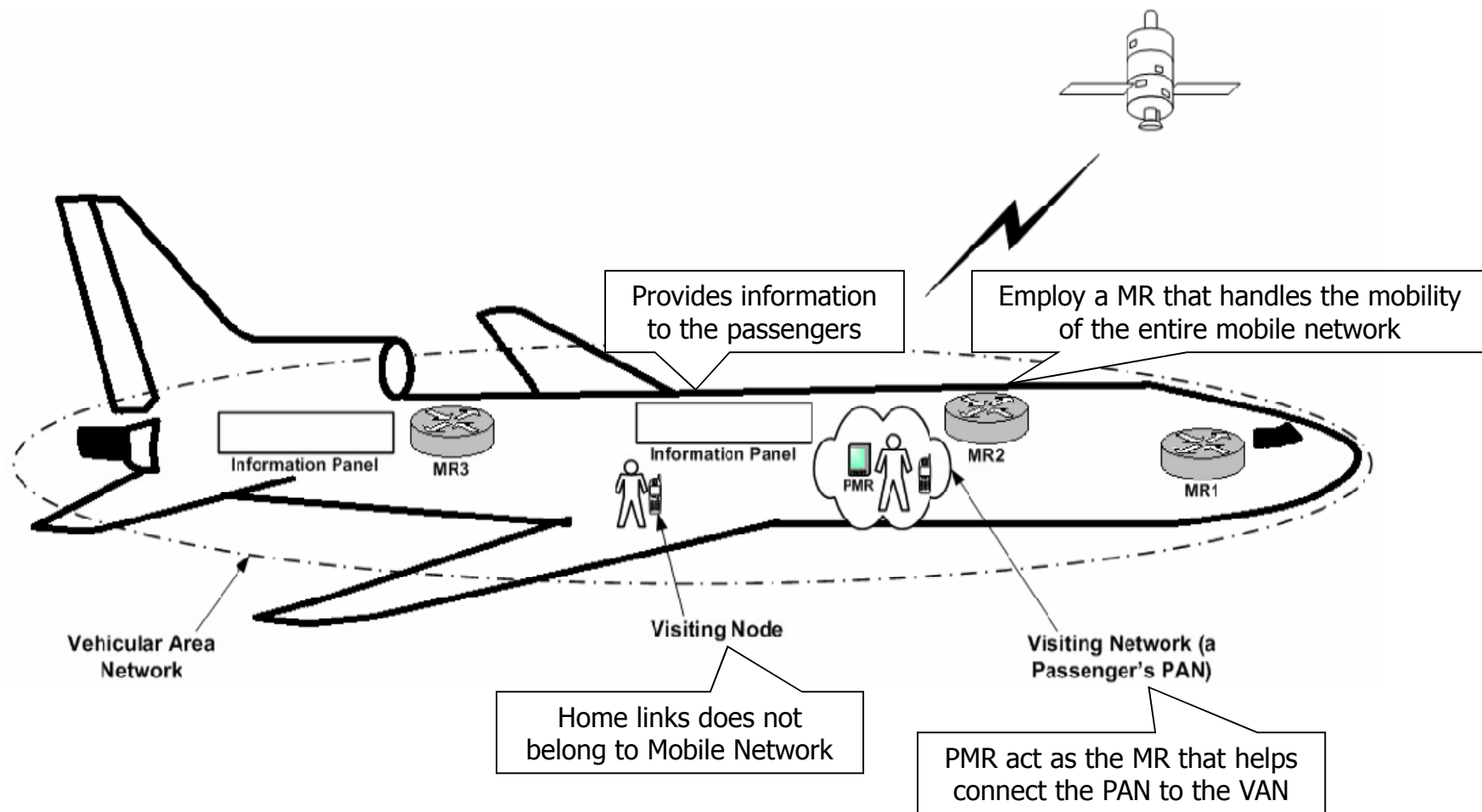

How the NEMO works

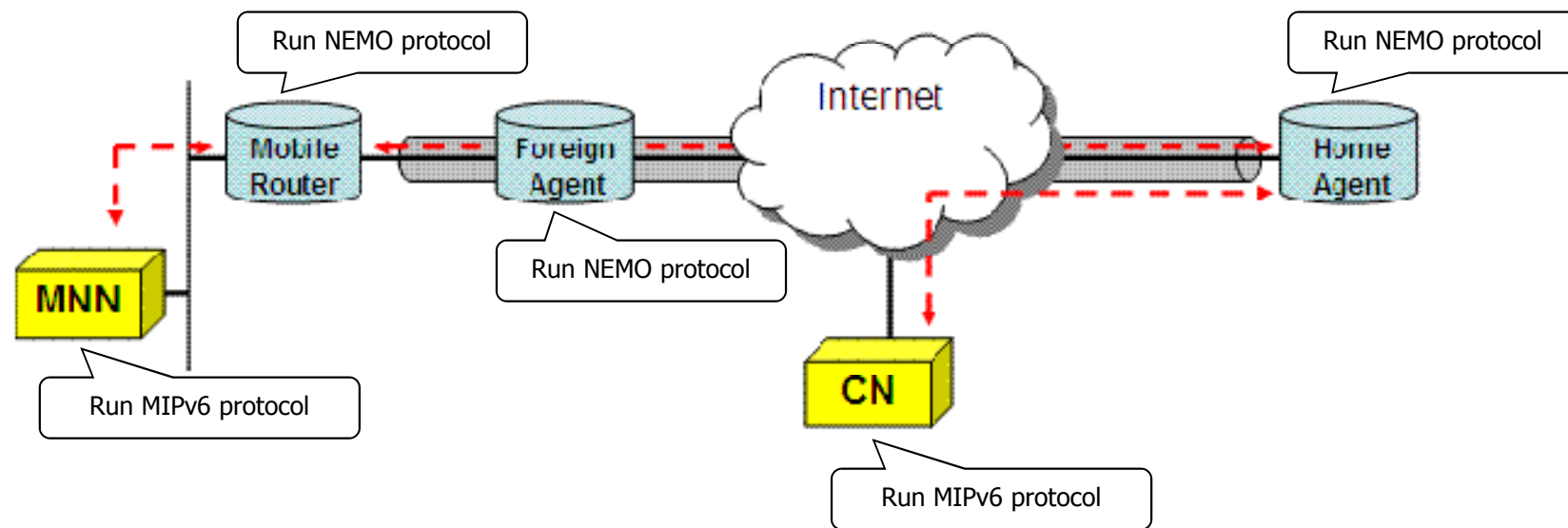

NEMO Binding update & Packet Delivery procedure

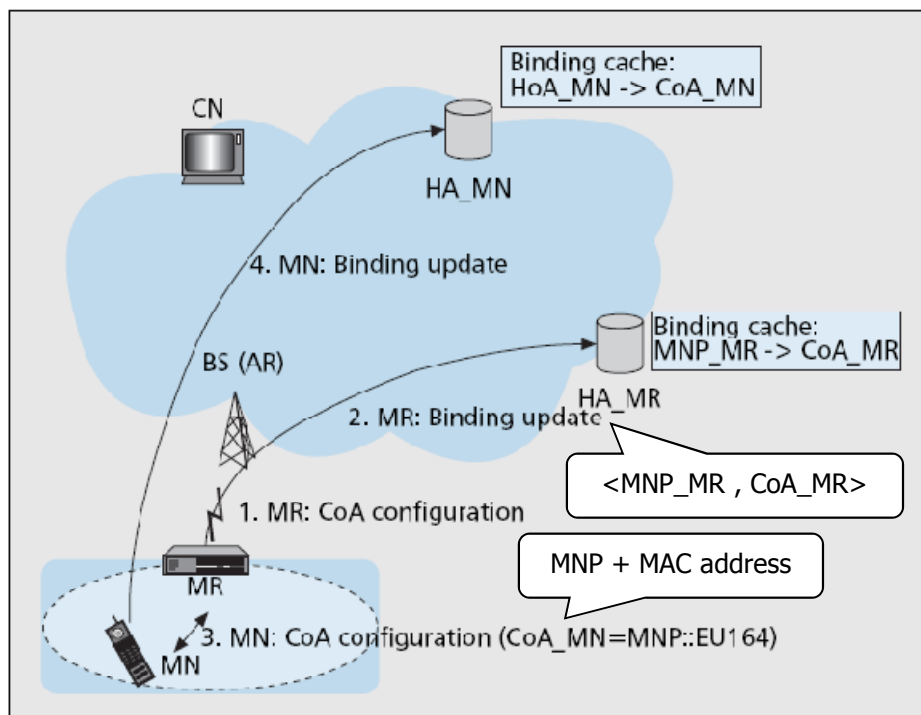

Binding update procedure of the NEMO basic support protocol.

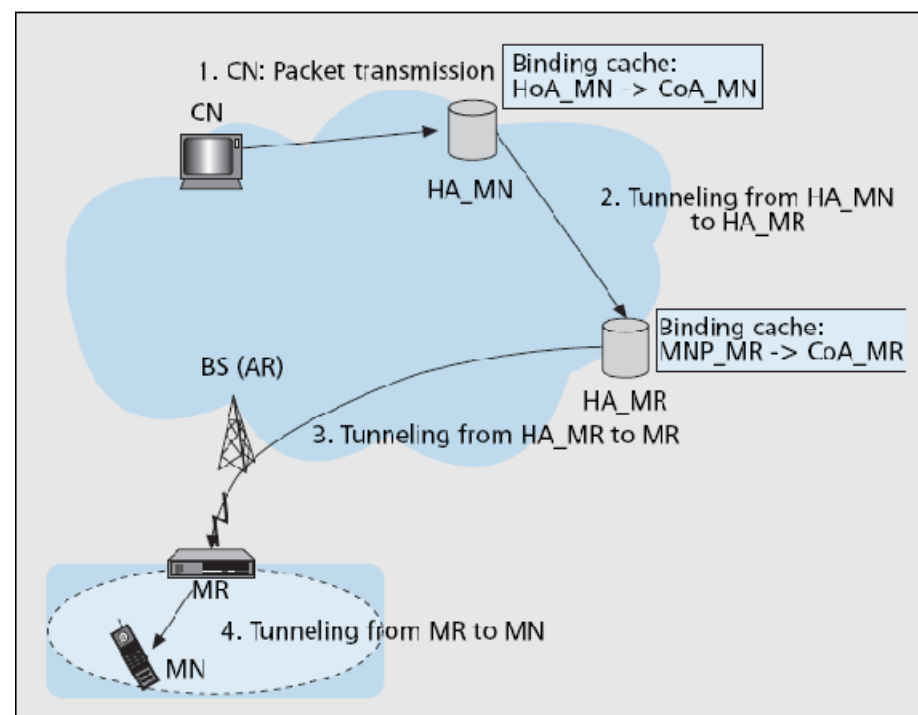

Packet delivery procedure of the NEMO basic support protocol.

SafeWeb

- ◆ A big proxy
- ◆ Reassembly HTML to hide user info.
- ◆ Using SSL between SafeWeb and Client

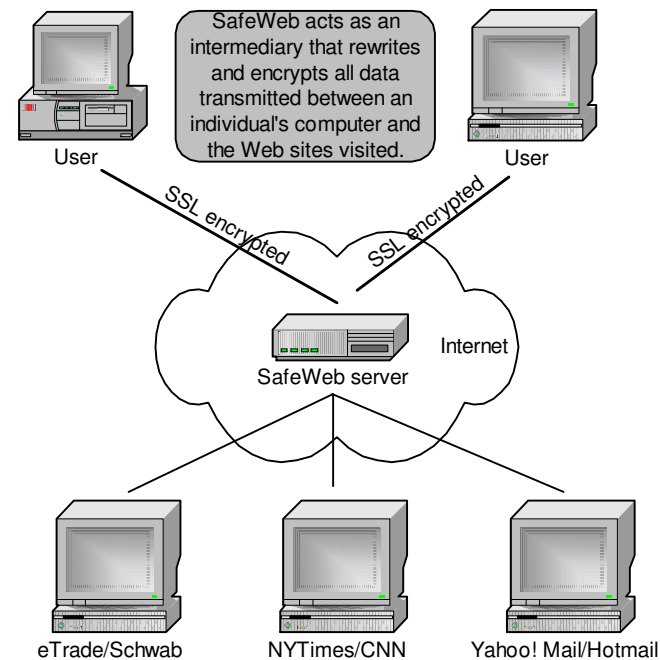
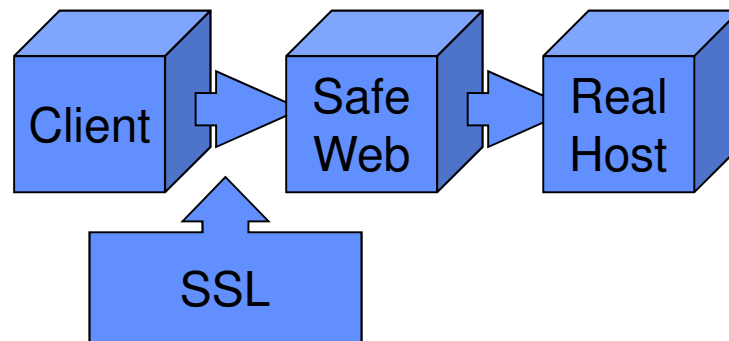

Screenshot of SafeWeb



TBoy

- ◆ Redirect the Request to SafeWeb
- ◆ SafeWeb will send response using TBoy IP.

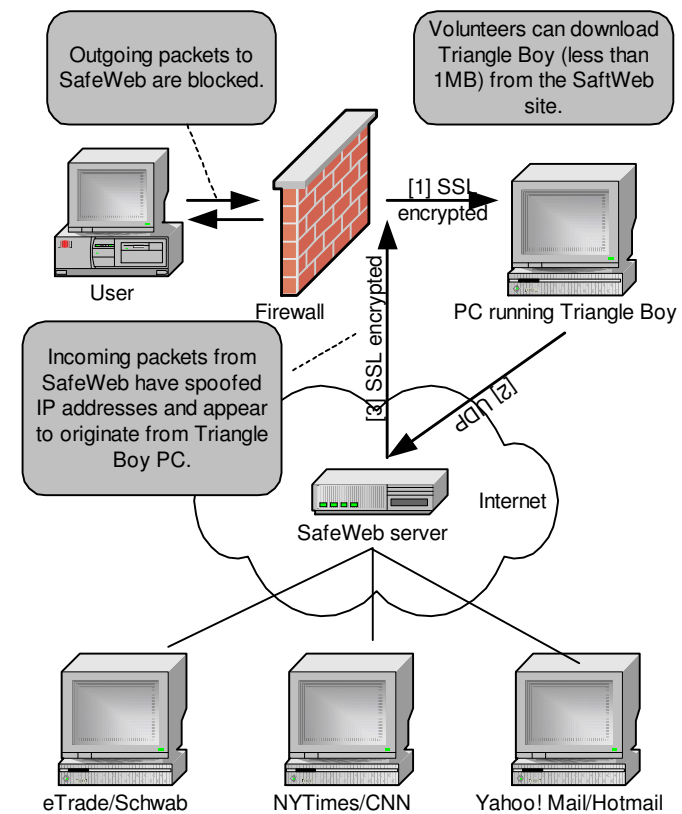
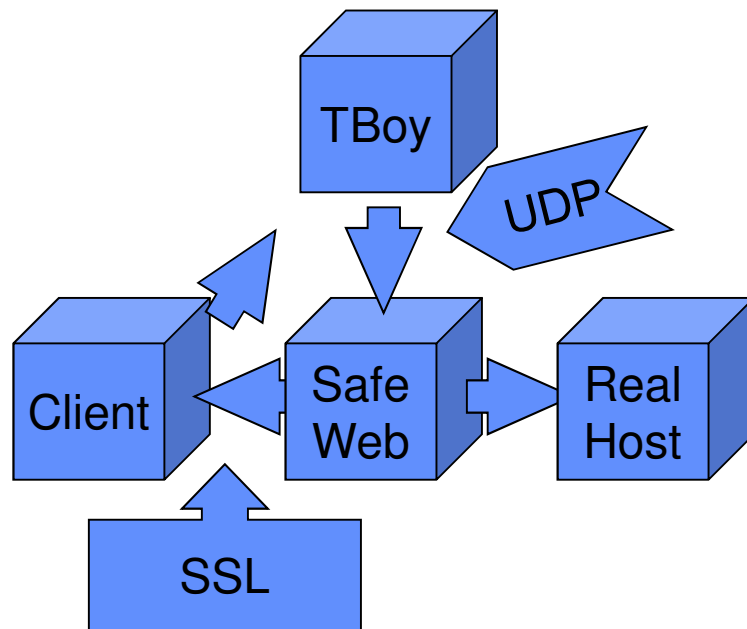

P-MIP

- ◆ A paging area consists of one or more networks

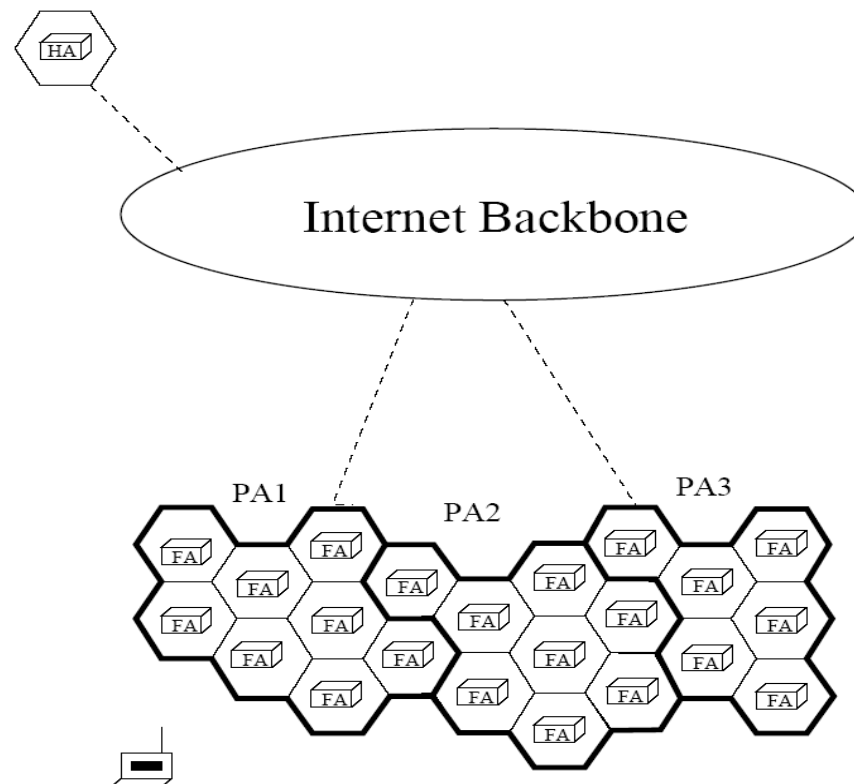

Hawaii (Handoff-aware Wireless Access Internet Infrastructure)

