

無線網路多媒體系統

Wireless Multimedia System

Lecture 5: Cellular Concepts
中央大學 吳曉光博士

We
provide
無線網路多媒體實驗室
Wireless
Wireless Network & Multimedia Laboratory
Solution

Mobility Support & Channel Reuse



Mobility Support~ Handover

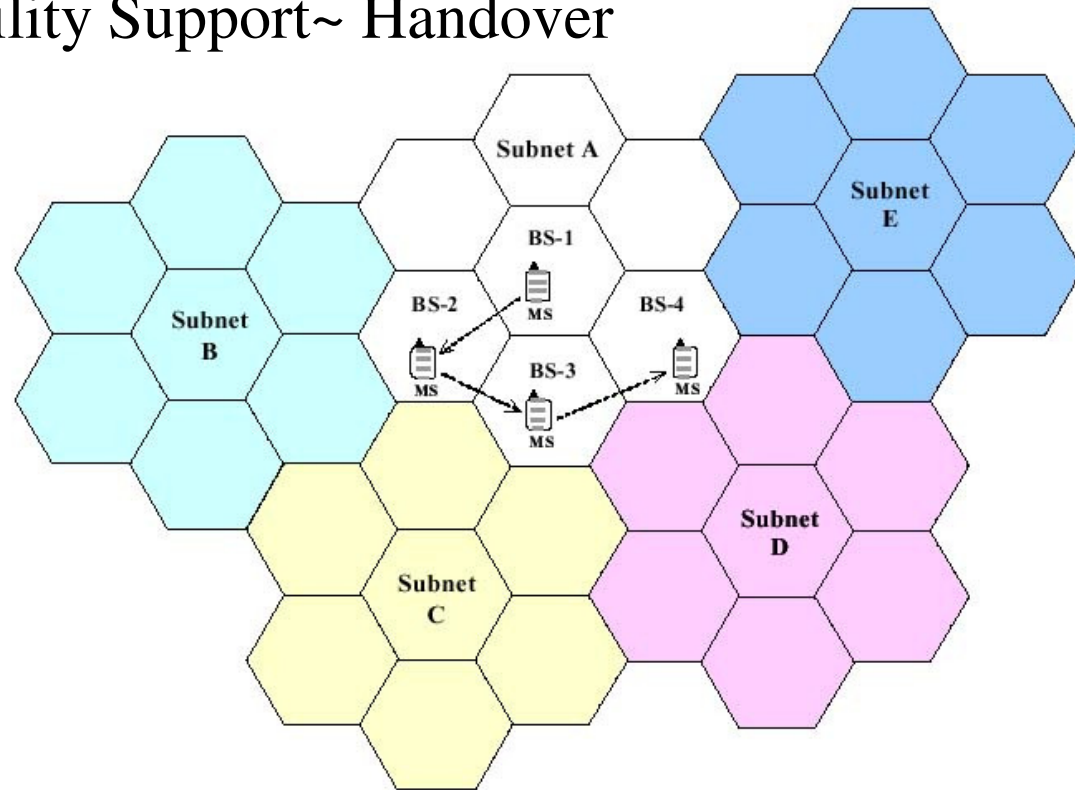

Channel Allocations: Reuse



NCU Life Information
中央大學生活資訊網

蔡能聰同學,歡迎使用成績查詢設定系統
請確實輸入欲接受"成績已到"短訊之手機電話號碼

[WAP 個人化設定](#)

[個人行事曆](#)

[WEB BBS](#)

[回首頁](#)

手機電話號碼

電子郵件帳號

- CE229
- CE401
- CE641
- IM644 海峽兩岸管理專題
- PE165 華捷標準舞
- CR001 操行



ChungLi Case Study

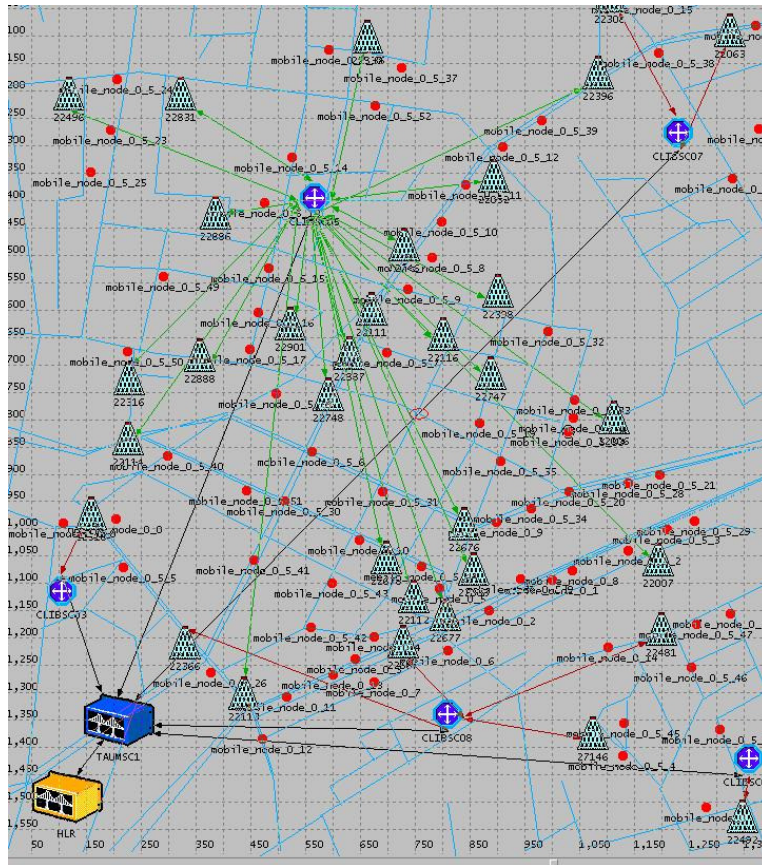

Moving Behavior

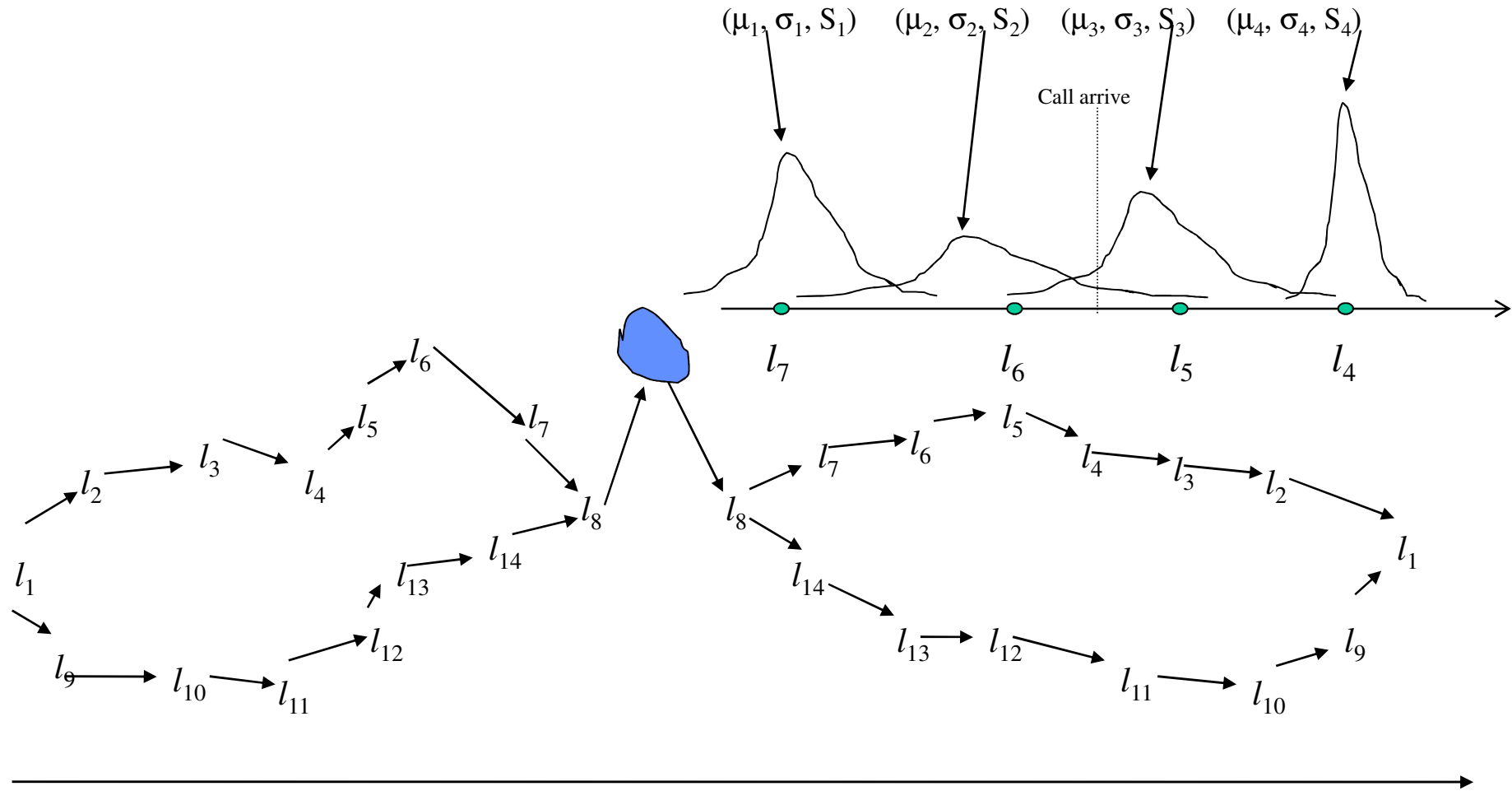

Mobile Broadband Infrastructure Diagram

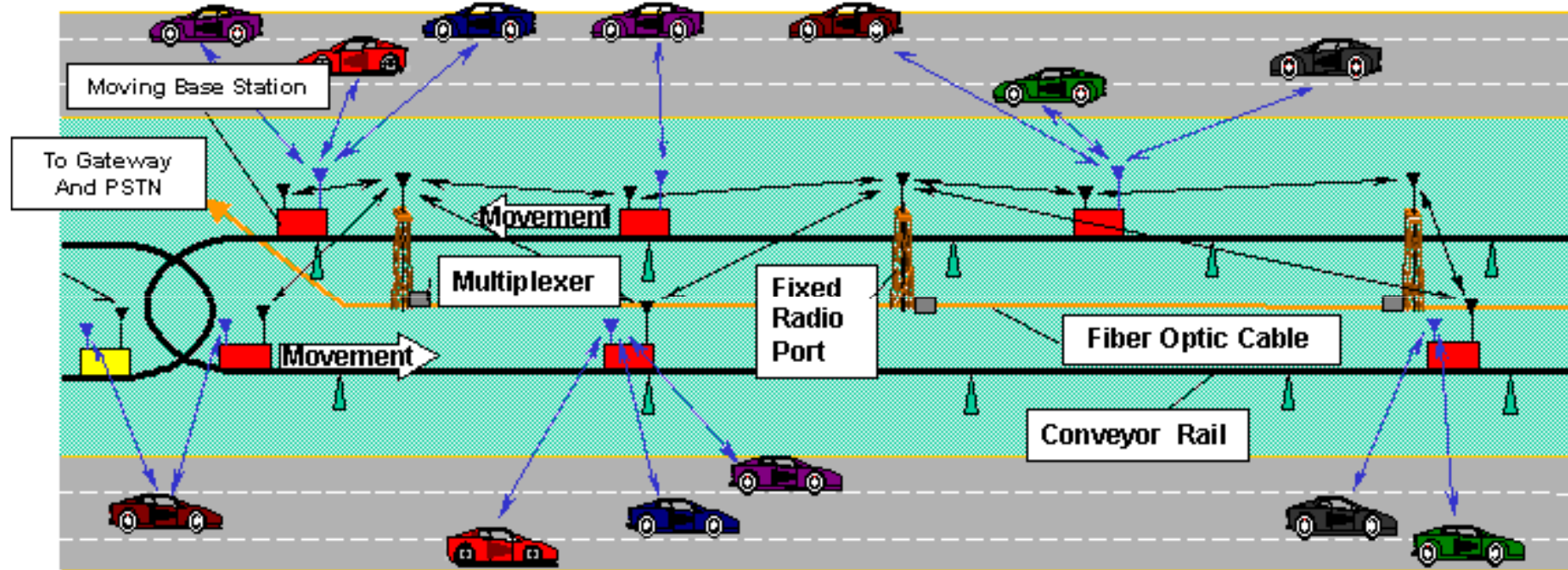

- 
20 Mbit/sec Channel using 5GHz CDMA Spectrum at 60 GHz
 Low Power from Mobile Unit to Moving Base Station
 High Power from Moving Base Station to Mobile Unit

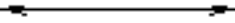
- 
5 GHz CDMA Channel at 60 GHz
 Low Power from Fixed Radio Port to Moving Base Station
 High Power from Moving Base Station to Fixed Radio Port

Channel Assignment in Cellular System

- ◆ Fundamental Problem:
- ◆ Fixed Channel Assignment
- ◆ Dynamic Channel Assignment
- ◆ Hybrid Schemes
- ◆ Whole Channel Usage (CDMA)
- ◆ Reduce the Cell Size

Hand-off in Cellular Networks

- ◆ Transfer of mobile to a new channel when it crosses cell boundary
- ◆ Handoff delay
- ◆ Prioritizing handoffs to reduce probability of dropped calls
- ◆ Handoff Strategies
- ◆ Network Controlled handoff (NCHO)
- ◆ Mobile assisted handoff (MAHO)
- ◆ Mobile controlled handoff (MCHO)

Agenda

- ◆ Cellular Concepts
- ◆ Channel Assignments
- ◆ Handover
- ◆ Next Lecture: 3G WCDMA design



Reading

- ◆ [Katzela96]Katzela, and M. Nahgshineh, "Channel assignment schemes for cellular mobile telecommunication systems: a comprehensive survey," IEEE Personal Communications, June 1996
- ◆ [Pollinin96], G.P. Pollini, "Trends in handover design," IEEE Communications Magazine, March 1996.

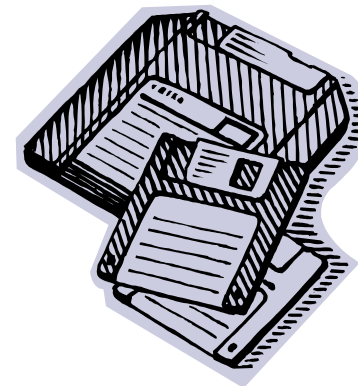

Channel Allocation

- ◆ A given Channel Spectrum (or bandwidth) can be divided into a set of disjoint or non-interfering radio channel
 - Frequency Division
 - ◆ frequency band
 - Time Division
 - ◆ time slot
 - Code Division
 - ◆ modulation code

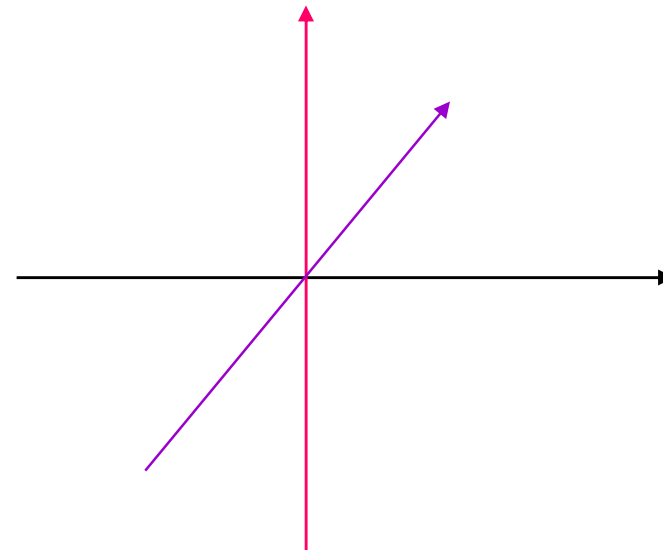

Cellular System Concept

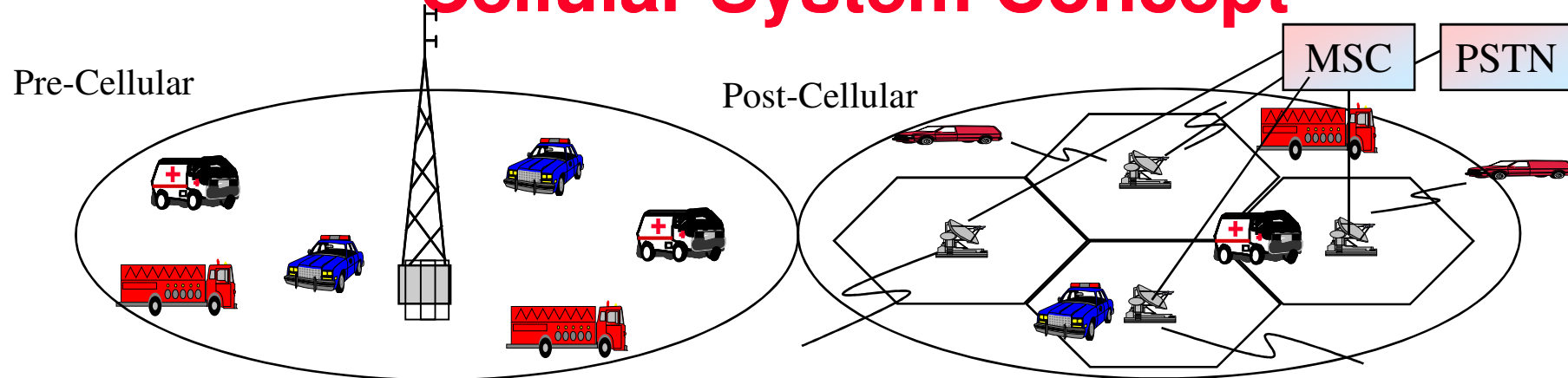

- ◆ Replace single high power transmitter covering the entire service area with low power
 - Mobiles in sufficiently distant base-stations may be assigned identical channel (frequency, time slot, & code)
 - System capacity may be increased without adding more spectrum
- ◆ Major conceptual breakthrough in spectra congestion & user capacity
 - Required relatively minor technological changes frequency reuse & co-channel interference, channel allocation, hand-offs

Cell Shape

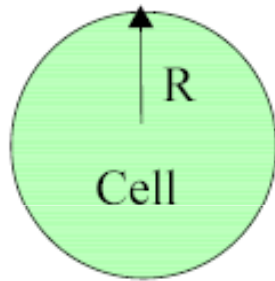

(a) Ideal cell



(b) Actual cell

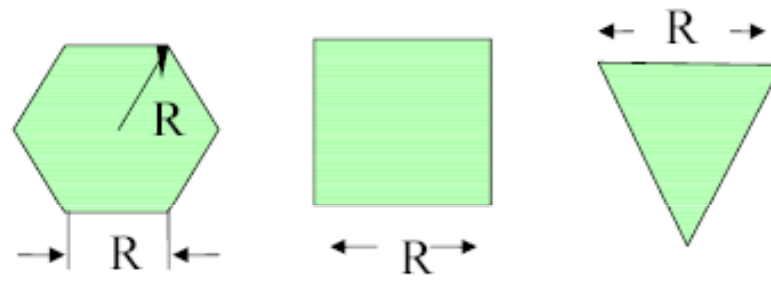

(c) Different cell models

Frequency Reuse

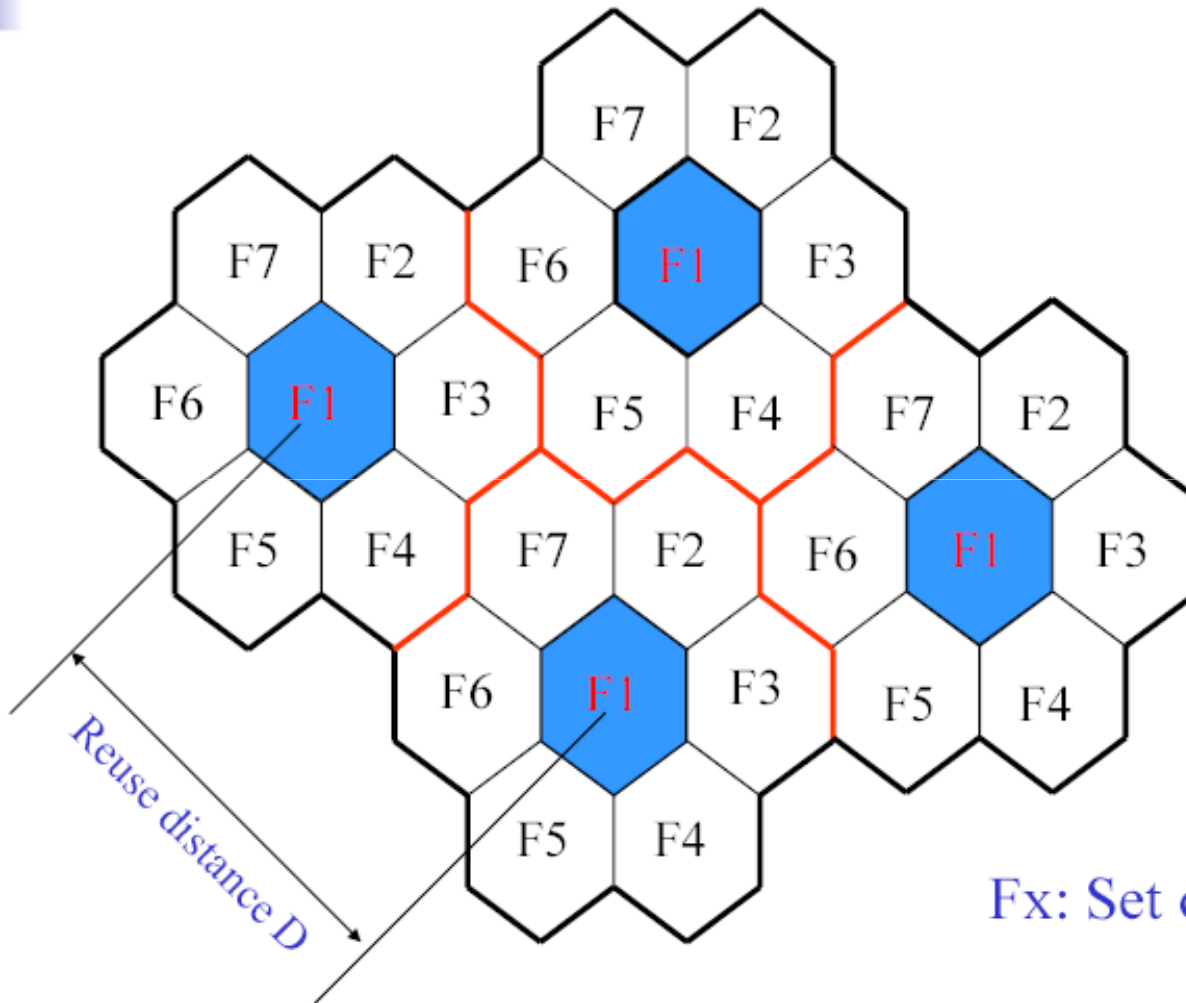

F_x : Set of frequency

7 cell reuse cluster

Reuse Distance

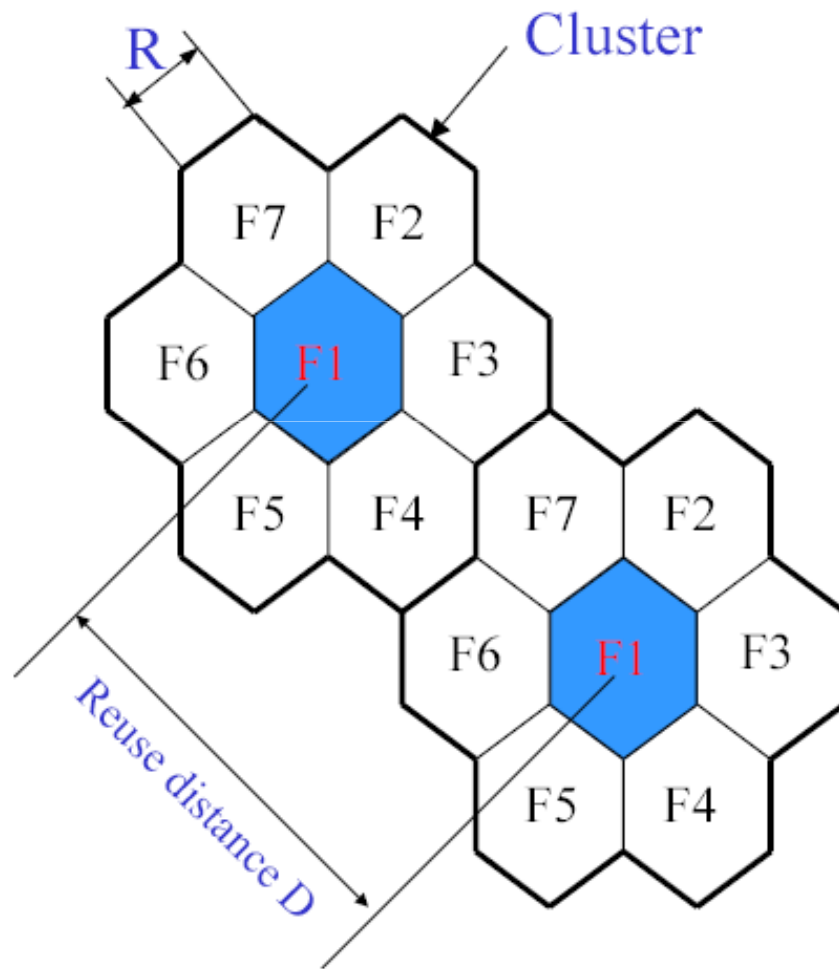

- For hexagonal cells, the reuse distance is given by

$$D = \sqrt{3NR}$$

where R is cell radius and N is the reuse pattern (the cluster size or the number of cells per cluster).

- Reuse factor is

$$\frac{D}{R} = \sqrt{3N}$$

Reuse Distance (Cont'd)

- The cluster size or the number of cells per cluster is given by

$$N = i^2 + ij + j^2$$

where i and j are integers.

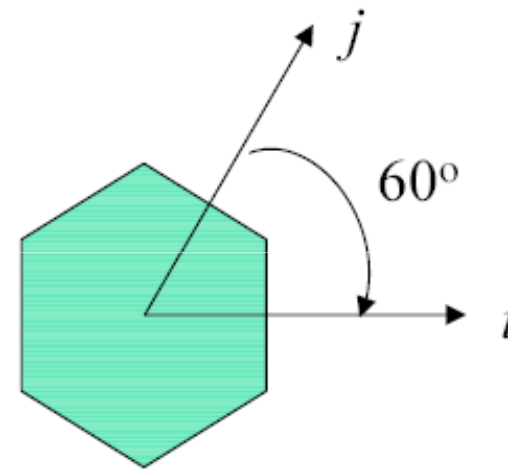

- $N = 1, 3, 4, 7, 9, 12, 13, 16, 19, 21, 28, \dots$, etc.

The popular value of N being 4 and 7.



Cochannel Interference

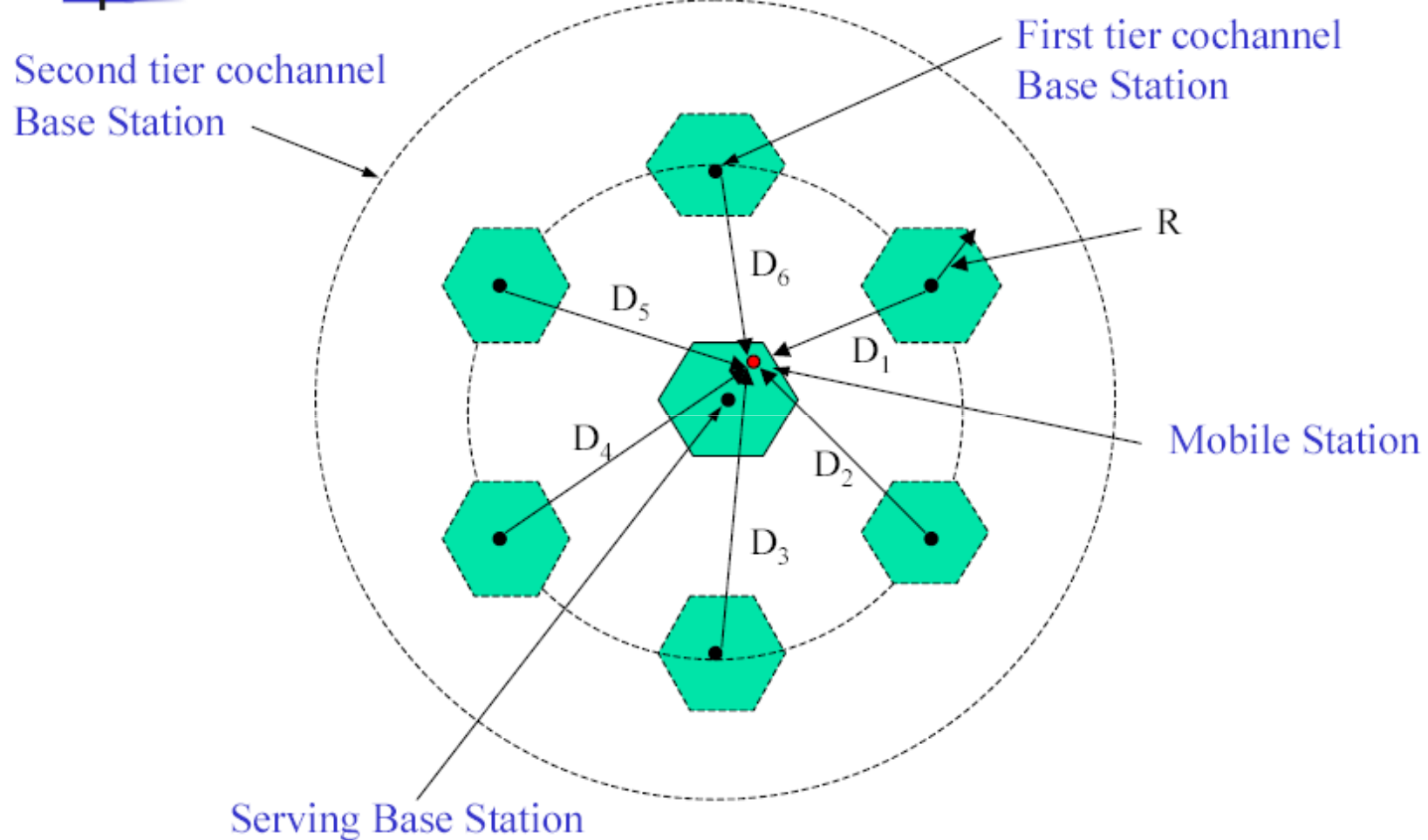

Worst Case of Cochannel Interference

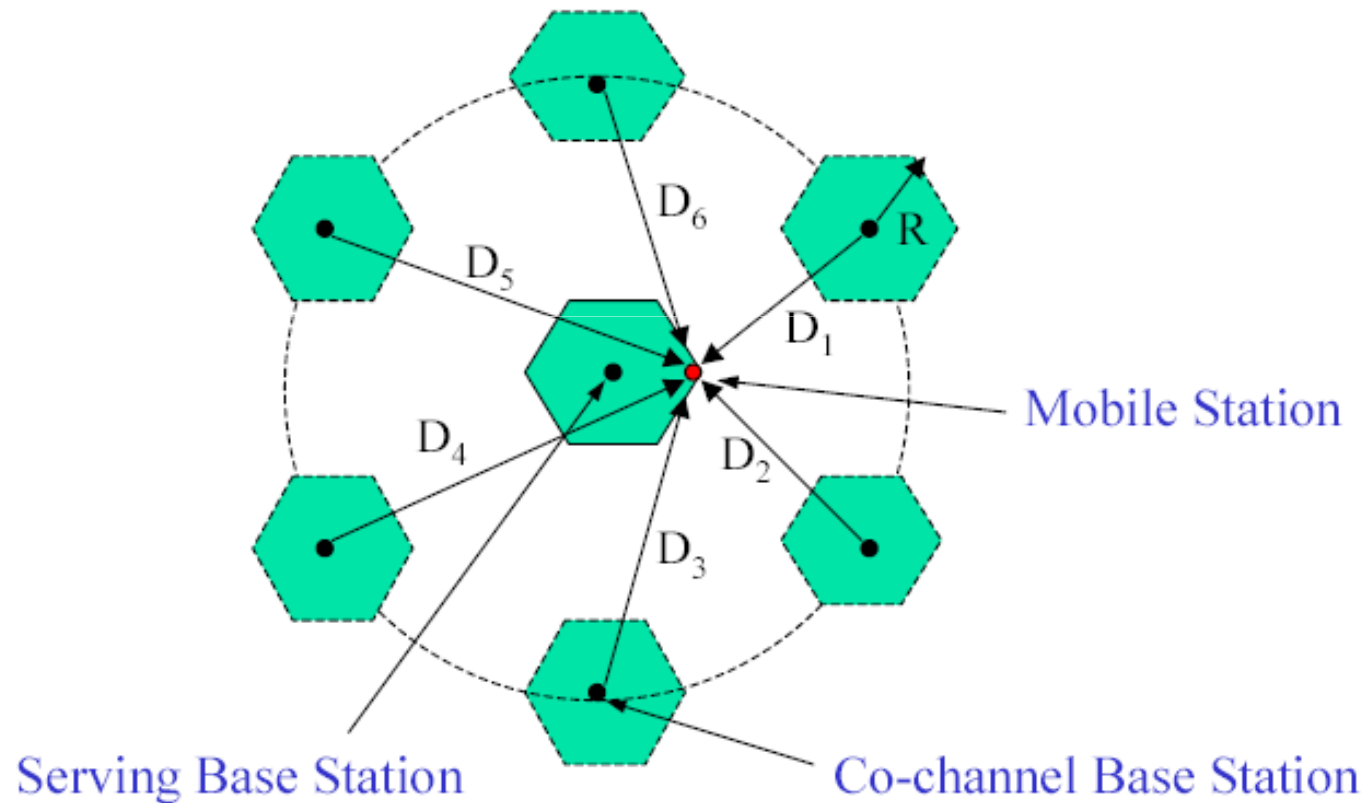

Cochannel Interference

- Cochannel interference ratio is given by

$$\frac{C}{I} = \frac{\text{Carrier}}{\text{Interference}} = \frac{C}{\sum_{k=1}^M I_k}$$

where I is co-channel interference and M is the maximum number of co-channel interfering cells.

For $M = 6$, C/I is given by

$$\frac{C}{I} = \frac{C}{\sum_{k=1}^6 \left(\frac{D_k}{R} \right)^\gamma}$$

where γ is the propagation path loss slope and $\gamma = 2 \sim 5$.

Channel Reuse

- ◆ The same channel is reused simultaneously by other sets (Co-channel)

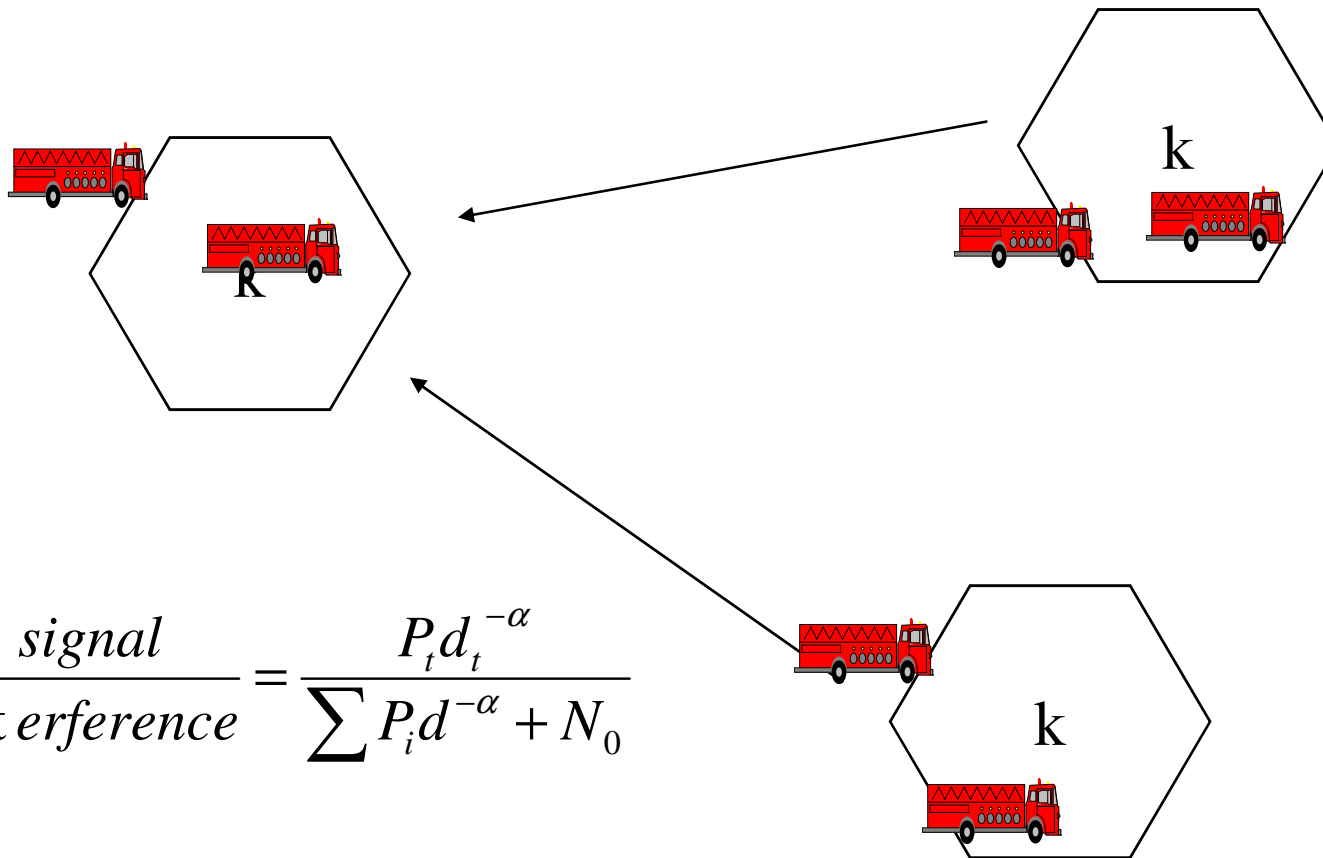

$$CIR = \frac{\text{signal}}{\text{interference}} = \frac{P_t d_t^{-\alpha}}{\sum P_i d_i^{-\alpha} + N_0}$$

Interference

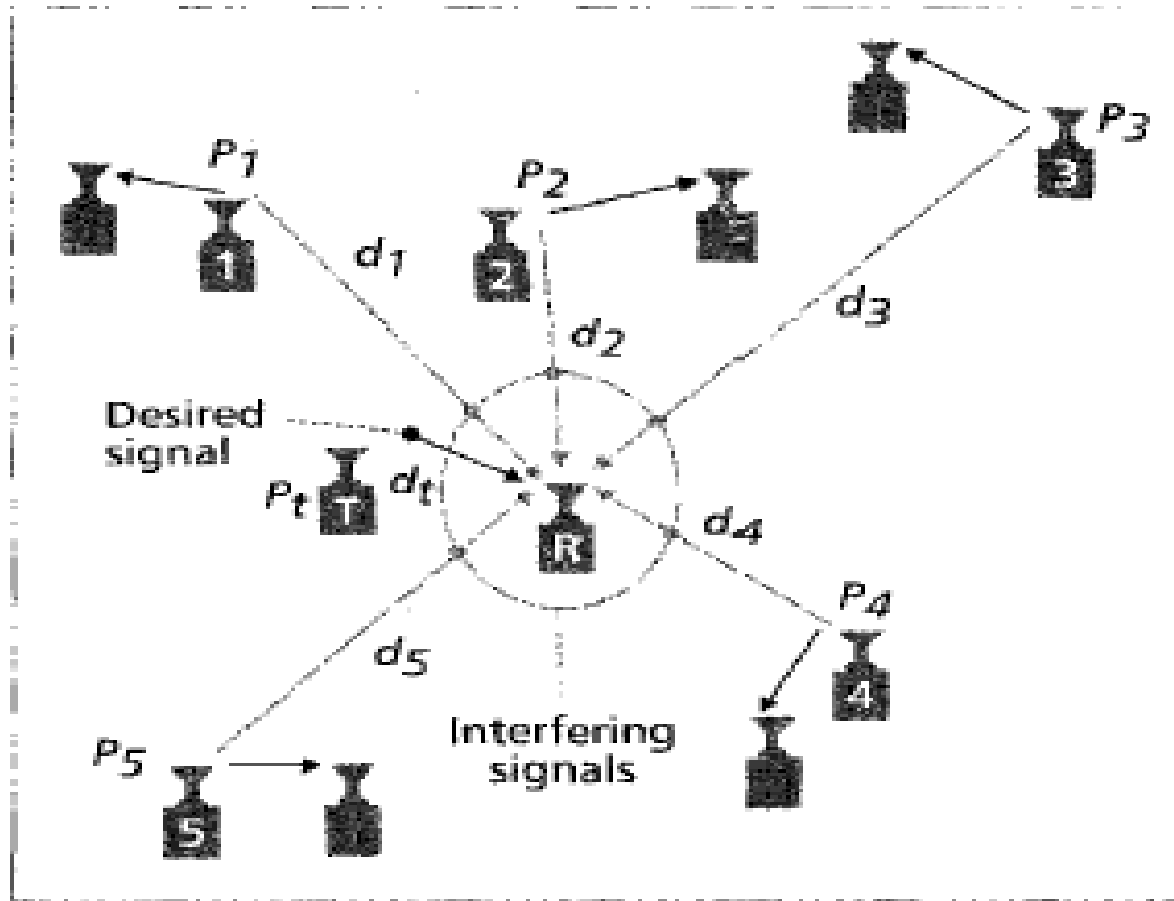

$$CIR = \frac{\text{signal}}{\text{int erference}} = \frac{P_t d_t^{-\alpha}}{\sum_1^5 P_i d_i^{-\alpha} + N_0}$$



How to improve CIR (Quality)

- ◆ Increase the transmitting power (Power Control)
- ◆ Increase the separating distance (Channel Reuse)

$$CIR = \frac{\text{signal}}{\text{int erference}} = \frac{P_t d_t^{-\alpha}}{\sum P_i d_i^\alpha N_0}$$

Approaches

- ◆ Fixed no flexibility
- ◆ Dynamic complexity
- ◆ Hybrid might be ok

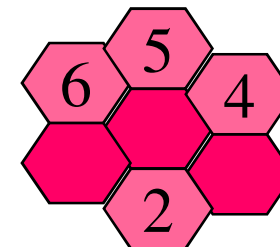
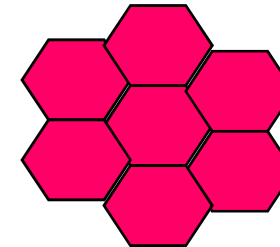
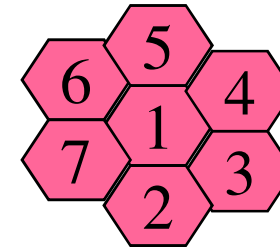

Frequency Reuse

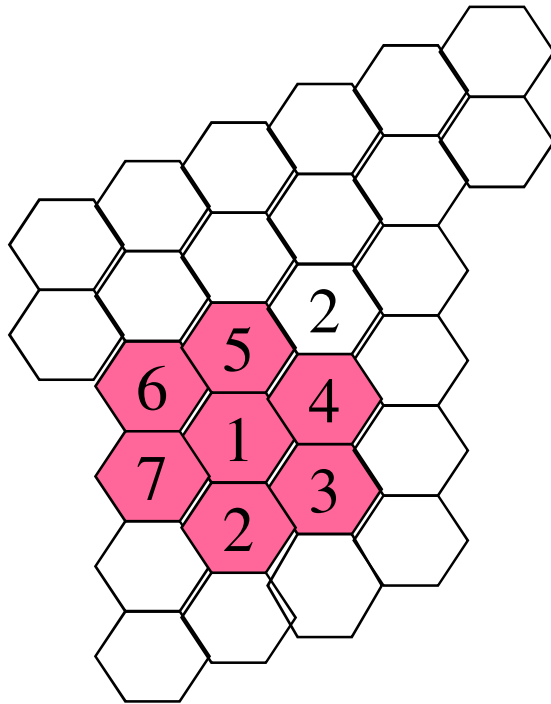

Idealized grid of
Hexagonal cells

- ◆ Each BS is allocated a subset of carrier freqs
- ◆ Nearby BSs are allocated a different subset to avoid interference
- ◆ The total set is allocated to a small tessellating group of N neighboring BSs
 - Called “reuse cluster”
 - $1/N$ is the “reuse factor”
 - System capacity goes up by $\frac{Area_{service}}{N \times Area_{cell}}$
- ◆ Used in FDMA & TDMA based systems
 - Not required in CDMA which has universal frequency reuse
- ◆ Cells idealized as hexagons
 - Real cell footprints are amorphous
 - Hexagon close to a circle
 - Not appropriate for micro-cells, highways etc.

Reuse Cluster For Hexagonal Cells

- ◆ A tessellating group of N hexagonal cells is possibly only iff

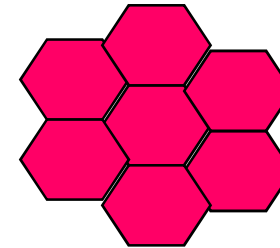
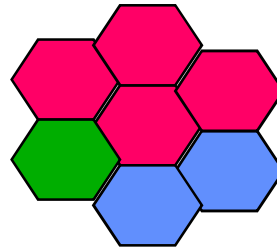
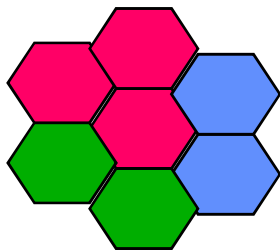

- ◆ Frequency Reuse Distance D
 - minimum distance between centers of co-channel cells
 - ◆ Depends on # of nearby cochannel cells, terrain, antenna height, transmit power etc.
 - for hexagonal cells, $D = R \sqrt{3N}$
 - ◆ Where, R is the radius of hexagon (center to vertices)
 - Increasing N , and therefore D , reduce co-channel interference (assuming R and transmit power are invariant)
 - D/R is called the co-channel reuse ratio

Determining Cluster Size

- ◆ If N is reduced while cell area is kept constant
 - more clusters needed to cover the service area
 - more channels per cell
 - more system capacity achieved
 - more co-channel interference as co-channel cells are closer
- ◆ Goal is to maximize system capacity (or, capacity per unit area) subject to interference limitations
 - Minimum N such that carrier-to-interference ratio
 - ◆ $C/I \geq (C/I)_{\min}$
 - Reverse co-channel interference
 - ◆ Interference at a BS from co-channel MHs in other BSs
 - Forward co-channel interference
 - ◆ Interference at a MH from other co-channel BSs
 - Adjacent channel interference
 - ◆ From signals in adjacent channel due to imperfect filters
 - ◆ Don't assign adjacent frequencies to the same cell and if possible immediate neighbors

Determining Cluster Size N

- ◆ Goal is maximize system capacity (or, capacity per unit area) subject to interference limitations
 - minimum N such that carrier-to-interference ratio
 - ◆ $C/I \geq (C/I)_{\min}$
 - reverse co-channel interference
 - ◆ interference at BS from co-channel MHs in other BSs
 - forward co-channel interference
 - ◆ interference at a MH from other co-channel BSs
 - adjacent channel interference
 - ◆ from signals in adjacent channels due to imperfect filters

Calculating C/I

- Let i_0 be the number of co-interfering cells, and noise be negligible

- C/I = Carrier / All of the co-channel interference
- Where C is the desired carrier power and I_i is the signal power of i-th interferer

$$\frac{C}{I} = \frac{C}{\sum_{i=1}^{i_0} I_i}$$

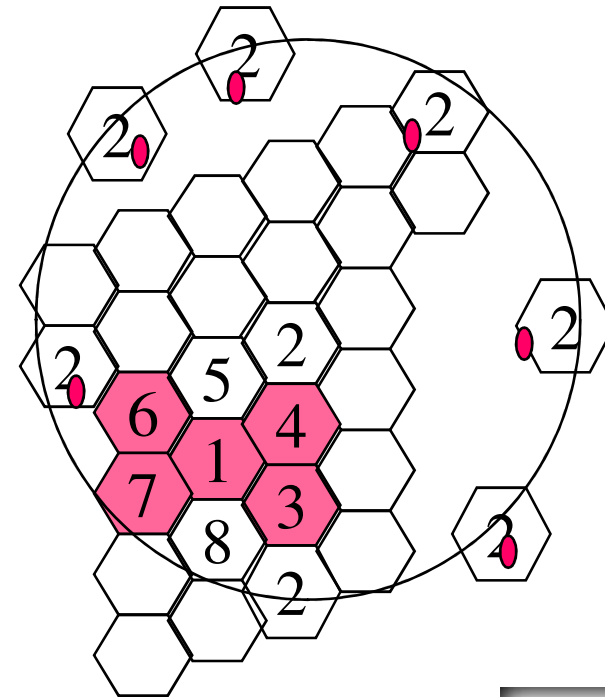
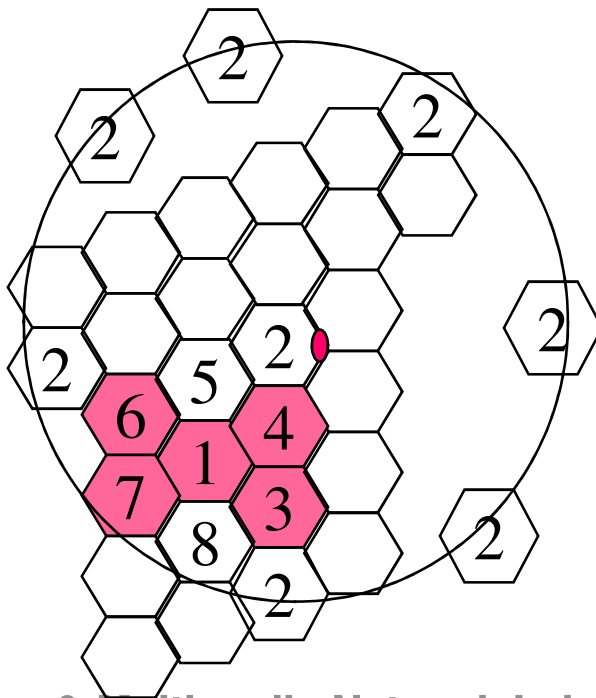

Calculating C/I

- ◆ Recall: $P_r(d) = P_r(d_0) \left(\frac{d}{d_0}\right)^n$
- ◆ For equal transmit powers and path loss exponents: $\frac{C}{I} = \frac{D_0^{-n}}{\sum_{i=1}^{i_0} D_i^{-n}}$
- ◆ Assume:
 - 1. $n=4$
 - 2. worst case is at $D_0 = R$ (when MH is at the fringe of its cell)
 - 3. only the six “first-tier” co-channel cells are considered
 - 4. $D_1 = D_2 = D_3 = D_4 = D_5 = D_6 = D$
- ◆ $C/I \sim (D/R)^4 / 6$ depends only on the ratio D/R

system	$(C/I)_{\min}$	D/R	N
AMPS	18 dB	4.6	7
GSM	11 dB	3.0	4

Microcells-Reducing Cell Area

- ◆ IF cell area is reduced while N is kept constant
 - more clusters needed to cover the service aread
 - C/I is unchanged because D/R is unchanged
 - system capacity grows quadratically with radius scale factor
- ◆ Small cells need lower RF transmitted power
 - longer battery, smaller mobile end-points
- ◆ Small cells result in higher cell-boundary crossing
 - more signalling overhead
 - performance degradation (more disruption)

Channel Assignment in Cellular System

- ◆ Fundamental Problem
 - How to assign channels to requesting call at a BS ?
- ◆ Goal: Maximum Spectral Efficiency for a specified grade of service and a given degree of computational complexity
 - probability of new call blocking
 - probability of forced termination
 - link quality
- ◆ Maybe a “new” connection, or a connection undergoing “handoff”

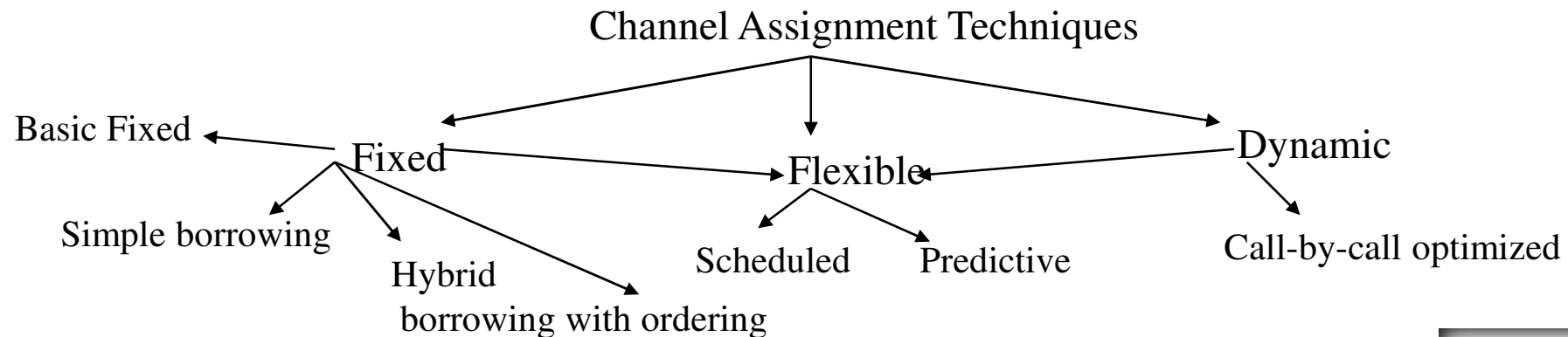

Channel Assignment Techniques

- ◆ Fixed
 - Basic Fixed
 - Simple borrowing
 - Hybrid borrowing with ordering
- ◆ Flexible
 - scheduled
 - predictive
- ◆ Dynamic
 - call-by-call optimized

Fixed Channel Assignment

- ◆ Basic strategy
 - each cell is statically allocated a subset of channels
 - a requesting call in the cell can only use channel allocated to that cell
 - if no available channel in that cell, the call is blocked
 - MSC only informs new BS about hand-off, & keep track of serving channel

Fixed Channel Assignment

- ◆ Variation
 - borrow channel from neighboring BSs if all channels busy at BS under MSC supervision, and only if does not cause interference borrowed channels are “locked”
 - hybrid channel assignment
 - ◆ two groups of channels: fixed and borrowable
 - ◆ ratio determined a priori depending on traffic estimate
 - borrow-with-channel-ordering
 - ◆ fixed-to-borrowable channel ration varied on changing traffic condition
 - ◆ channels are rank ordered

Fixed Channel Assignment

- ◆ We might borrow from neighboring cells

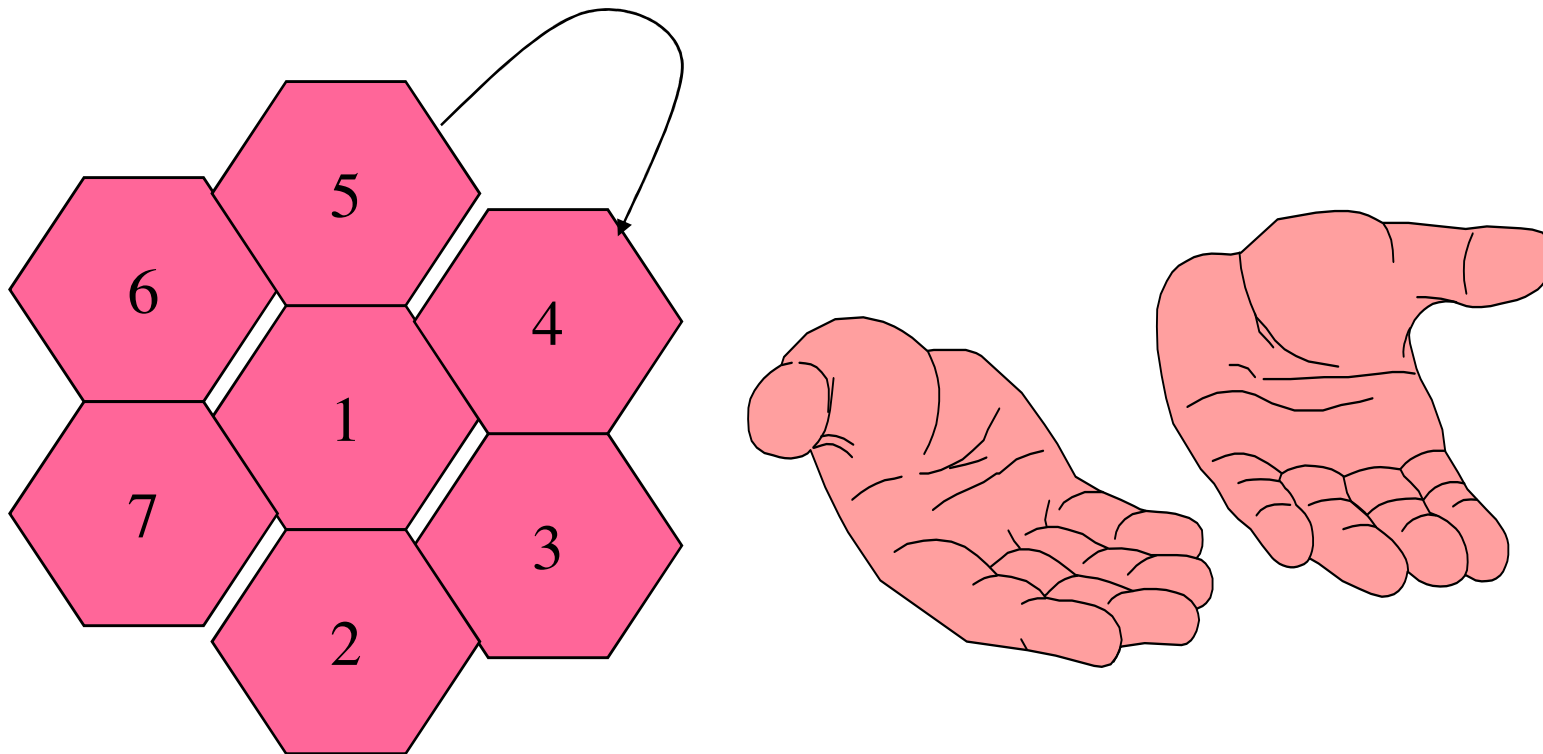

Traffic & Resource

- ◆ Uniform Distribution



Channel Resource



User Demanding

Dynamic & Assignment

- ◆ Maybe I should assign you based on current condition



Issues to consider



- ◆ Selected Cost
- ◆ Blocking Probability
- ◆ Reuse Distance
- ◆ CIR
- ◆ QoS (Quality of Service)
 - current value
 - handoff value

Dynamic Channel Assignment (DCA)



◆ Basic Features

- channels not allocated to cells permanently
- MSC allocated channel to a call from the global pool taking into account
- Advantage: channel assignment may be retained across hand-off
- Disadvantage: interruptions, deadlocks, instability

Dynamic Channel Assignment

- ◆ DCA algorithms differ in distribution of control among BSs and MSC
 - Centralized DCA
 - ◆ can do a globally optimized channel assignment and call rearrangement BSs need to communicate with MSC e.g. Maximum Packing
 - Decentralized & Fully Decentralized DCA
 - ◆ rely only on local monitoring to make channel assignments
 - ◆ require limited local communication among cluster of BSs

Flexible Channel Assignment

- ◆ Combine aspects of FCA and DCA
- ◆ Each cell is assigned a fixed set of channel
- ◆ Plus, a pool of channels is reserved for flexible assignment
 - MSC assigns these channels
- ◆ Flexible assignment strategies
 - Scheduled assignment: rely on known foreseeable changes in traffic pattern
 - Predictive assignment: based on measured traffic load at every BS

MSC will pick up one for MH

- ◆ Here you go !



Flexible Channel Assignment

- ◆ Assign some of channel for minimum traffic requirement
- ◆ Keep all of the others in a service pool

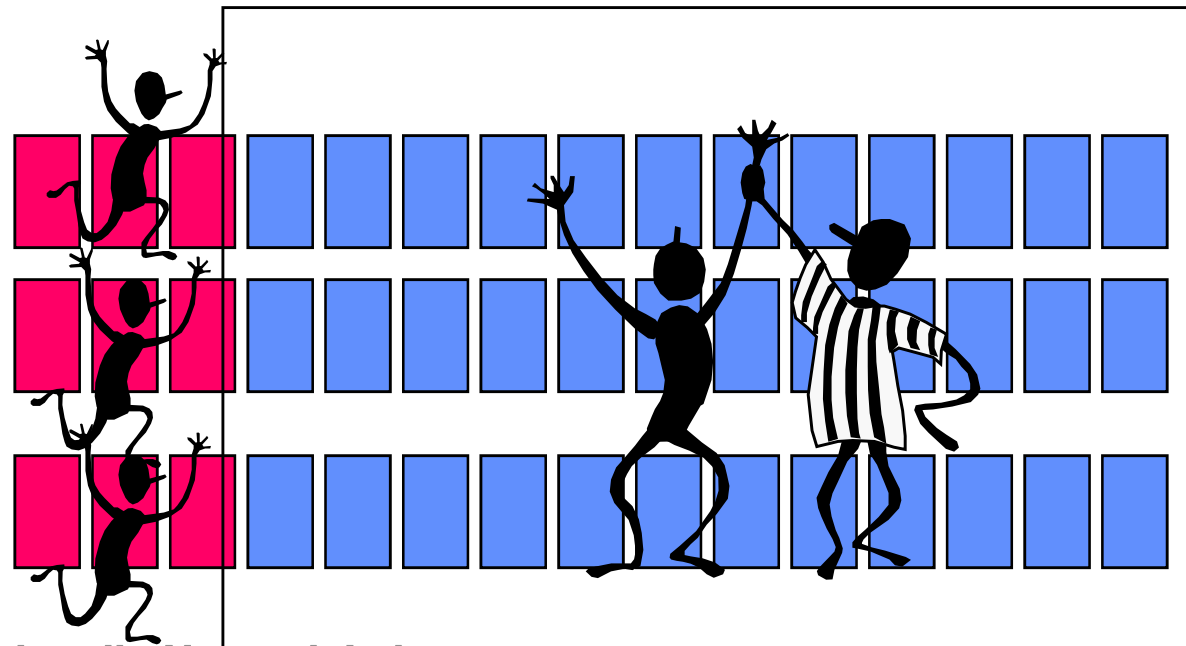

Handoff Handling



Keep the QoS while the user moves

Handling Handoffs

- ◆ Handoff
 - change the radio channel
 - ◆ the same base station
 - ◆ the new base station
 - due to
 - ◆ the radio link degradation
 - ◆ channel reorder

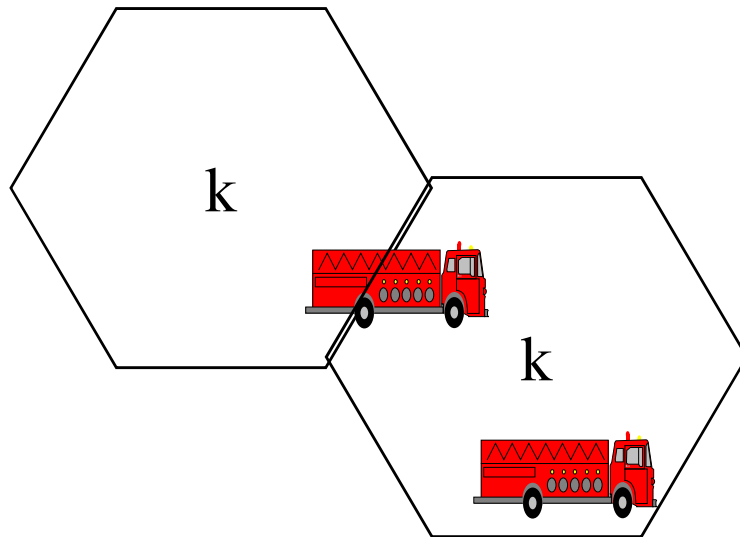

What is going to happen ?

- ◆ The new cell must assign new channel
- ◆ We must reserve some hand off channel
- ◆ Some connection must be blocked !!

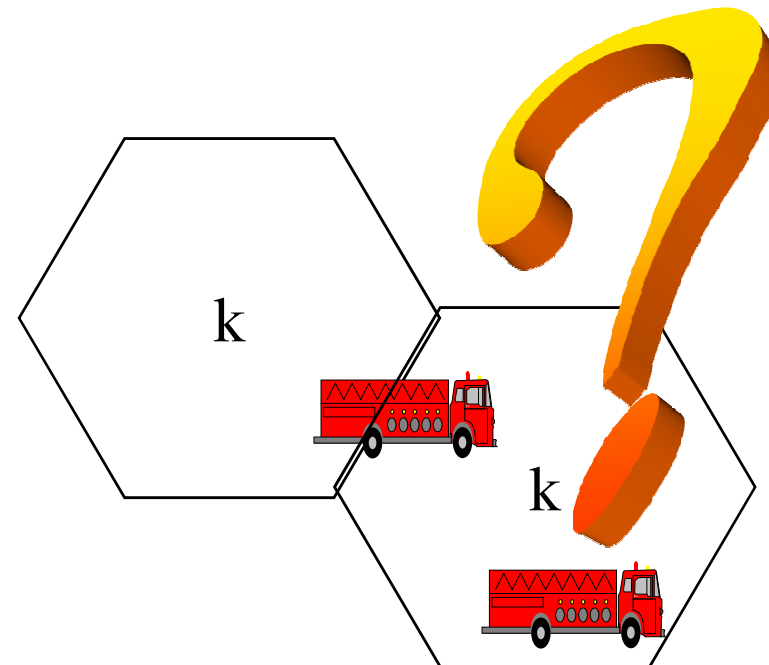

Solutions for handoff

- ◆ Handoff Priority
 - guard channel for handoff
 - how much, inefficiency
- ◆ Queueing of Handoff request
 - take a seat for future handoff

Guard Channel

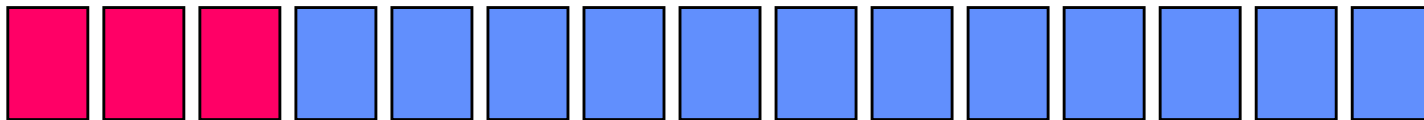

Reserved for Handoff

Thresholds

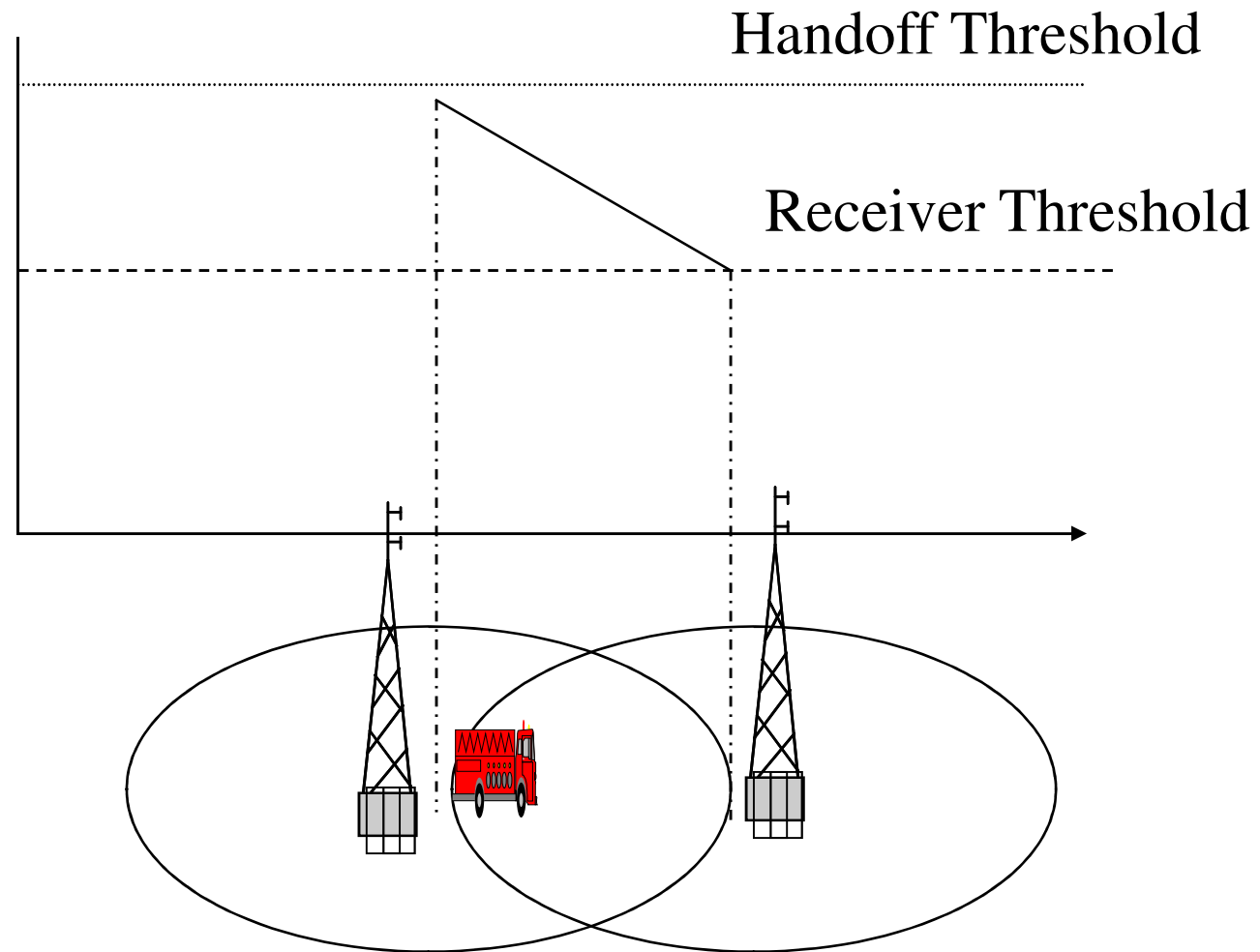

Who is going to take over Handoff

- ◆ Yourself (Mobile Users)
- ◆ Infrastructure Network
 - Base Station
 - Mobile Switching Center

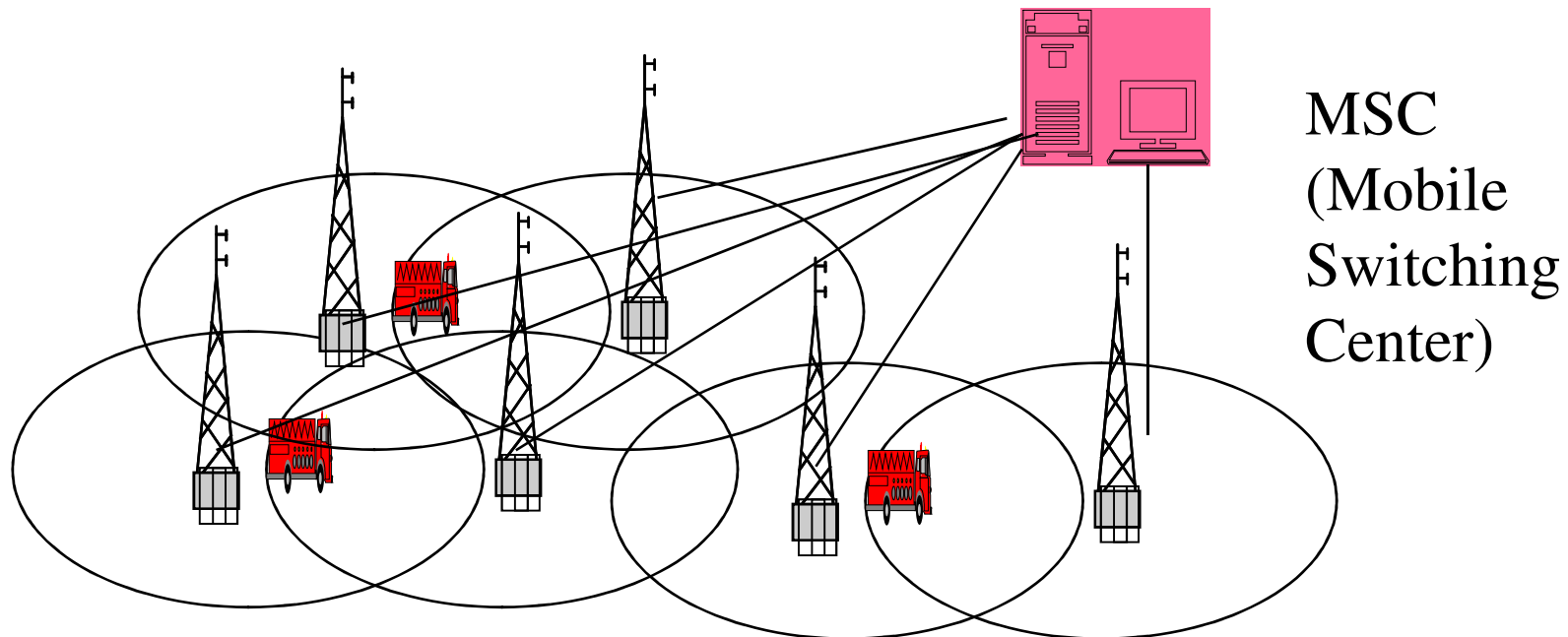

Negotiating Procedure

- ◆ Base Station
 - detect the receiving signal from MH
 - send a measurement order
- ◆ Mobile Host
 - measure on demand
 - measure all the time

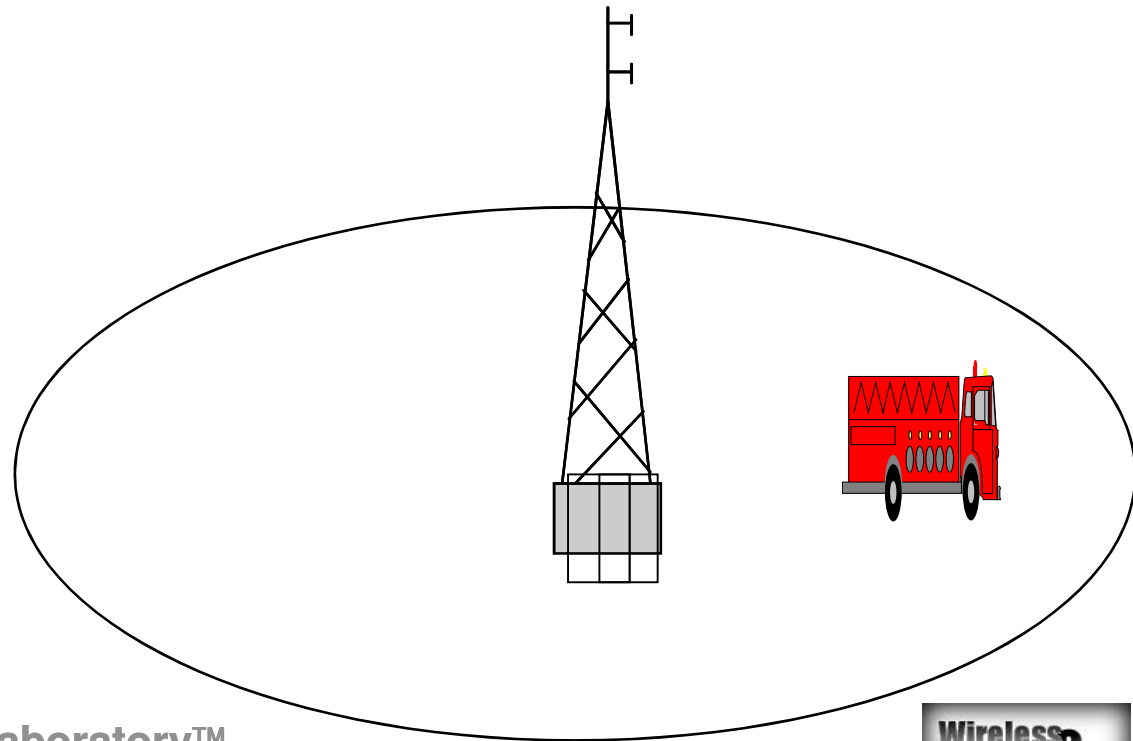

Hand off Procedure

- ◆ Decide the New Base Station
 - MSC picks the best for MH
 - MSC picks the candidate MH specify
- ◆ New Base Station decides to accept or not ?

Call Queueing Scheme

- ◆ Queue for a channel, handoff threshold, receiver threshold

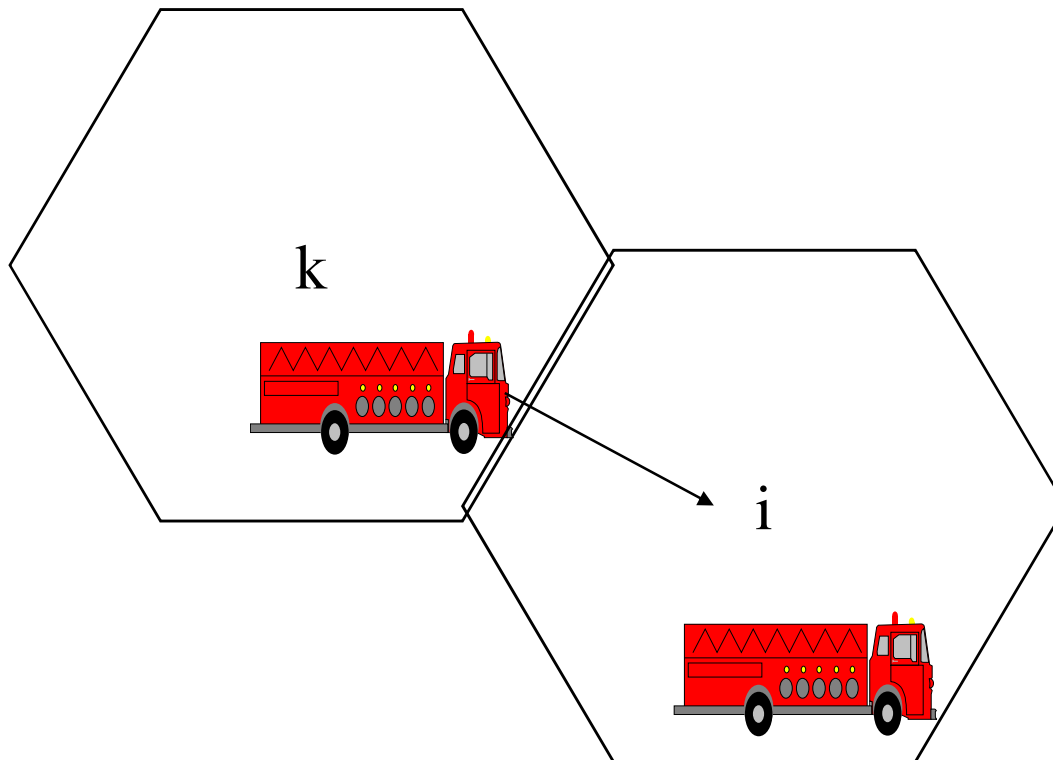

Trends in Hand over Design

- ◆ Hand over and Hand off are the same
- ◆ Small cells -> more hand over
 - allocate network resource to reroute the call to the new base station
 - if not quick enough, QoS will drop dramatically

QoS \longleftrightarrow Hand off

Mobility Solution

- ◆ Multi-tiers
 - micro-cell and macro-cell
 - based on the speed
 - different schemes

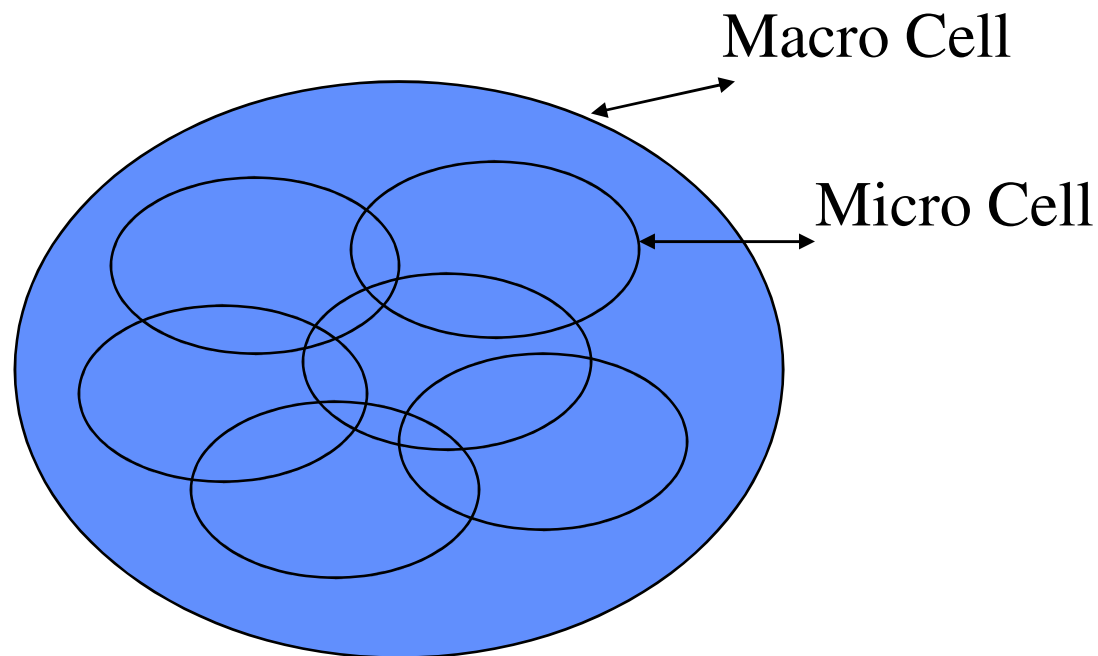

Velocity Estimation

- ◆ Doppler Frequency is known -> Estimation of the velocity of the mobile users
- ◆ Mobility is estimated from the time spent in a cell

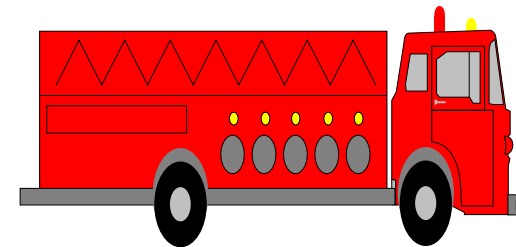
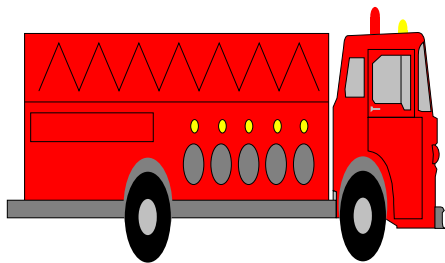

Handoff in Cellular Networks

- ◆ Transfer of mobile to a new channel when it crosses cell boundary
 - identify new base station, assign new channel
 - hand-off initiated at a carefully chosen signal level
 - avoid triggering handoff due to momentary fades

Hand-off

- ◆ Handoff delay & interruption
 - dropped (or on hold) connection if signal too low before handoff processed
 - performance degradation (disruption) in data stream
- ◆ Prioritizing handoffs to reduce probability of dropped call
 - connection dropped if no spare channels in new cell
 - guard channel : subset of channels reserved for handoff requests works well with DCA
 - handoff queuing : time interval between handoff trigger & connection drop
cell overlap, speed of mobile

Handoff in Cellular Networks

- ◆ Probability of unnecessary Handoffs
- ◆ Hard vs. Soft handoff
- ◆ Hand off rate
- ◆ Handoff also triggers rerouting in the network layer
- ◆ Handoff is tightly coupled to DCA, MAC, and Networking Routing

Handoff Strategies (I)

- ◆ Network controlled handoff (NCHO)
 - used in first generation analog cellular systems
 - link quality is only monitored by the serving BS and surrounding BS
 - handoff decision is made by the network (typically central agent)
 - handoff delays of several seconds (10) and infrequent link quality updates



Handoff Strategies (II)

- ◆ Mobile assisted handoff
 - used in second generation digital cellular system
 - both the mobile and the serving BS measure link quality
 - only mobile measures link quality of alternate BSs
 - mobile periodically sends the link quality measurements to serving BS
 - handoff decision is made by the network
 - handoff delays of few seconds (1-2) and frequent link quality updates

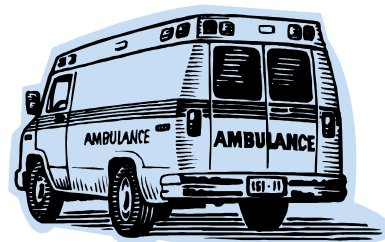

Handoff Strategies (III)

- ◆ Mobile controlled hand off
 - used in some new digital cellular systems
 - link quality measurements as in MAHO
 - serving BS relays link quality measurements to mobile
 - handoff decision is made by the mobile
 - handoff delays of about 100 ms



Handoff Scenario

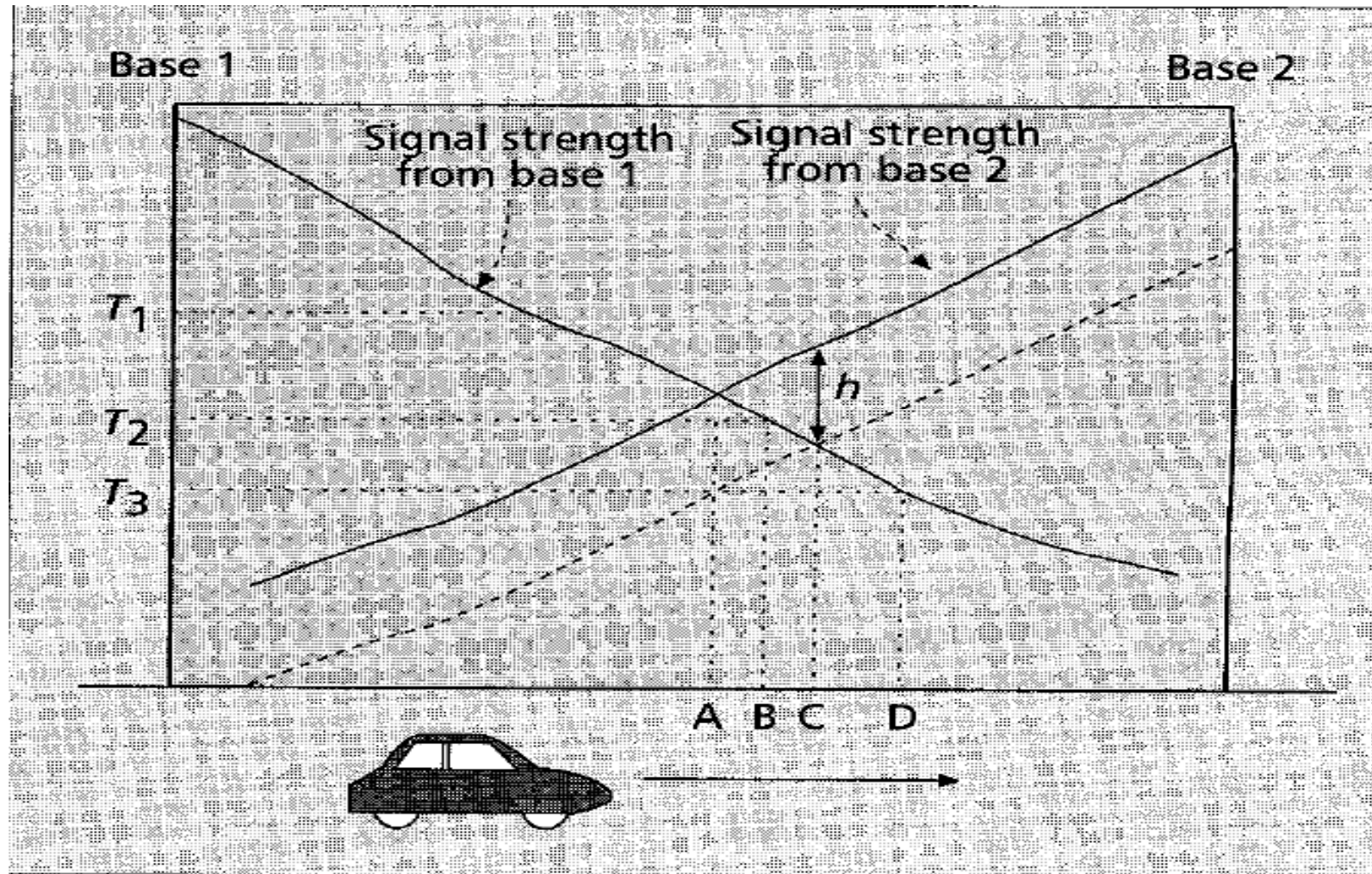

Handoff Initiation Strategies

- ◆ Relative signal strength
 - Always choose the strongest received BS
 - Too many unnecessary hand-offs
- ◆ Relative signal strength with threshold
 - Current signal $<$ threshold, and other BS is stronger
 - May let MH stray too far into other cell; overlapping cell coverage
 - Effectiveness depends on knowledge of cross-over signal
- ◆ Relative signal strength with hysteresis (plus optionally dwell timer)
 - Hand-off only if new BS's signal is stronger by a hysteresis margin
 - Prevents ping-pong effect from rapid fluctuations
- ◆ Relative signal strength with hysteresis & Threshold
 - Hand-off only if current BS's signal below a threshold, and new BS's signal is stronger by the hysteresis margin
- ◆ Prediction techniques
 - Decide based on expected future value of received signal strength

Handoff Queueing

- ◆ Goal is to reduce handoff failure probability
 - Better to block a new call than to drop an existing one
 - Exploits overlap between cells to queue hand-off request in advance

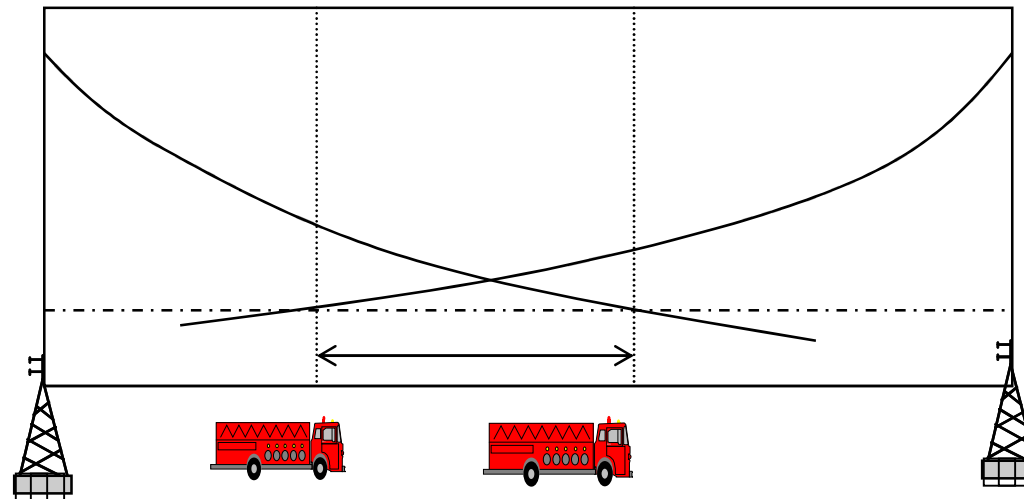

- ◆ Handoff request is issued according to handoff initiation strategy
 - Request is queued
 - Decision must be made (handoff or failure) while MH still in handoff interval



Cell Splitting

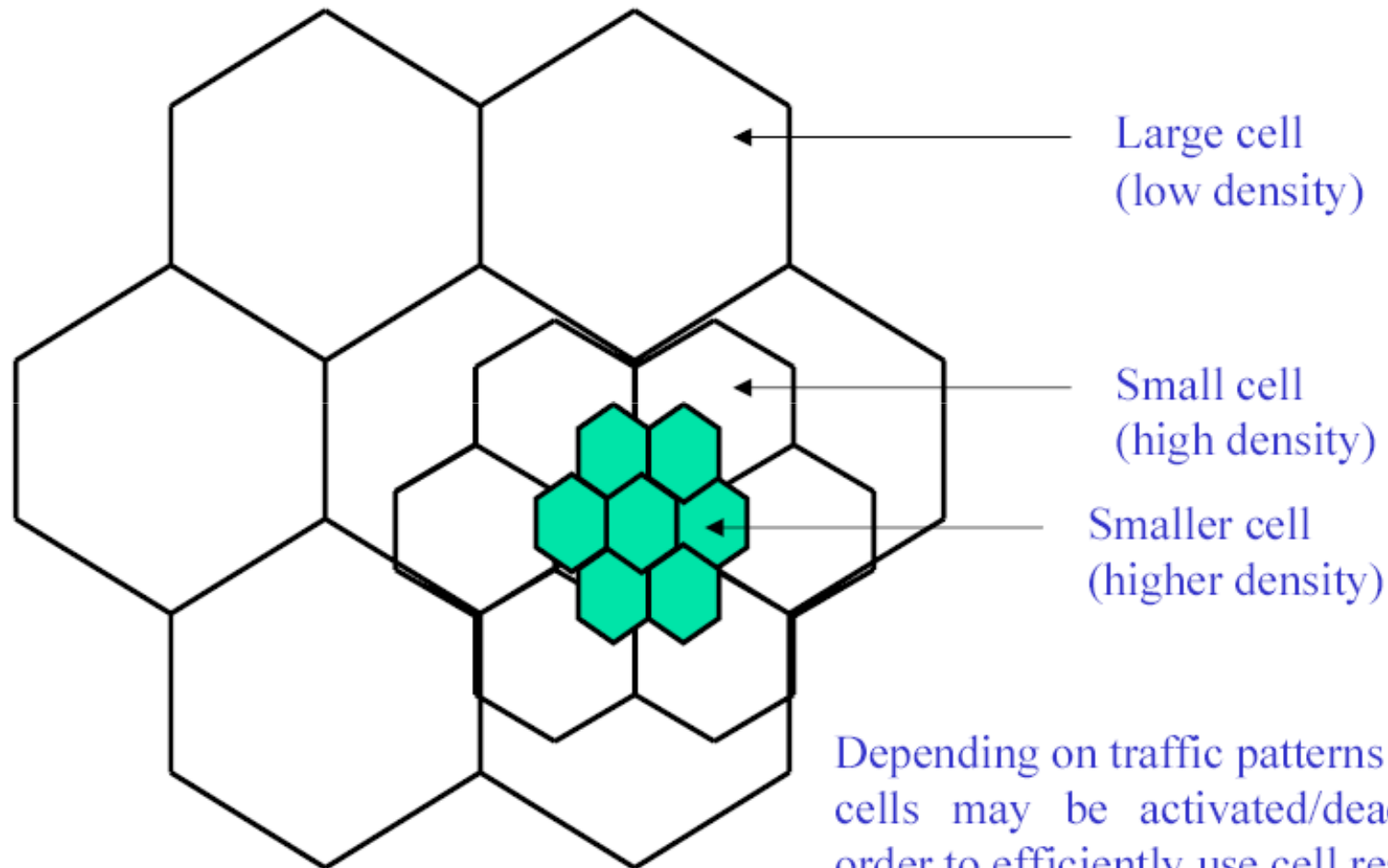

Cell Sectoring by Antenna Design

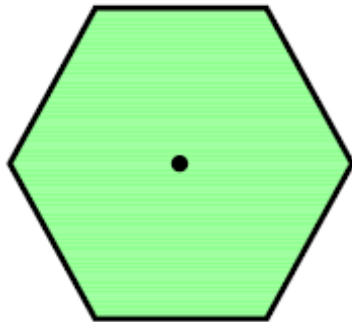

(a). Omni

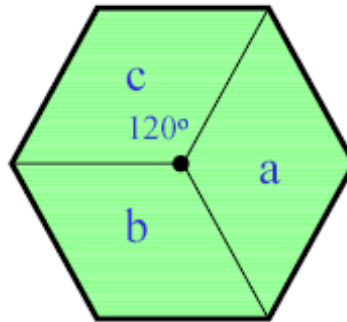

(b). 120° sector

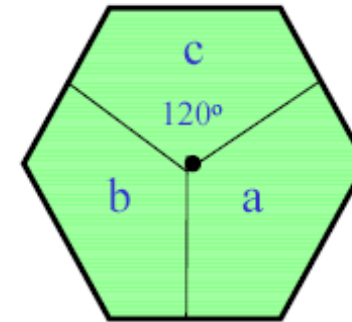

(c). 120° sector (alternate)

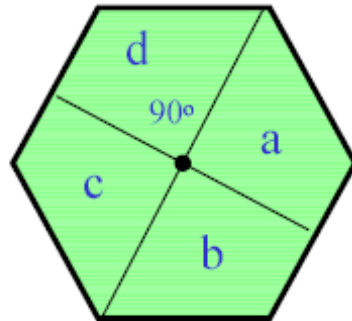

(d). 90° sector

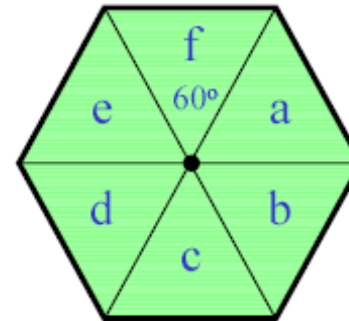

(e). 60° sector

Cell Sectoring by Antenna Design

- Placing directional transmitters at corners where three adjacent cells meet

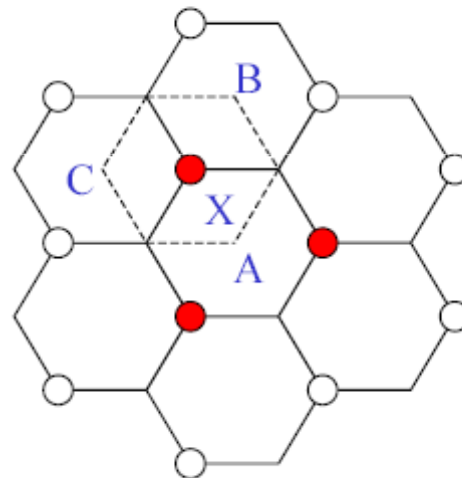

Worst Case for Forward Channel Interference in Three-sectors

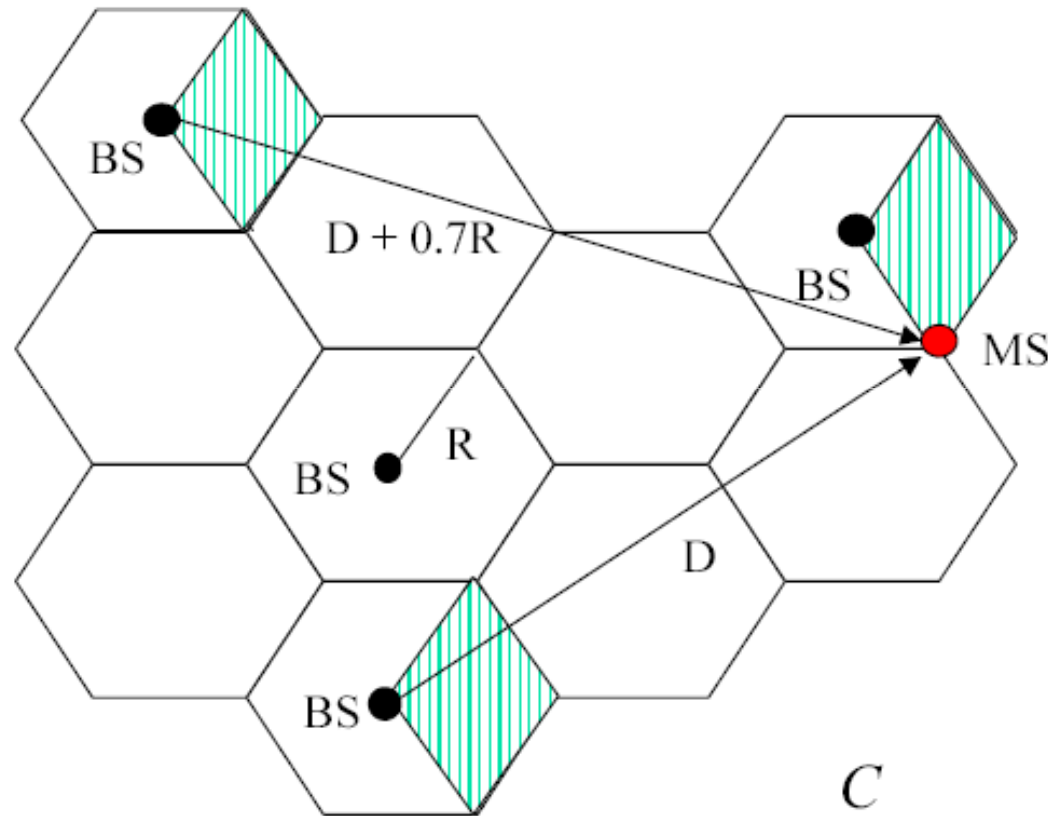

$$\frac{C}{I} = \frac{C}{q^{-\gamma} + (q + 0.7)^{-\gamma}}$$

Worst Case for Forward Channel Interference in Six-sectors

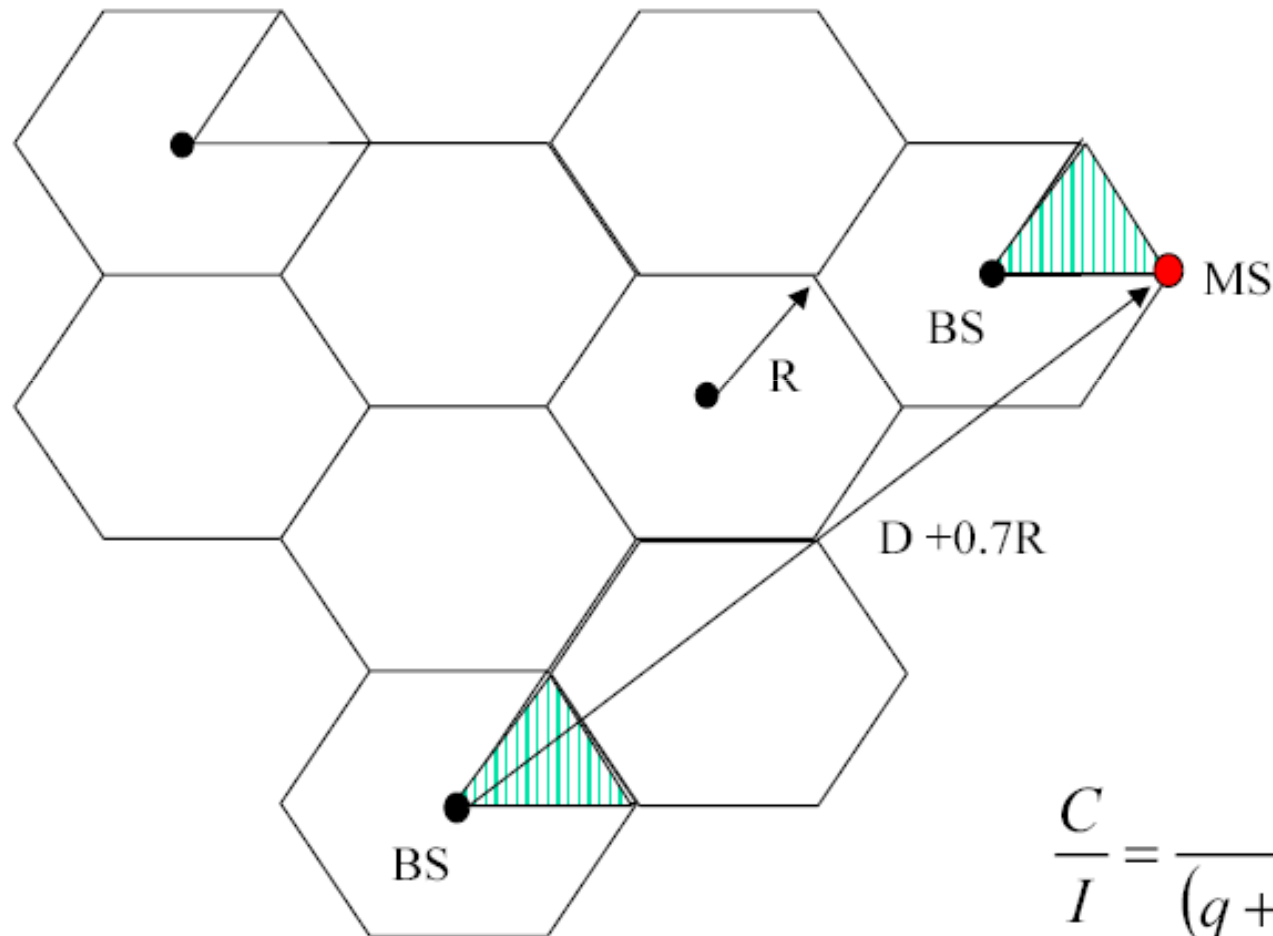

$$\frac{C}{I} = \frac{C}{(q + 0.7)^{-\gamma}}$$

Handoff Parameters



Mobility Support~ Handover

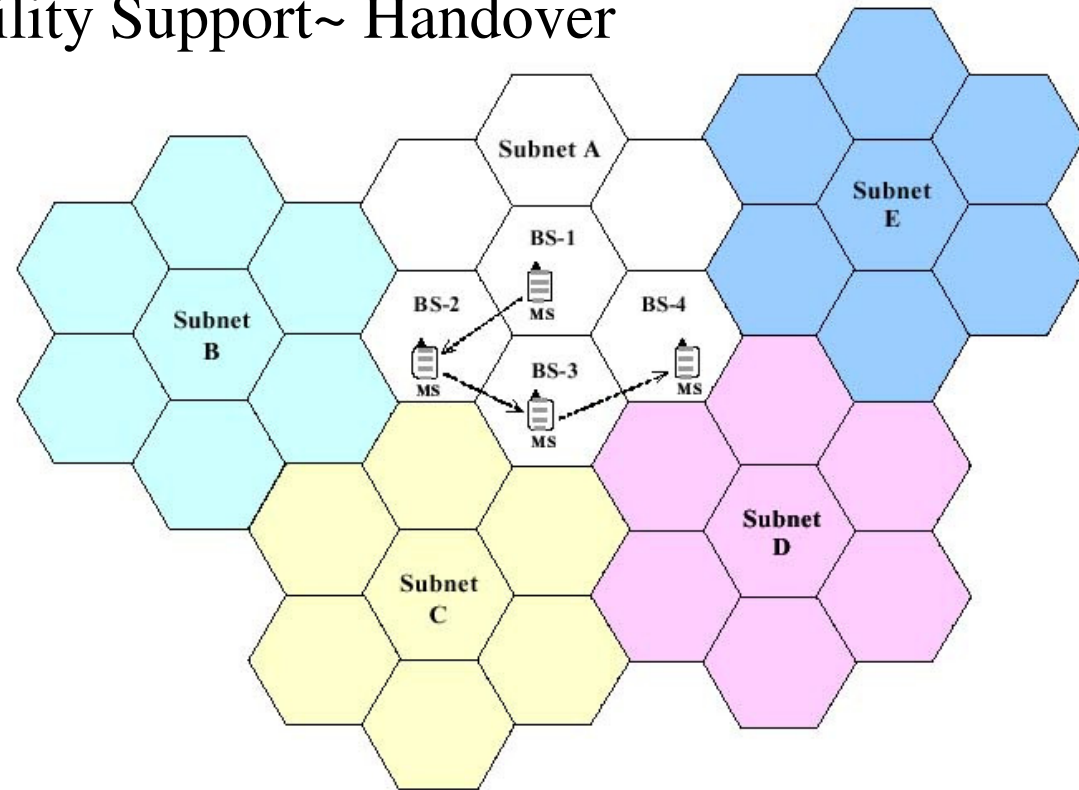

Channel Allocations: Reuse

Performance Index

- ◆ Traffic Request: (QoS)
 - New Call Probability
 - Handoff Call Probability
 - Traffic Requirements (Bandwidth, delay)
 - Call Holding Time
 - Dwell Time (Channel Occupation) for a handoff call or new call
 - Delay/Distance/Un-necessary handoff
- ◆ Mobility:
 - Resident time in a cell
 - Hand off rate
- ◆ Channel Resource:
 - Channel assignment
 - Blocking Rate (New Call blocking rate, Handoff blocking rate)

IP-based 3G Wireless Network

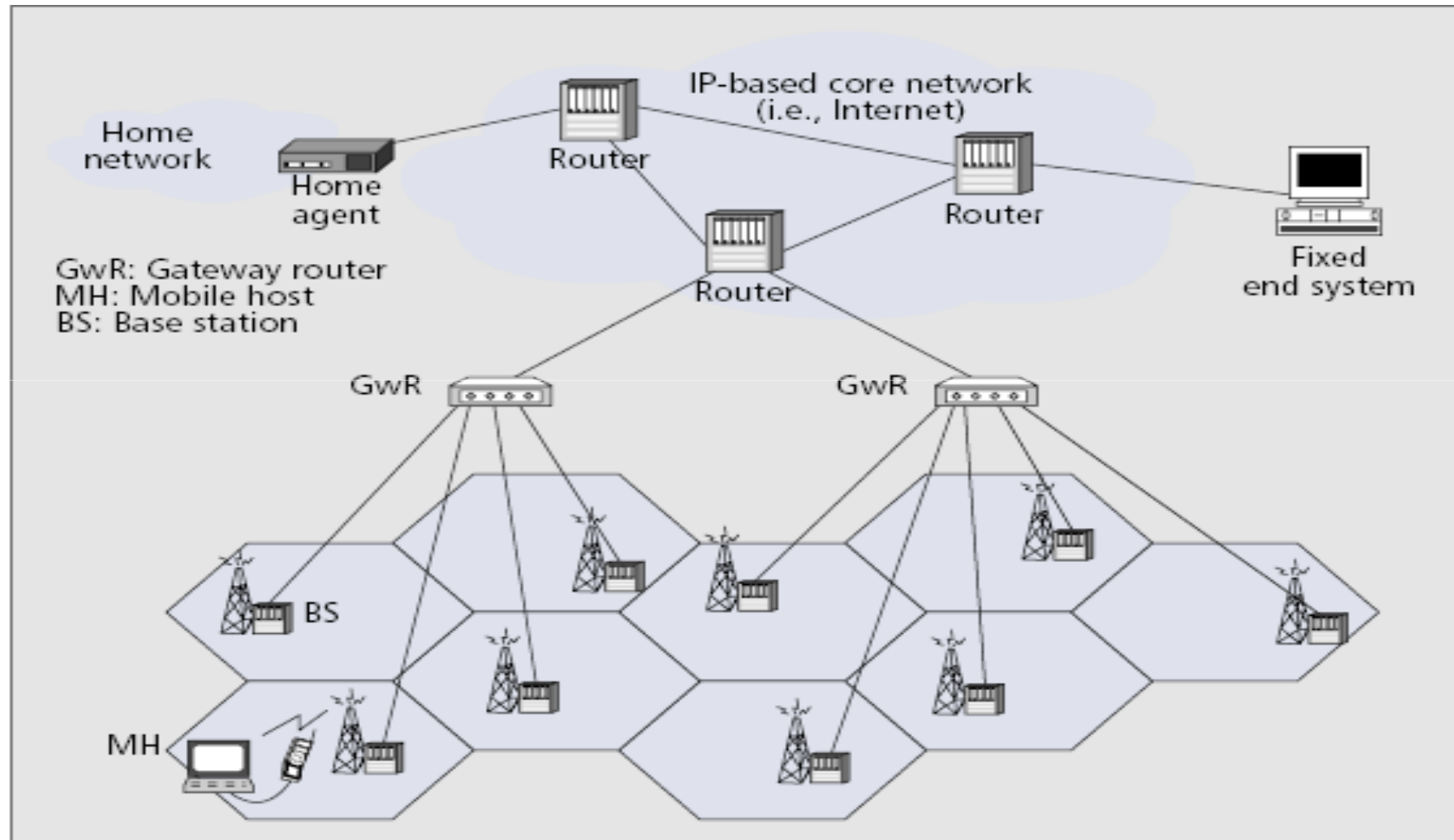

Multi-path Effect (Time)

- ◆ RMS > Symbol Duration:
 - ISI (handled by Equalizer)
- ◆ RMS < Symbol Duration:
 - More than one paths signal arrive (might have different phases)

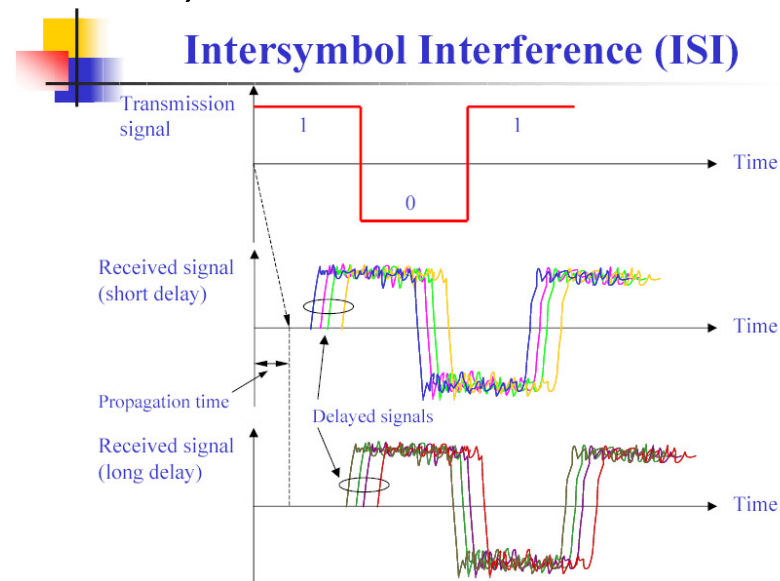

Coherence Bandwidth (Bandwidth)

- ◆ Coherence Bandwidth $<$ BW of signal:
 - Frequency Selective Fading
- ◆ Coherence Bandwidth $>$ BW of signal:
 - Flat Fading

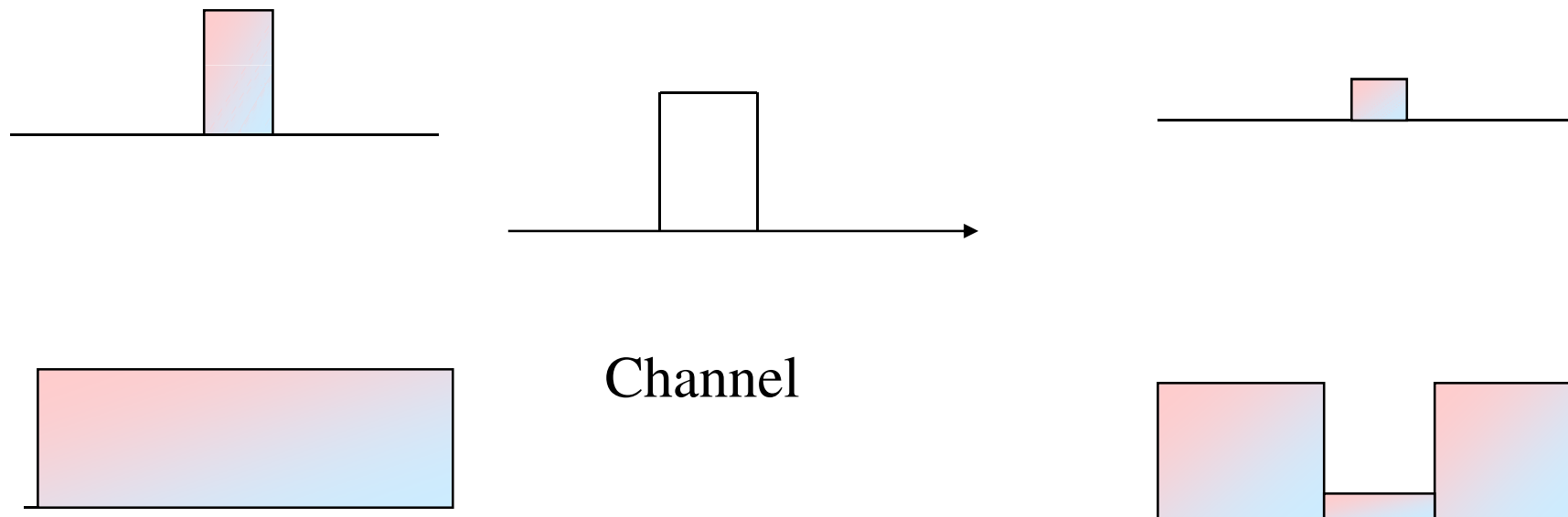

BS and BS list in MS

