

CS/E

## 無線網路多媒體系統 Wireless Multimedia System



**Dr. Eric Hsiackuang Wu**  
WiMAX & UWB

無線網路多媒體實驗室  
Wireless Network & Multimedia Laboratory

Wireless & Multimedia Network Laboratory™

Wireless Multimedia

CS/E

## WiMAX Consumer Last Mile

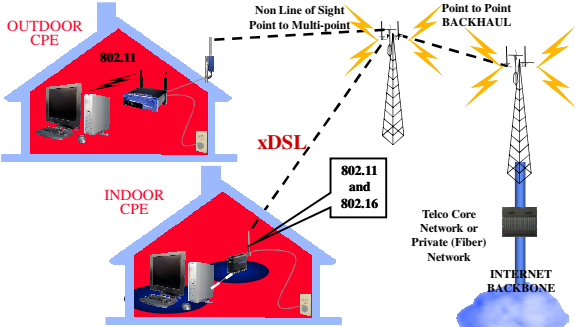

Ref: Margaret LaBrecque, "Enabling Deployments through Standards and Certification," WiMax, 2003

Wireless & Multimedia Network Laboratory™

18

CS/E

## WiMAX Nomadic and Portable



Ref: Margaret LaBrecque, "Enabling Deployments through Standards and Certification," WiMax, 2003

Wireless & Multimedia Network Laboratory™

19

CS/E

## Wearable Computing

- ◆ Traditional Scenario
  - People wear sensors now routinely
  - Primarily for fashion or as indicators
- ◆ Wearable computing
  - Interaction with computer or other personal device
  - Interaction in an intelligent environment
  - Interaction with other people



Wireless & Multimedia Network Laboratory™

Wireless Multimedia

CS/E

## What is Ultra Wideband?

- ◆ Originally referred to
  - "baseband", "carrier-free", or impulse
- ◆ Any wireless transmission scheme
  - occupies a bandwidth of more than 25% of a center frequency, or more than 1.5GHz

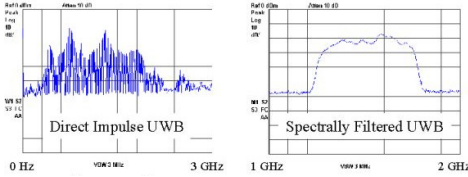

Wireless & Multimedia Network Laboratory™

Wireless Multimedia

CS/E

## Compare with IEEE 802.11 and Bluetooth

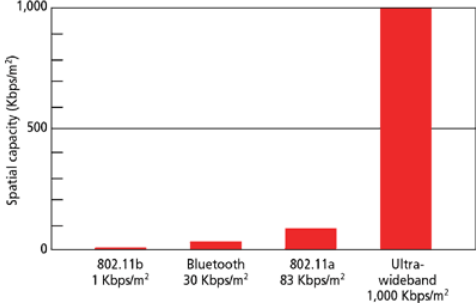

Wireless & Multimedia Network Laboratory™

Wireless Multimedia

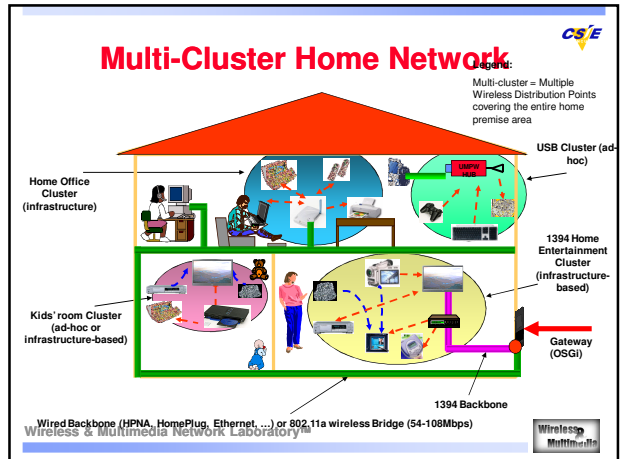
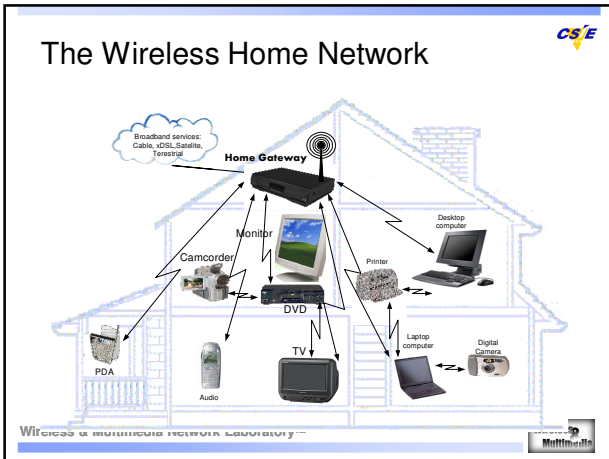

## Topic I

### WiMAX: IEEE 802.16

Professor Eric Hsiaokuang Wu  
June 10, 2005

Wireless & Multimedia Network Laboratory™

## Broadband Access to Buildings

- ◆ The "Last Mile"
  - Fast local connection to network
- ◆ Business and residential customers demand it
  - Data, voice, video distribution, real-time video conferencing
- ◆ Network operator demand it
- ◆ High capacity cable/fiber to every user is expensive

Wireless & Multimedia Network Laboratory™

## Introduction

- ◆ Goal: Provide high-speed Internet access to home and business subscribers, without wires.
- ◆ Base stations (BS) can handle thousands of subscriber stations (SS)
- ◆ Access control prevents collisions.
- ◆ Supports
  - Legacy voice systems
  - Voice over IP
  - TCP/IP
  - Applications with different QoS requirements

Wireless & Multimedia Network Laboratory™

## Introduction

- ◆ 802.16 standards:
  - 802.16.1 (10-66 GHz, line-of-sight, up to 134Mbit/s)
  - 802.16.2 (minimizing interference between coexisting WMANs.)
  - 802.16a (2-11 GHz, Mesh, non-line-of-sight)
  - 802.16b (5-6 GHz)
  - 802.16c (detailed system profiles)
  - P802.16e (Mobile Wireless MAN)

Wireless & Multimedia Network Laboratory™

## Point to Multipoint

CS/E

- ◆ BS connected to public networks
- ◆ BS serves Subscriber Station (SSs)
  - SS typically serves a building (business or residence)
  - Provide SS with first-mile access to public networks
- ◆ Compared to a Wireless LAN
  - Multimedia QoS, not only contention-based
  - Many more users
  - Much higher data rates
  - Much longer distances

Wireless & Multimedia Network Laboratory™

Wireless  
Multimedia

## WirelessMAN: Wireless Metropolitan Area Network

E

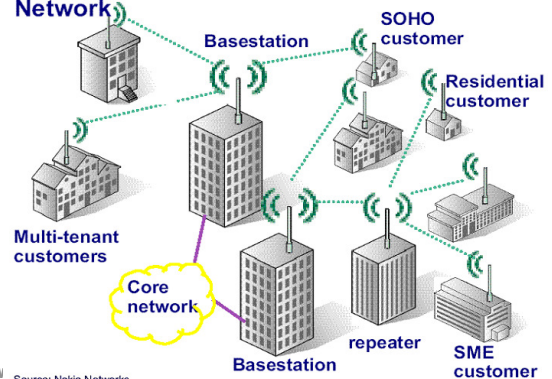

W Source: Nokia Networks

## Modulation Types

CS/E

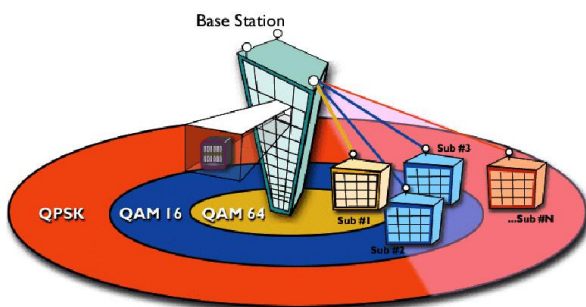

Wireless & Multimedia Network Laboratory™

Wireless  
Multimedia

## MAC Layer

CS/E

- ◆ MAC is comprised of 3 sublayers
  - Service Specific Convergence Sublayer
  - MAC Common Part Sublayer
  - Privacy Sublayer

Wireless & Multimedia Network Laboratory™

Wireless  
Multimedia

## Service Specific Convergence Sublayer

CS/E

- ◆ Classing SDUs and associate them to the proper MAC service flow and CID
- ◆ Support various protocols
- ◆ Internal format of CS payload is unique to the CS

Wireless & Multimedia Network Laboratory™

Wireless  
Multimedia

## MAC Common Part Sublayer

CS/E

- ◆ Provides the core MAC functionality
  - Bandwidth allocation
  - Connection establishment
  - Connection maintenance
- ◆ During initialization of an SS, 3 particular connections are established in both direction
  - Basic connection: short time critical
  - Primary management connection: longer more delay
  - Second management connection: higher layer management and SS configuration data

Wireless & Multimedia Network Laboratory™

Wireless  
Multimedia

## MAC PDU Formats



- Two header formats are defined
  - Generic header
  - Bandwidth request header
- Three types of MAC subheader
  - The grant management: used by an SS to convey bandwidth management
  - The fragmentation: indicate the presence and orientation in the payload of any fragmentation of SDUs
  - The packing: indicate the packing of multiple SDUs into a single PDU



## Transmission of MAC PDUs

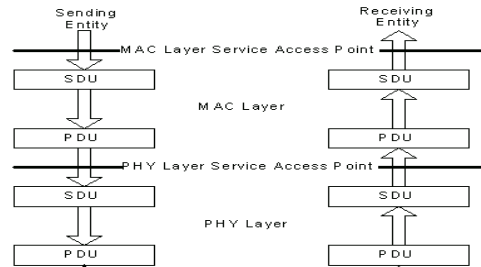

## 4 types of Scheduling Service



- Unsolicited Grant Service (UGS)
  - Real-time, periodic fixed size packets (e.g. T1 or VoIP)
  - Restrictions on bw requests (Poll-Me bit)
  - Slip Indicator (SI)
- Real-Time Polling Service (rtPS)
  - Real-time, periodic variable sizes packets (e.g. MPEG)
  - BS issues periodic unicast polls.
  - Cannot use contention requests, but piggybacking is ok.
- Non-Real-Time Polling Service (nrtPS)
  - Variable sized packets with loose delay requirements (e.g. FTP)
  - BS issues unicast polls regularly (not necessarily periodic).
  - Can also use contention requests and piggybacking.
- Best Effort Service
  - Never polled individually
  - Can use contention requests and piggybacking

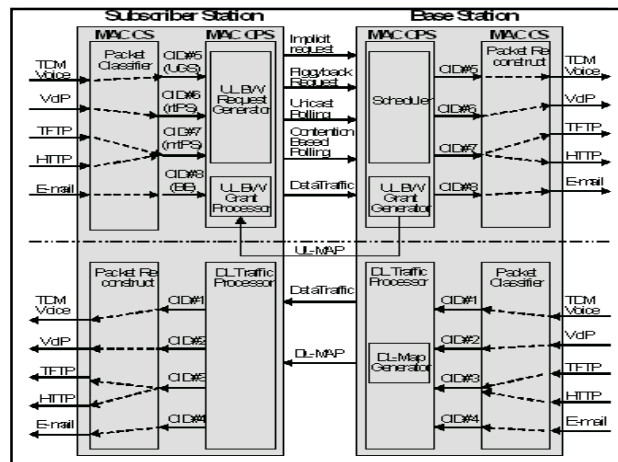

## Physical Layer



- "Burst single-carrier" modulation
- Allows use of directional antennas
- Allows use of two different duplexing schemes:
  - Frequency Division Duplexing (FDD)
  - Time Division Duplexing (TDD)
- Support for both full and half duplex stations



- Adaptive Data Burst Profiles
  - Transmission parameters (e.g. modulation and FEC settings) can be modified on a frame-by-frame basis for each SS.
  - Profiles are identified by "Interval Usage Code" (DIUC and UIUC)



**CS/E**

- ◆ Connection oriented
  - Connection ID (CID), Service Flows(SF)
- ◆ Channel access
  - UL-MAP
    - Defines uplink channel access
    - Defines uplink data burst profiles
  - DL-MAP
    - Defines downlink data burst profiles
  - UL-MAP and DL-MAP are both transmitted in the beginning of each downlink subframe (FDD and TDD).

Wireless & Multimedia Network Laboratory™

**Wireless Multimedia**

### TDD Downlink subframe

**CS/E**

Wireless & Multimedia Network Laboratory™

**Wireless Multimedia**

### FDD Downlink subframe

**CS/E**

Wireless & Multimedia Network Laboratory™

**Wireless Multimedia**

### FDD burst framing

**CS/E**

Broadcast
  Half Duplex Terminal #1  
 Full Duplex Capable User
  Half Duplex Terminal #2

Wireless & Multimedia Network Laboratory™

**Wireless Multimedia**

### Uplink subframe(TDD or FDD)

**CS/E**

Wireless & Multimedia Network Laboratory™

**Wireless Multimedia**

Round-trip delay +  $T_{proc}$

Wireless & Multimedia Network Laboratory™

**Wireless Multimedia**

## Uplink periods



- ◆ Initial Maintenance opportunities
  - Ranging
  - To determine network delay and to request power or profile changes.
  - Collisions may occur in this interval
- ◆ Request opportunities
  - SSs request bandwidth in response to polling from BS.
  - Collisions may occur in this interval aswell.
- ◆ Data grants period
  - SSs transmit data bursts in the intervals granted by the BS.
  - Transition gaps between data intervals for synchronization purposes.

## Bandwidth request and allocation



- ◆ SSs may request bw in 3 ways:
  - Use the "contention request opportunities" interval upon being polled by the BS (multicast or broadcast poll).
  - Send a standalone MAC message called "BW request" in an already granted slot.
  - Piggyback a BW request message on a data packet.

## Bandwidth request and allocation



- ◆ BS grants/allocates bandwidth in one of two modes:
  - Grant Per Subscriber Station (GPSS)
  - Grant Per Connection (GPC)
- ◆ Decision based on requested bw and QoS requirements vs available resources.
- ◆ Grants are realized through the UL-MAP.

## Unicast Polling

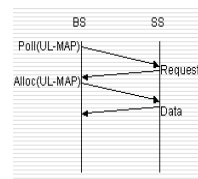

1. BS allocates space for the SS in the uplink subframe.
2. SS uses the allocated space to send a bw request.
3. BS allocates the requested space for the SS (if available).
4. SS uses allocated space to send data.

## Topic II

### UWB: Next Generation Technology for Wireless Personal Area Network



Professor Eric Hsiauquang Wu  
2007



## Outline



- ◆ What is UWB?
- ◆ Applications and Market
- ◆ Overview of IEEE 802.15.3 MAC

### Definition of FCC

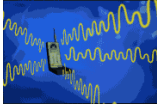
$$\text{fractional bandwidth} = \frac{2(f_H - f_L)}{f_H + f_L} > 0.25$$





Wireless & Multimedia Network Laboratory™

### UWB vs. Narrow Band

Ultrawideband Communication

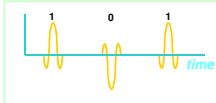
Time-domain behavior



Frequency-domain behavior

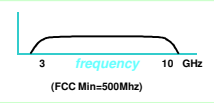

---

Narrowband Communication

Frequency Modulation

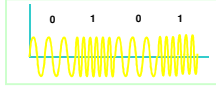

Frequency-domain behavior

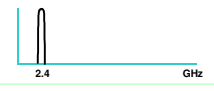

Wireless & Multimedia Network Laboratory™

### UWB Spectrum

♦ FCC ruling permits UWB spectrum overlay

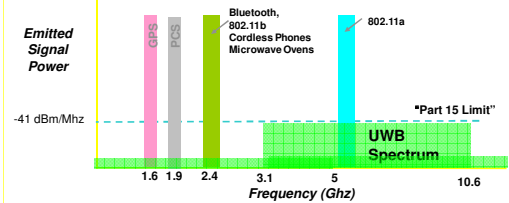

Wireless & Multimedia Network Laboratory™

### Advantages: Multi-path Immunity

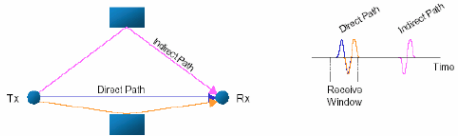

Wireless & Multimedia Network Laboratory™

### What is Piconet?

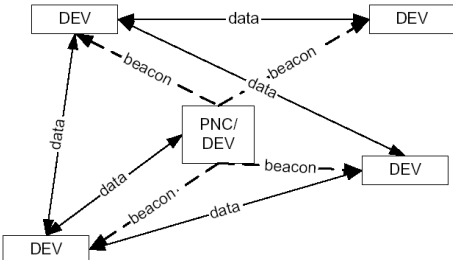

Wireless & Multimedia Network Laboratory™

### Detail Describe for MAC (Piconet Superframe)

Superframe #m-1		Superframe #m				Superframe #m+1	
Beacon #m	Contention Access Period	Contention Free Period					
		MTS 1	MTS 2	GTS 1	GTS 2	...	GTS n-1

Wireless & Multimedia Network Laboratory™

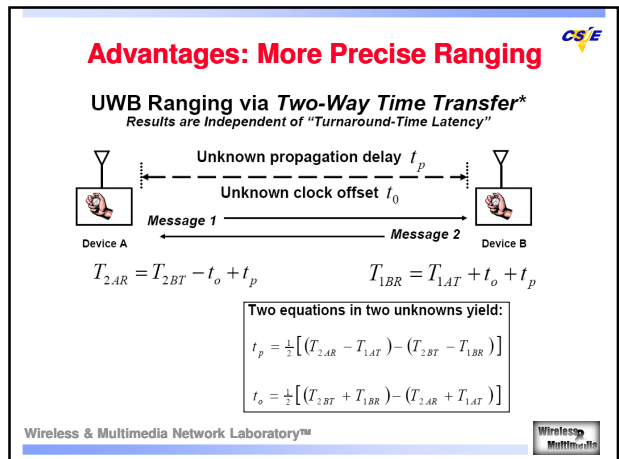
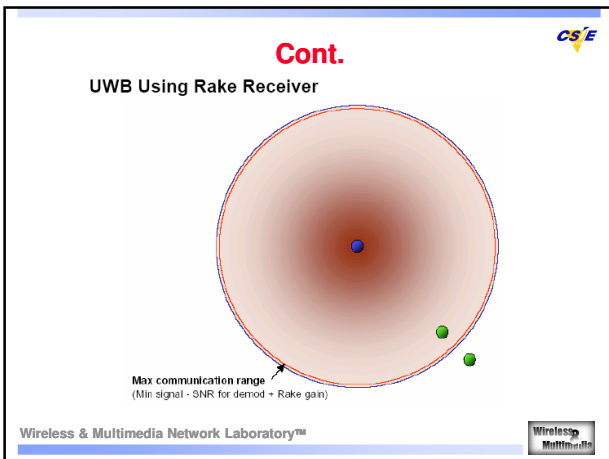
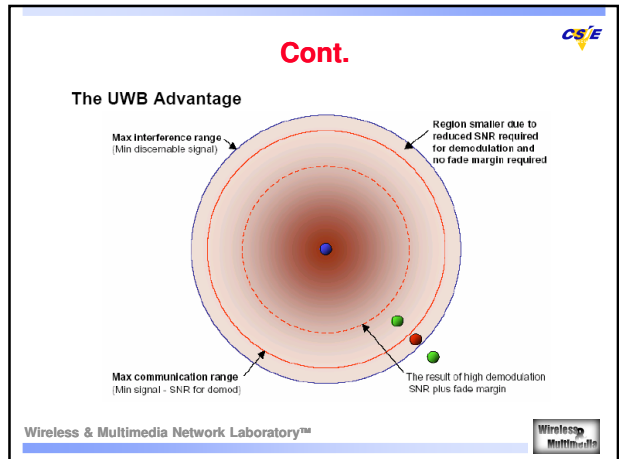
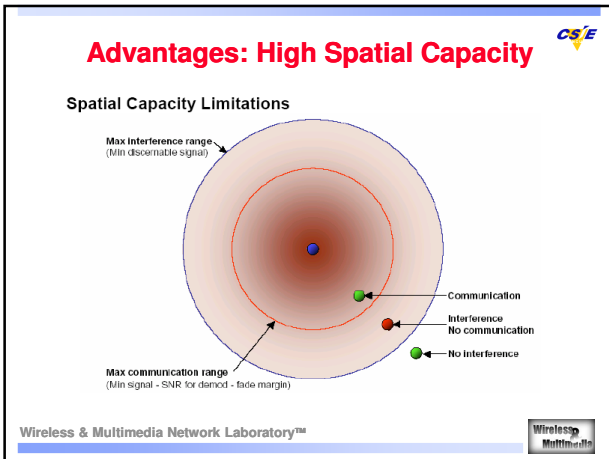
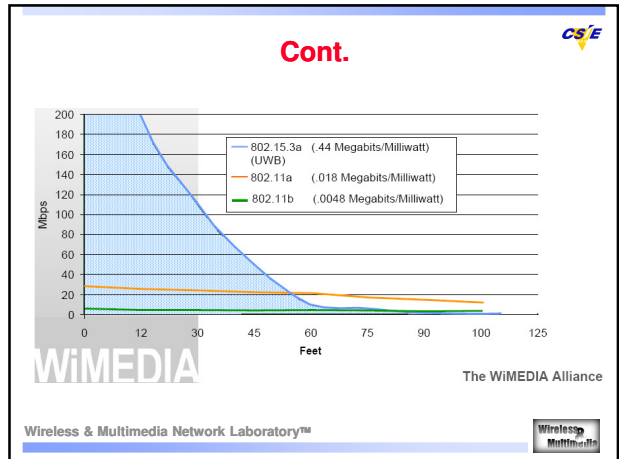
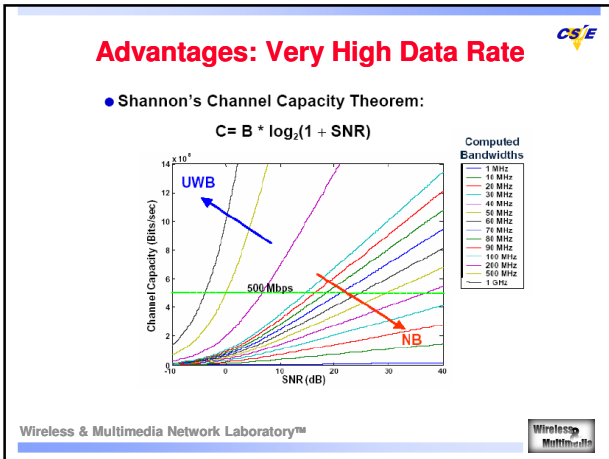



## Product

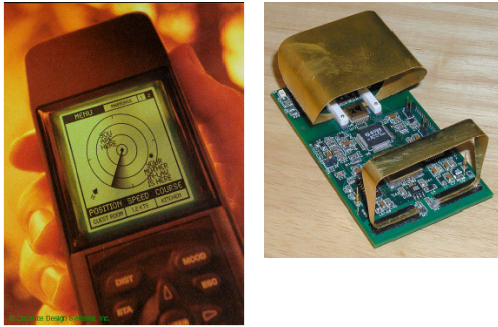

Wireless & Multimedia Network Laboratory™



## IEEE 802.15.3a Debate



- ◆ Sept. 2003 – IEEE conference results in 60% approval for OFDM
- ◆ TI/Intel (MB-OFDM) vs. Motorola/XtremeSpectrum (DS-SS)
- ◆ 75% needed for acceptance
- ◆ Compatibility issues

Wireless & Multimedia Network Laboratory™



## Applications and Market



Wireless & Multimedia Network Laboratory™



## Applications



- ◆ Positioning, Geolocation, Localization
- ◆ Communications
- ◆ Radar/Sensor

Wireless & Multimedia Network Laboratory™



## INTEL: Wireless USB (Home)

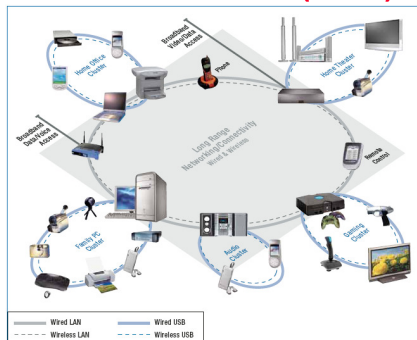

Wireless & Multimedia Network Laboratory™



## Office

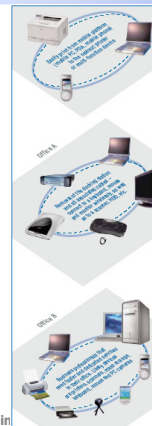

### Some Top Candidates for Wireless USB Devices in the Office:

- Digital Projector
- Headset and Speakers
- Mass Storage (HDD, DVD-RW, CD-RW, etc.)
- Mobile Phone
- PC Camera
- PDA
- Printer
- Scanner

Wireless & Multimedia Network Laboratory™



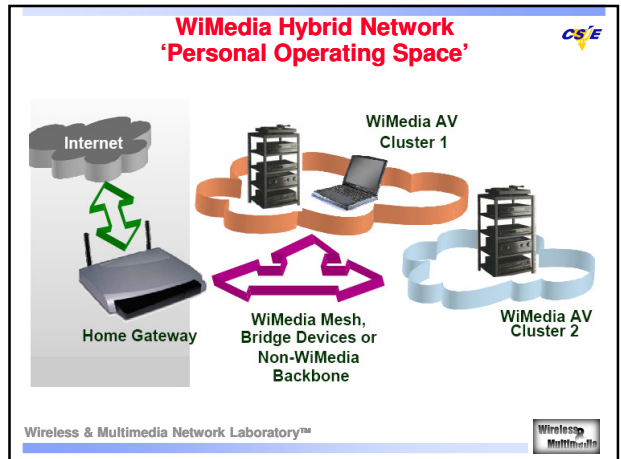
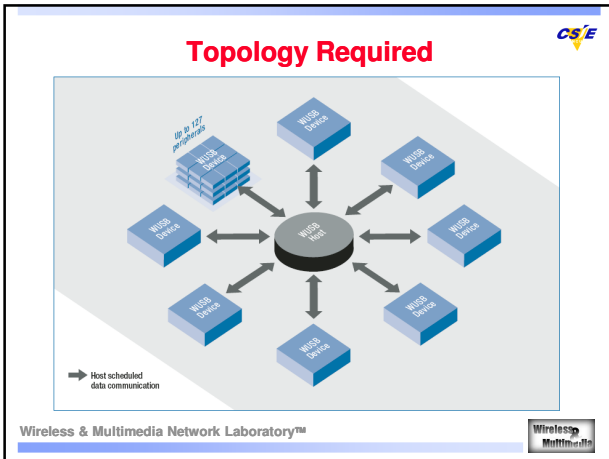

## IEEE 802.15.3 MAC

Wireless & Multimedia Network Laboratory™

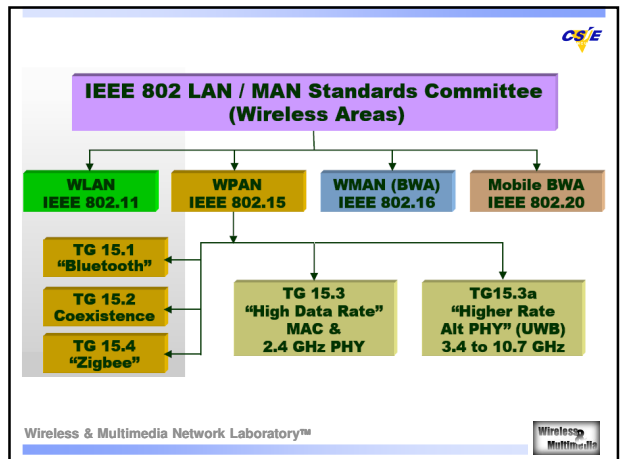

## WPAN



- ◆ **Wireless Personal Area Network**
  - A wireless personal area network (WPAN) is a wireless ad hoc data communications system which allows a number of independent data devices to communicate with each other. A WPAN is distinguished from other types of data networks in that communications are normally confined to a person or object that typically covers at least 10 meters in all directions and envelops the person or a thing whether stationary or in motion.
- ◆ **Piconet**
  - A set of devices within a personal operation space operating under the control of a piconet controller (PNC) in order to share a wireless resource. The PNC always provides the basic timing for the WPAN. Additionally the PNC manages the quality of service (QoS) requirements of the WPAN.

Wireless & Multimedia Network Laboratory™



## WPAN Topology

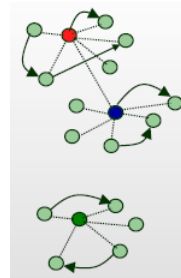

- Parent Piconet Controller
- Piconet Device
- Child/Neighbor Piconet Controller
- Piconet Relationship
- Peer to Peer Data Transmission
- Independent Piconet Controller

Wireless & Multimedia Network Laboratory™



## Piconet Superframe

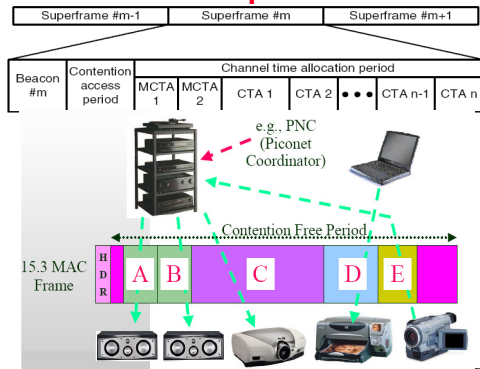

Wireless & Multimedia Network Laboratory™



## Main Characteristics



- ◆ **High Rate WPAN:**
  - Short Range (at least 10m)
  - High Data rates
    - ◆ 15.3 PHY 20-55 Mbps
    - ◆ 15.3a PHY 110-480 Mbps
- ◆ **Dynamic Topology:**
  - Mobile devices often join and leave piconet
  - Short time to connect (<1s)
- ◆ **Ad-hoc network with Multimedia QoS provisions**
  - TDMA for streams with time based allocations
  - Peer to peer connectivity
- ◆ **Multiple Power Management Modes:**
  - Designed to support low power portable devices

Wireless & Multimedia Network Laboratory™



## Cont.



- ◆ **Low price point, low complexity and small form factor**
  - Embedded in mobile device
  - USB/1394 Dongle
- ◆ **Secure Network:**
  - Authentication using higher layer protocol (PK or other)
  - Dynamic key distribution
  - Shared Key encryption (AES 128) and integrity (data and commands) - CCM
- ◆ **Ease-of-use:**
  - Dynamic coordinator selection and handover
  - Does not rely on a backbone network

Wireless & Multimedia Network Laboratory™



## Starting Piconets - Scan

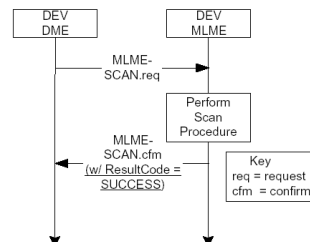

- Open scan
- Non-open scan

Wireless & Multimedia Network Laboratory™



## Detect Another Piconet

- Changing to a different channel.
- Become a child or neighbor piconet of the other piconet.
- Reduce the piconet's transmit power.

## Starting a Piconet

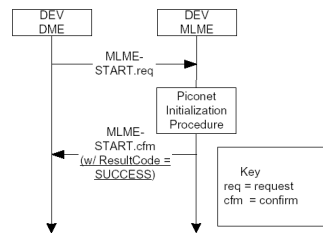

- MLME-START.request shall only to start its own piconet and shall not attempt to associate with an existing piconet.
- The DEV should choose the channel with the least amount of interference to start the piconet.

## PNC Handover

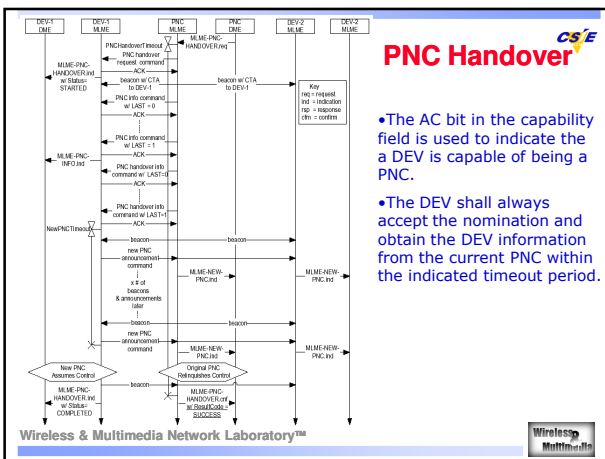

- The AC bit in the capability field is used to indicate the a DEV is capable of being a PNC.
- The DEV shall always accept the nomination and obtain the DEV information from the current PNC within the indicated timeout period.

## Comparison Order

Order	Information	Note
1	PNC Des-mode bit in capability field	PNC Des-mode=1 is preferred
2	SEC bit in capability field	SEC=1 is preferred
3	PSRC bit in capability field	PSRC=1 is preferred
4	PSAVE bit in capability field	PSAVE=1 is preferred
5	Max number GTS	Higher value is preferred
6	Transmitter power level (PHY dependent)	Higher value is preferred
7	MAX PHY rate (PHY dependent)	Higher value is preferred
8	DEV address	Higher value is preferred

## Child Piconet

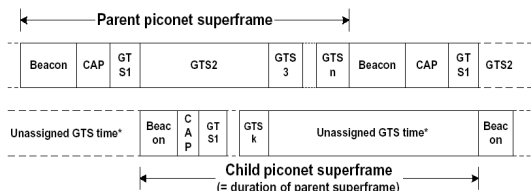

\* The unassigned GTS slot time of the child piconet that is in the parent piconet's contention free period, may be used for establishing shared GTS slots for internetwork communication.

## Process for Creating a Child Piconet

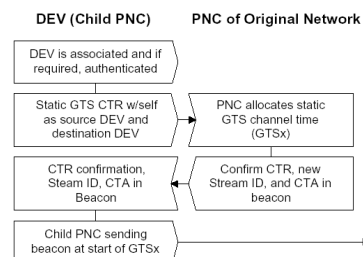

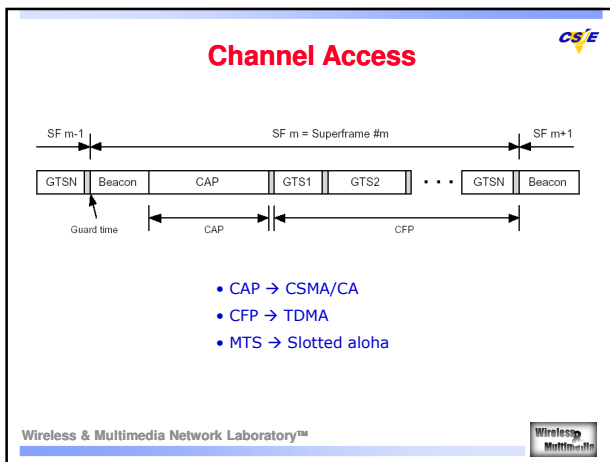
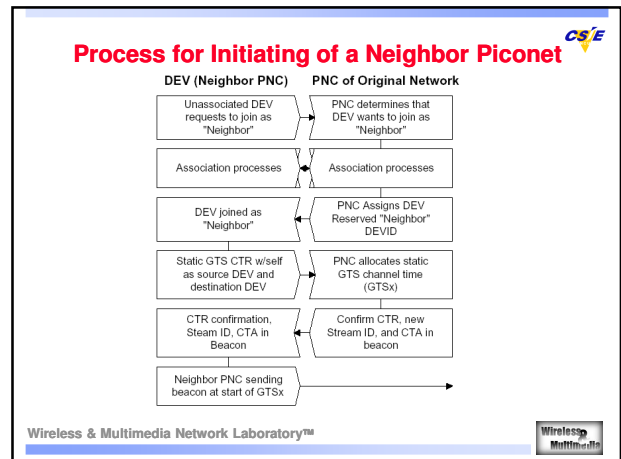
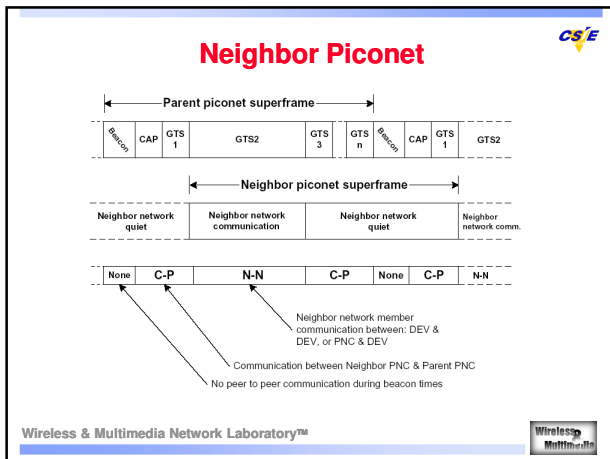

- ### Guaranteed Time Slots (GTS)
- Dynamic GTS
    - The PNC moves a dynamic GTS by simply changing the CTA parameters in the beacon.
  - Pseudo-Static GTS
    - Allocated only for stream connections.
    - PS-GTS may be moved within the CFP by the PNC, but the PNC needs to notify the affected DEVs by sending the probe command, with the new CTA.
  - The algorithm used to allocate the channel time and assign GTSs is outside of the scope of this standard.
- Wireless & Multimedia Network Laboratory™

- ### Management Time Slots (MTS)
- MTS is identical to GTS except that the PNC address is either the SrcID or the DestID in the CTA.
  - Open MTS.
    - For command frame.
  - Association MTS.
    - Support fast connections.
- Wireless & Multimedia Network Laboratory™

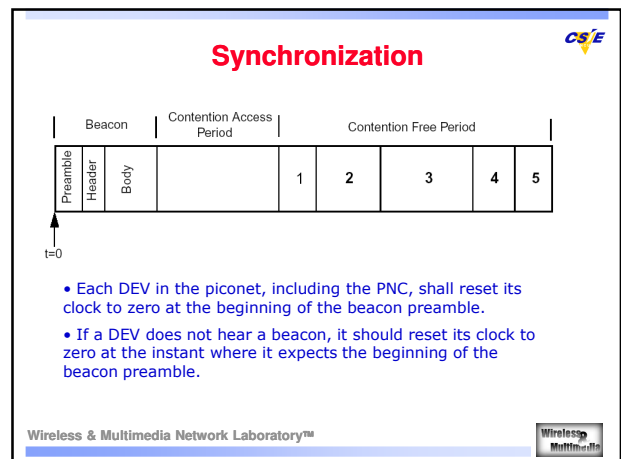

## Scalable Security Capabilities



Capability	Mode 0 <sup>(1)</sup>	Mode 1	Mode 2
Cryptographic mutual authentication <sup>(2)</sup>		X [ECMQV NTRUEncrypt RSA]	X [ECMQV RSA]
Data/Command integrity & auth. <sup>(2)</sup>		X	X
Data privacy <sup>(2)</sup>		X	X
Digital certificates <sup>(3)</sup>			X

- PK Authentication: ECMQV 283-koblitz, NTRUEncrypt 251, RSA-OAEP 1024
- <sup>(1)</sup> Mode 0 (no security) is mandatory. All other modes are optional
- <sup>(2)</sup> Shared key encryption and data authentication and integrity using AES-CCM
- <sup>(3)</sup> X.509 certificates for Mode2 (RSA & ECQMV) or implicit certificates (ECQMV) requiring interaction w/ an external trusted party



The WiMedia Alliance

Wireless & Multimedia Network Laboratory™

