

# 無線網路多媒體系統 Wireless Multimedia System

Lecture 7: Network Mobility  
吳曉光博士  
<http://inrg.csie.ntu.edu.tw/wms>



## Agenda

- ◆ All-IP System: Beyond 3G
- ◆ Evolutions of PCS
- ◆ ALL IP Challenges
  - Mobile IP/Cellular IP
  - QoS Provisions: Integrated Service / DiffServ
- ◆ Next Week (Wireless TCP)



## Reading

- ◆ [Bhagwat96] Pravin Bhagwat, Charles Perkins, and Satish Tripathi, "Network Layer Layer Mobility: An Architecture and Survey"

Foreign Agent Tables

Visitor Table		
Host	HA	Timestamp

Home Agent Tables

Away Table		
Host	FA	Timestamp

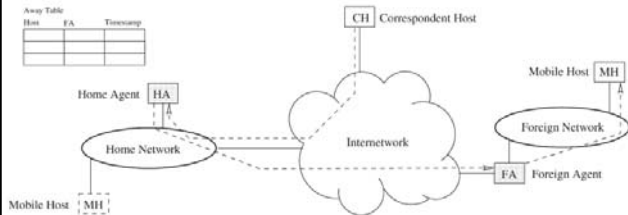

## ALL IP



Something to happen?

## MT Scheduler

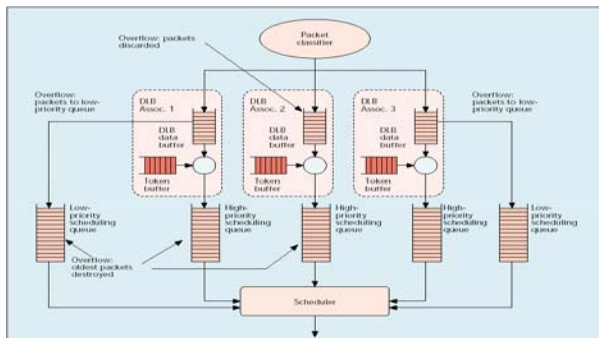

## A IP reference Architecture for Wireless Mobile System

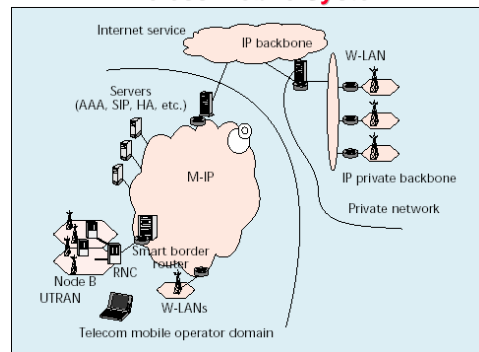

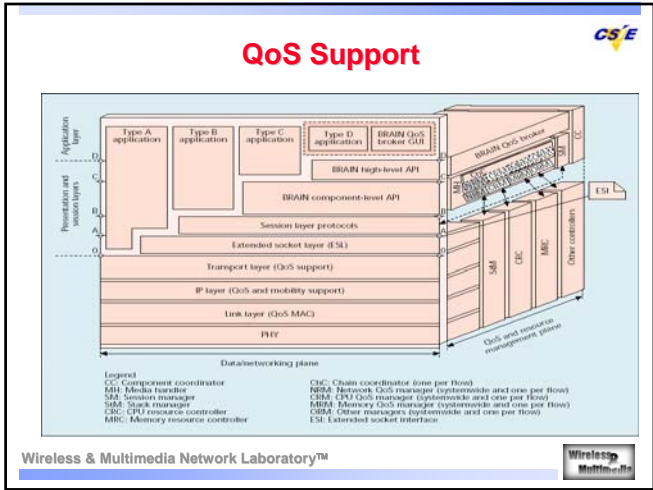
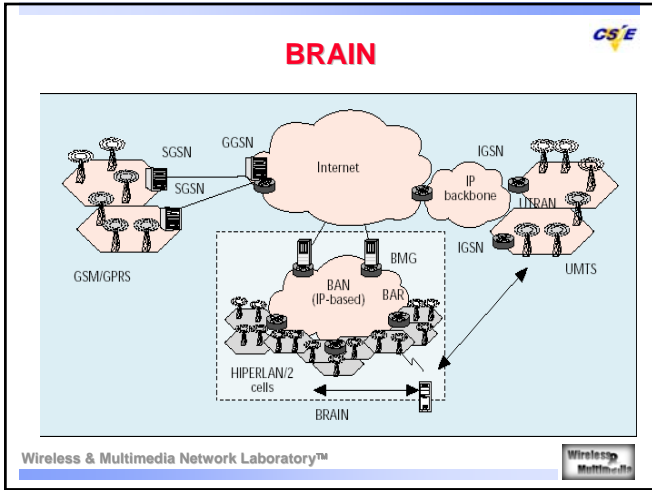
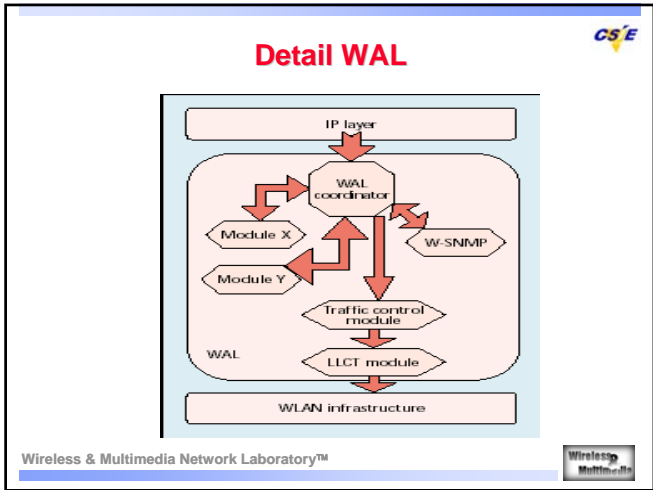
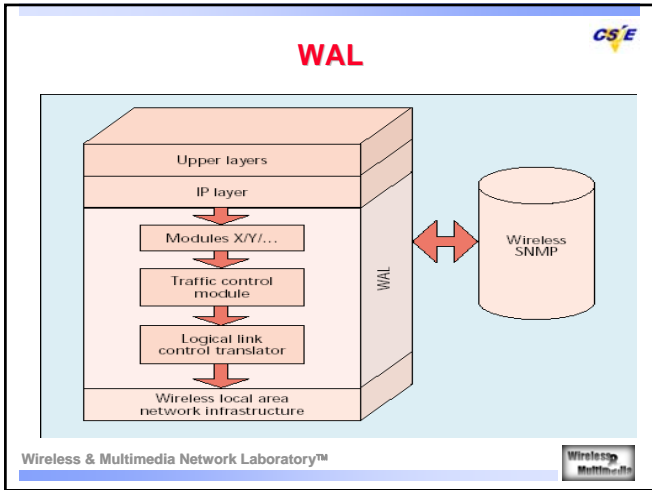
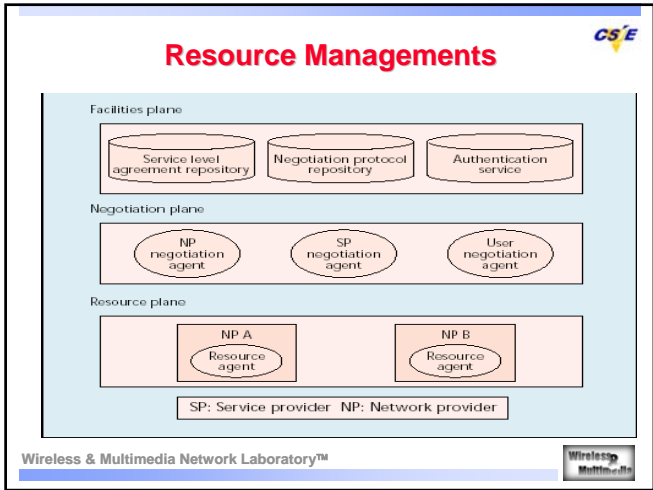
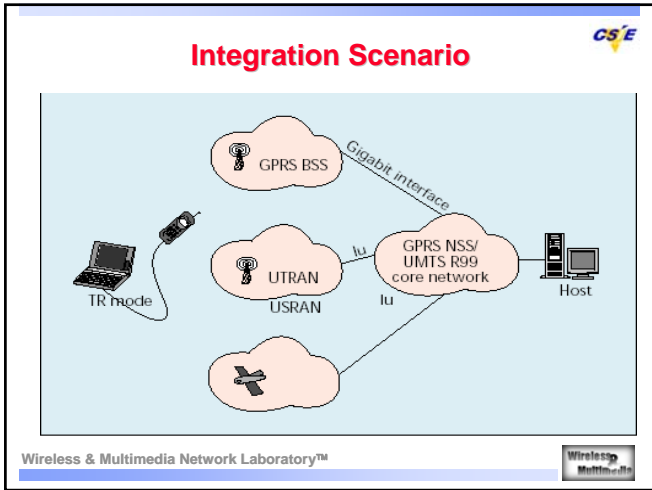

## IP QoS Modeling

Wireless & Multimedia Network Laboratory™

## A mobile network in a B3G system

Wireless & Multimedia Network Laboratory™

## Mobile network scenarios

Wireless & Multimedia Network Laboratory™

## Traffic flows with basic network mobility

Wireless & Multimedia Network Laboratory™

## Lecture Outline

- ◆ Mobility in wireless LANs
- ◆ Problems in making Internet mobile
- ◆ Canonical packet forwarding architecture for Mobile-IP
- ◆ Columbia's Mobile-IP schema

Wireless & Multimedia Network Laboratory™

## Making the Internet Mobile

- ◆ Goal
  - Provide *continuous* IP connectivity to "mobile" users.
- ◆ Mobility == change in how MH accesses the internet
  - Physically move so that access to internet is via a different basestation.
  - Switch network interfaces
- ◆ Continuous connectivity
  - Datagrams for MH must be delivered to its current location
  - Mobility must be transparent to applications
    - ◆ Applications must not die or need to restarted
    - ◆ Performance transparency also desirable
- ◆ Desirable
  - Secure
  - Work across security domains
  - Require no changes to existing stationary hosts

Wireless & Multimedia Network Laboratory™

## Mobility in Wireless LANs: Basestation as Bridges

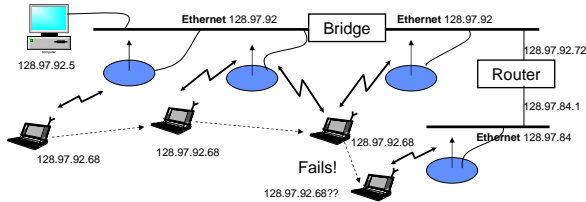

- Basestations are bridges(layer 2) – i.e. they relay MAC frames
  - Smart bridges avoid wasted bandwidth
- Works the within an ethernet(or other broadcast LAN)
  - Fails across network boundaries, and in switched LANs(e.g. ATM)

Wireless & Multimedia Network Laboratory™



## Internet Naming and Addressing

- Collection of networks that are connected by routers
- Each internet host(each network interface) has two identifiers:
  - Internet (IP) Address(32-bit)
  - Host Name (string)
    - Domain Name System (DNS) maps host names to IP address
- Applications refer to hosts by names
  - Use Domain Name System (DNS) to map host names to IP addresses
    - DNS lookup done once only at connection set-up
  - Transport protocols developed that assume this static binding
    - E.g. a TCP connection is identified by
      - Source IP address, source TCP port, destination IP address, destination TCP port
- Packets carry source and destination IP addresses
  - Routers use routing tables to forward packets based on destination address
  - Packet sent directly to destination within a network (e.g. ethernet)

Wireless & Multimedia Network Laboratory™



## DNS-based Resolution

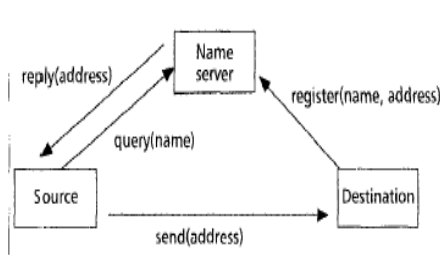

Wireless & Multimedia Network Laboratory™



## Hierarchical Addressing

- Routers maintain network topology in routing tables
  - Flat IP address space would make routing tables huge!
    - Many many millions of hosts
  - IP address space is therefore hierarchical
    - IP address is a tuple: (network id, host id)
      - e.g., consider 192.11.35.53
- | Network id |    |    | Host id |
|------------|----|----|---------|
| 192        | 11 | 35 | 53      |
- Internet routers required to maintain network topology only at the granularity of individual networks
    - Only network id part of destination address used in routing
    - Makes routing tables manageable

Wireless & Multimedia Network Laboratory™



## Key Observation: IP address serves two purposes!

- Endpoint identifier for transport and application layer
    - MH's IP address must be preserved to retain transport-layer sessions
      - All TCP connections would die if MH acquires a new IP address
  - Routing directive for network layer
    - MH's IP address must be changed for hierarchical routing to work!
      - Packets will continue to get routed to the old network
      - DNS entry will also need to be changed
- What should on do?  
This is the primary problem in making Internet mobile!

Wireless & Multimedia Network Laboratory™



## "Non-solutions" to Internet Mobility

- Enhance DNS
    - Historically, DNS does not have dynamic name-address binding updates
      - Optimized for access cost
      - DNS clients cache DNS records
      - Hard to optimize for both access and update costs
    - Solves only part of the problem
      - TCP connections will still die!
  - Keep per-MH routing information at all routers
    - Completely breaks the hierarchical routing model
    - Unbounded growth in routing table sizes at all routers
  - Fix all the transport layer and higher protocols, and applications
    - Yeah, sure.....
- Clean solutions: fix the network (IP) layer!

Wireless & Multimedia Network Laboratory™



### Making IP Network Layer Mobile

CS'E

•Challenge of Mobile-IP  
**How to direct IP packets to MH that travels to a Foreign Network away from MH's Home Network?**

- MH is assigned a home address as its IP address
  - Home network is the network containing the home address
  - DNS queries for MH return the home address
- Mobile-IP only concerned with moves across networks
  - Moves within home network (e.g. ethernet) handled by link-layer bridging.

Wireless & Multimedia Network Laboratory™

### Illustration of terms

CS'E

Wireless & Multimedia Network Laboratory™

### Key to Mobile-IP Two-Tier Addressing

CS'E

- MH has two IP addresses associated with it
  - Does not mean two IP address are assigned!
- First component of the address serves as the routing directive
  - Reflects MH's point of attachment to Internet
    - Derived from the foreign network
  - Changes whenever MH moves to a new network
  - Internet routers use this address to route to MH's point of attachment
- Second component of the address serves as the end-point identifier
  - This is the home address
  - Remains static throughout the lifetime of MH
  - Only this address used for protocol processing above network layer
    - MH remains virtually connected to the home network
- Two-tier addressing is only a logical concept
  - IP packet headers can't actually carry two addresses!
- MH to Stationary Host (SH) packets do not need special handling

Wireless & Multimedia Network Laboratory™

### Two-Tier Addressing for Mobile Hosts

CS'E

Wireless & Multimedia Network Laboratory™

### Typical Example

CS'E

	Forwarding address				Home address			
MH	128	8	128	Y	128	8	16	Z

MH: Mobile host  
S: Stationary host

Wireless & Multimedia Network Laboratory™

### Packet Forwarding model

CS'E

$f$  : Home address  $\rightarrow$  Forwarding address  
 $g$  : Forwarding address  $\rightarrow$  Home address

Wireless & Multimedia Network Laboratory™

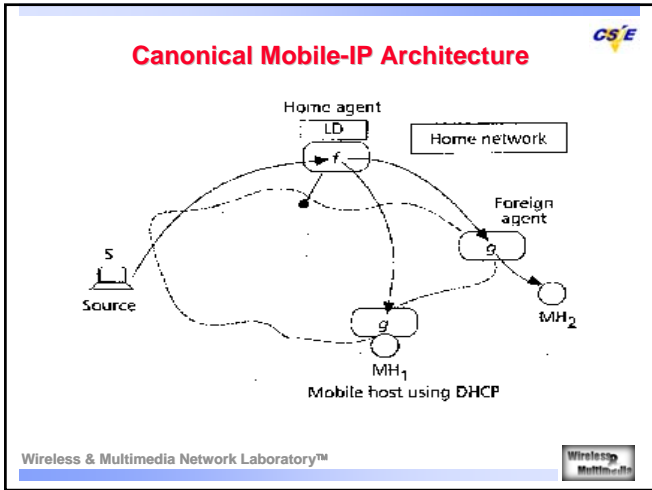

- ### Components of Canonical Mobile-IP Architecture
- ◆ Forwarding Agent (FA)
    - Forwarding component of two-tier address is the address of FA entity
    - FA receives packets on behalf of MH
      - ◆ Packets contain FA's address as destination
    - FA maps forwarding address to MH's home address
      - ◆ FA:  $g(\text{forwarding address}) \rightarrow \text{home address}$
    - FA then relays the packet to MH
    - FA represents a function, not a machine
  - Issues:
    - Where can FA be located?
      - ◆ MH, BS, somewhere else
    - How does MH find the FA in a foreign network? (and, vice versa)
      - ◆ Route advertisement and registration protocol
      - ◆ FA periodically advertises its presence (beacons)

- ### Component of Canonical Mobile-IP Architecture (contd.)
- ◆ Location Directory (LD)
    - Records association between home and forwarding addresses
      - ◆ Contains most up to date mapping of MH to its FA
    - MH sends updates to LD on moving
    - Issues:
      - Centralized vs. distributed realization
        - ◆ Centralized is infeasible – too many MHs in the Internet
      - How to distribute?
        - ◆ Cost operation
        - ◆ Security
        - ◆ Ease of location
        - ◆ Ownership
    - Possible distribution policy: *owner-maintains*
      - ◆ Some agent in home network maintains LD information for a MH responsible for security, authentication, updates, and distribution
      - ◆ a CH does not need to find the right LD component to query router in home network can forward to the correct LD component

- ### Component of Canonical Mobile-IP Architecture (contd.)
- ◆ Address Translation Agent (ATA)
    - CH sends packets to MH at its home address
    - ATA replaces MH's home address with FA's address in packets
      - ◆  $ATA: f(\text{home address}) \rightarrow \text{forwarding address}$
    - address translation involves:
      - ◆ Querying the LD
      - ◆ Obtain address of the FA corresponding to the MH
      - ◆ Use FA's address to forward packet to MH's location
    - Issues:
      - ◆ Where to locate ATA
        - At CH: but will need to change software in millions of hosts! elsewhere
      - ◆ Querying LD for every packet is expensive: cache LD entries?
        - Improves performance
        - but, requires maintaining consistency between LD and cached entries!

- ### Location Update Protocol (LUP)
- ◆ LUP is the reliable mechanism for
    - Keeping LD up to date
    - Keeping cached LD entries consistent with master LD
  - ◆ Choice of LUP depends on caching policy
    - Together they determine scalability and routing characteristics
  - ◆ What if no LD caching
    - ATA must be collocated with LD to avoid per-packet queries
    - Packets from CH will first travel to home network before being sent to FA no optimal paths!
  - ◆ What if there is caching?
    - Routing efficiency is improved no more travel to home network
    - but, vulnerable to security attacks cache updates must be authenticated otherwise, traffic to MH may be redirected away!

- ### Address Translation Mechanisms
- ◆ Encapsulation approach (IP-in-IP tunnel)
    - ATA appends new header at the beginning of datagram
    - Outer header contains the forwarding address
    - Inner header contains the home address
    - Internet routes according to outer header
    - FA strips the outer header and delivers datagram locally to MH
-

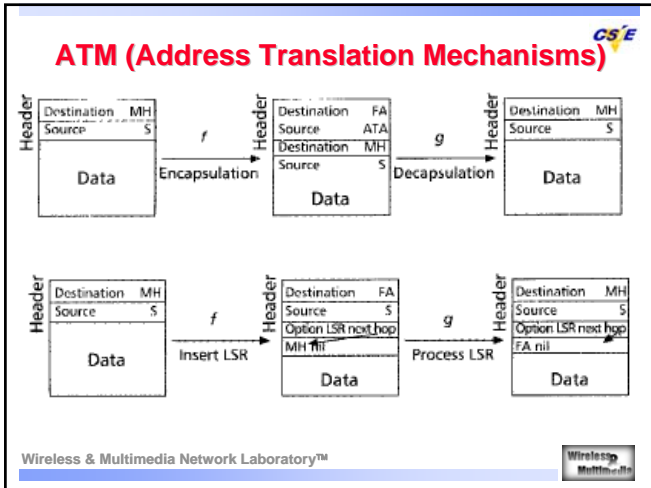

- ### Address Translation Mechanisms (contd.) CS'E
- ◆ Loose Source Routing approach
    - Option in IP packets to specify a sequence of IP addresses to follow path is automatically recorded in the packet destination can send reply back along reverse path
    - ATA can use LSR to cause packets to MH to be routed via FA co-locate ATA at CH, and FA at MH
      - ◆ MH sends to CH using LSR, ATA/CH reverses the path
- Wireless & Multimedia Network Laboratory™ Wireless Multimedia

- ### Various Mobile-IP Proposals CS'E
- ◆ Many Mobile-IP systems have been proposed (and some implemented)
    - Columbia's Mobile-IP
    - Sony's Virtual (VIP)
    - IBM's LSR Scheme
    - Stanford's MosquitoNet Scheme
    - IMHP (Internet Mobile Host protocol)
    - IETF's Mobile-IP for IPv4
    - IETF's Mobile-IP for IPv6
    - etc.
  - ◆ All are special cases of the canonical mobile-IP architecture
    - Make different choices of
      - ◆ FA location
      - ◆ ATA location
      - ◆ Choice of LUP address translation mechanism
- Wireless & Multimedia Network Laboratory™ Wireless Multimedia

- ### Example: Columbia's Mobile IP CS'E
- ◆ Campus environment with a reserved subnet for MHs
    - MHs home address are from the reserved subnet
  - ◆ Group of cooperating Mobile Support Routers (MSR)
    - MSR advertises reachability to wireless subnet via beacons
    - MHs connect to campus backbone through MSR
    - MSR forwards traffic to/from MHs
  - ◆ On moving, MH registers with the new MSR
    - New location is provided to the previous MSR
  - ◆ CH sends packet to MSR closest to CH
    - This MSR either delivers the packet or forwards it to the right MSR after encapsulation
    - Right MSR is located by a multicast WHO\_HAS query to other MSRs
  - ◆ Wide area operation uses a pop-up mode
    - A temporary address is used by MH as a forwarding address
    - MH does its own encapsulation/decapsulation
- Wireless & Multimedia Network Laboratory™ Wireless Multimedia

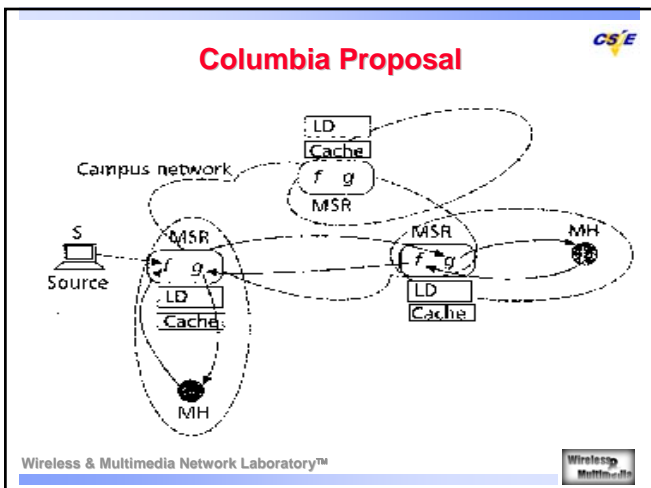

- ### Columbia's Mobile-IP Mapped to Canonical Architecture CS'E
- ◆ MSR performs both encapsulation & decapsulation
    - Both f and g are collocated at MSR
    - MSR acts as FA for MHs in its coverage area
    - MSR acts as ATA for packets addressed to other MHs
  - ◆ LD is distributed realization of the owner-maintains scheme
    - Each MSR maintains a table of MHs in its coverage
    - MSR is a distributed realization of home router
    - Tables of MHs in MSR together constitute an owner-maintained LD
  - ◆ Caching policy for LD entries is "need-to-know"
    - MSR sends WHO\_HAS query if it does not know MH's location
  - ◆ LUP is lazy-update
    - When MH moves, only primary and previous copy of LD entry is updated
    - Cached entries are assumed correct by default
    - Stale cache entry causes packet delivery failure, triggering WHO\_HAS
  - ◆ 100% backward compatible – no existing internet entities are affected
- Wireless & Multimedia Network Laboratory™ Wireless Multimedia

## Performance Characteristics of Columbia Mobile-IP

- Control
  - LD cache at ATA is updated when packet routing is needed
  - Limits control traffic
  - But, slow "first" packet due to WHO\_HAS query results in SYN packet being lost in TCP (start of transmission)
- Overhead of IP-in-IP
  - 20 bytes (4% on 500 byte packets)
- Routing
  - Requires routing to nearest MSR to be optimal
  - Not optimal for pop-up mode
- Implementation on 33 MHz 486 based MSRs
  - 1.4 ms for WHO\_HAS
  - 45 microseconds for encapsulation (per packet overhead)

Wireless & Multimedia Network Laboratory™



## Route Optimization

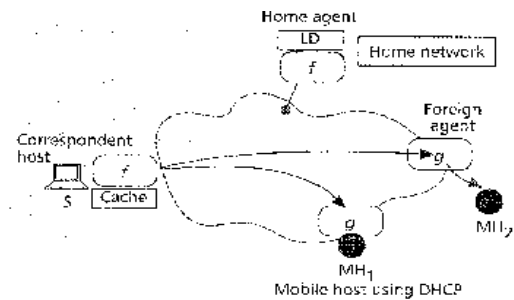

Wireless & Multimedia Network Laboratory™



## Route Optimizations



Figure 4. Behavior when CH is Close to MH



Figure 5. A Smart Correspondent Host.

Wireless & Multimedia Network Laboratory™



## Security Issues



Figure 2. Problem with Source Address Filtering

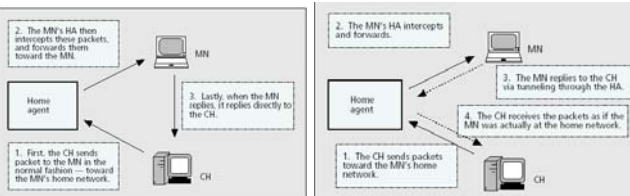

Figure 3. Bi-directional Tunneling

Wireless & Multimedia Network Laboratory™



## Tunneling



Wireless & Multimedia Network Laboratory™



## IPv6 Mobility Proposal

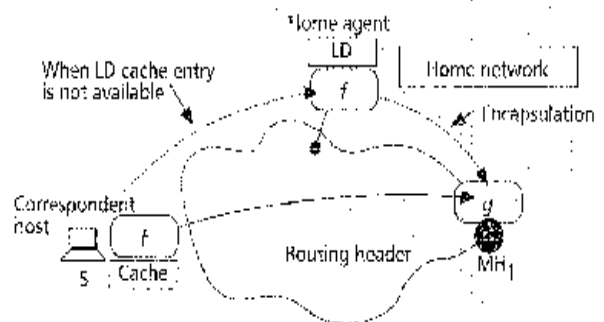

Wireless & Multimedia Network Laboratory™





### Evolutions of PCS



PCS Requirements

### PCS network architecture

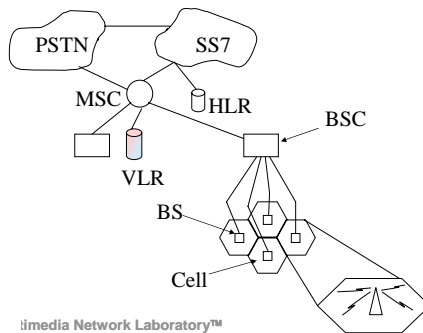

### Location Update Procedure

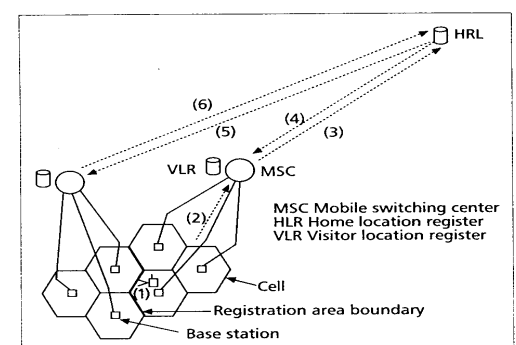
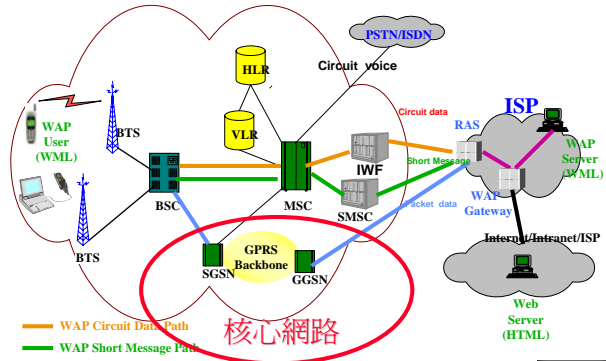
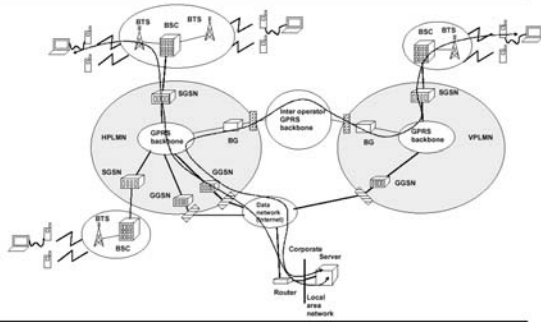

Figure 3. Location registration procedures.

### GPRS



### Data transfer MS-fixed



### Data transfer MS-MS

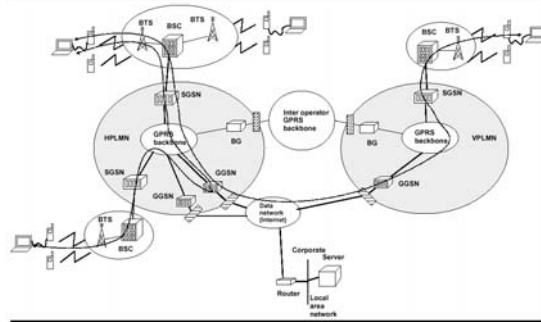

## Coming Challenges for IP



Location Managements~ handoff, roaming  
 QoS Transport~ Backbone delivery

## Mobility

- ◆ User mobility
  - Micro
  - Macro
- ◆ IP mobility support
  - Mobile IP
  - Cellular IP
  - HAWAII
  - Hierarchical Mobile IP

•Handoff issue  
 •Location management  
 •Paging

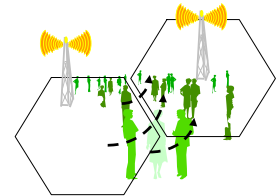

## Nomadic wireless access

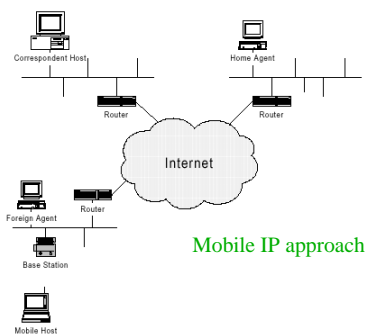

Mobile IP approach

## Cellular IP

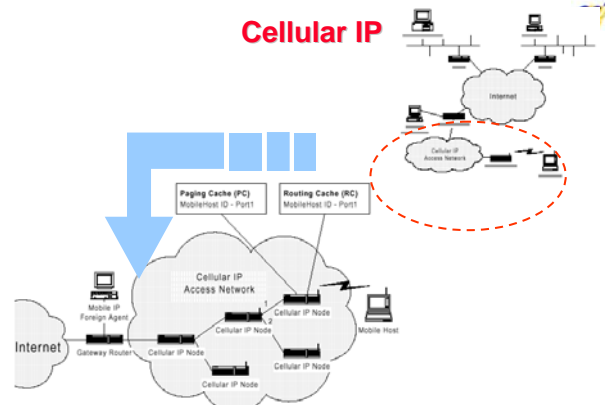

## Hierarchical Mobility Management

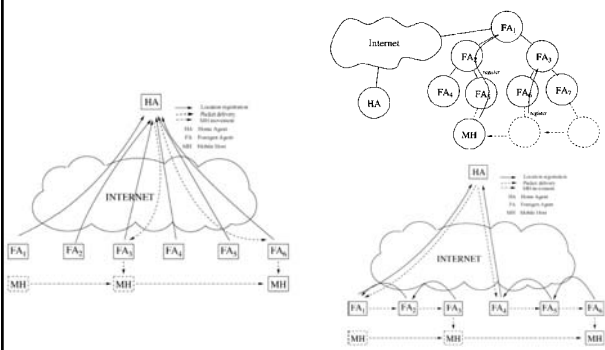

## Mobility Management

- ◆ Mobility Classification
  - Roaming
  - Macro-mobility
    - Domain mobility
  - Micro-mobility
    - Subnet mobility
- ◆ Solutions
  - Network layer solution: Mobile IP
  - Application layer solution: SIP

## Mobile IPv4: Registration Example

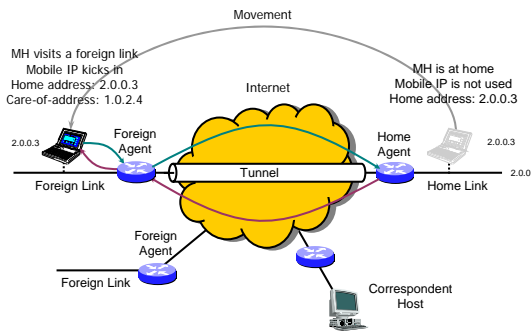

Wireless & Multimedia Network Laboratory™



## Mobile IPv4: CH-to-MH Routing Example

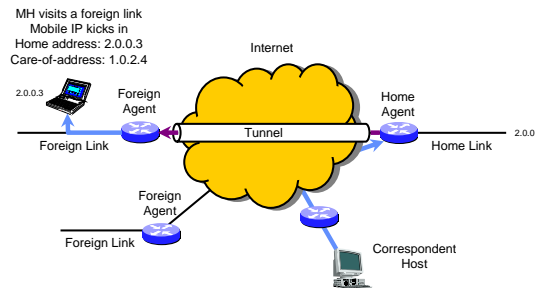

Wireless & Multimedia Network Laboratory™



## Mobile IPv4: MH-to-CH Routing Example

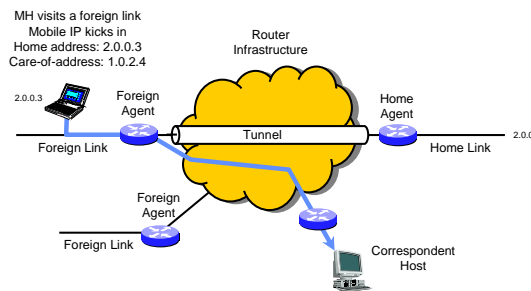

Wireless & Multimedia Network Laboratory™



## Mobile IPv4

- ◆ Triangle route problem
- ◆ Micro-mobility improvement
  - Cellular IP, Campbell in Column University.
  - Regional Registration, Perkins, Nokia Center.
  - ...

Wireless & Multimedia Network Laboratory™



## Mobile IPv6: Binding Update

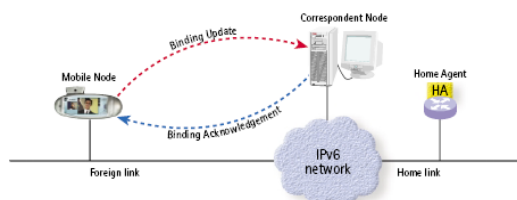

Wireless & Multimedia Network Laboratory™



## Application Layer Mobility Using SIP

- ◆ Terminal Mobility
- ◆ Session Mobility

Wireless & Multimedia Network Laboratory™



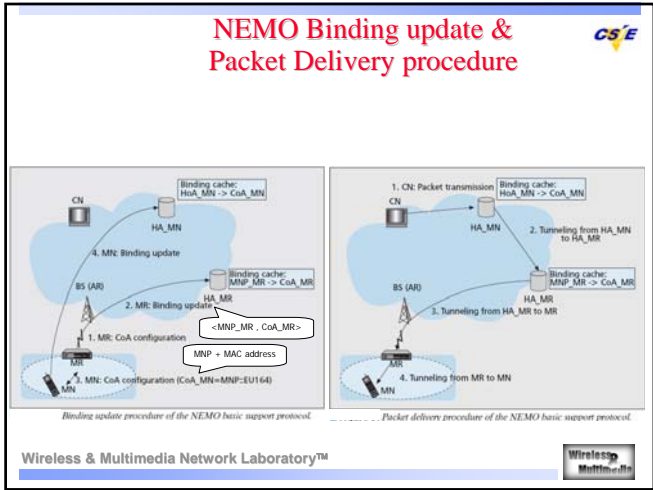
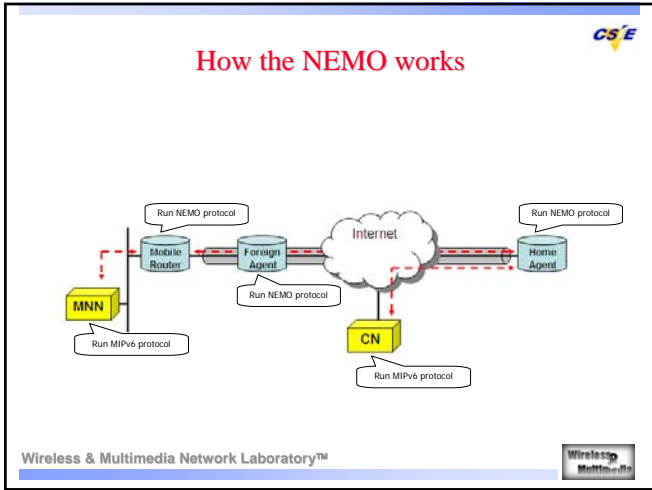
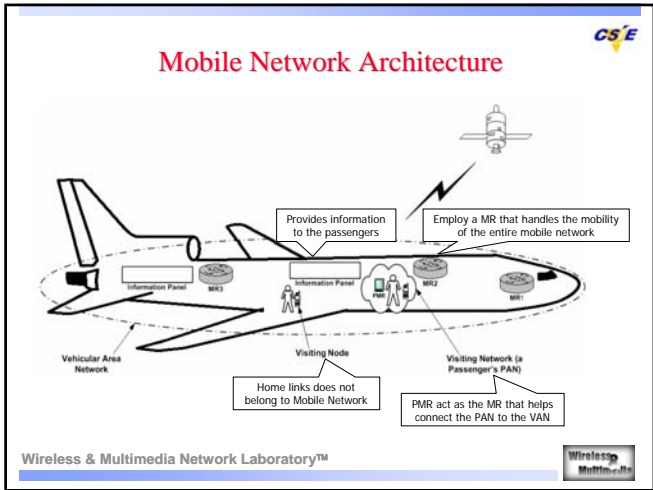
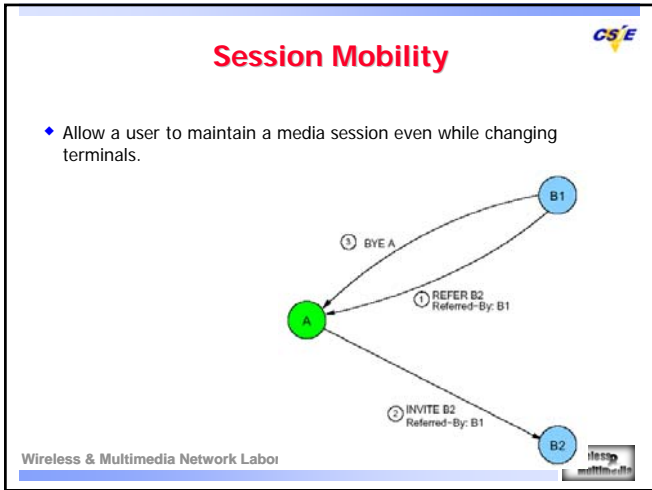
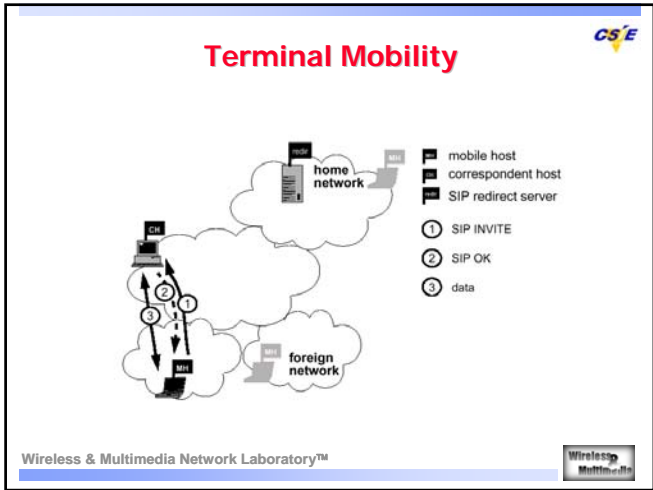
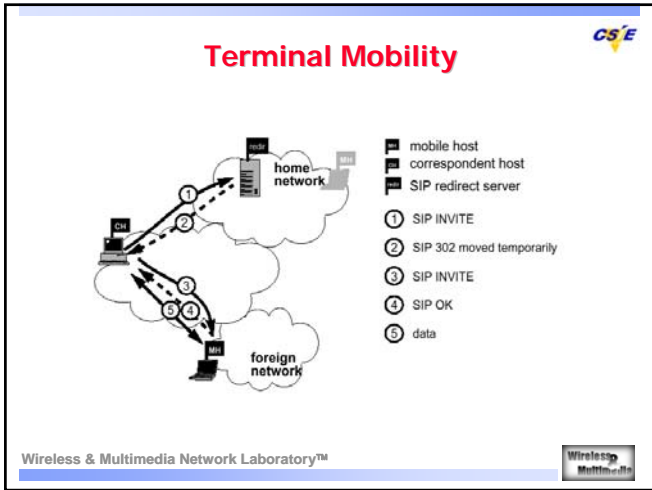

## SafeWeb

- ◆ A big proxy
- ◆ Reassembly HTML to hide user info.
- ◆ Using SSL between SafeWeb and Client

SafeWeb acts as an intermediary that routes and encrypts all data transmitted between an individual's computer and the Web sites visited.

Wireless & Multimedia Network Laboratory™

## Screenshot of SafeWeb

Wireless & Multimedia Network Laboratory™

## TBoy

- ◆ Redirect the Request to SafeWeb
- ◆ SafeWeb will send response using TBoy IP.

Outgoing packets to SafeWeb are blocked.

Visitors can download Triangle Boy (less than 1MB) from the SafeWeb site.

Incoming packets from SafeWeb have spoofed IP addresses and appear to originate from Triangle Boy PC.

Wireless & Multimedia Network Laboratory™

## P-MIP

- ◆ A paging area consists of one or more networks

Wireless & Multimedia Network Laboratory™

## Hawaii (Handoff-aware Wireless Access Internet Infrastructure)

Home domain: Home root router, MN.

Foreign domain: Foreign root router, Router A, Router B, Old BS, New BS, MN.

Internet.

Wireless & Multimedia Network Laboratory™