

無線網路多媒體系統

Wireless Multimedia System



WiMAX
Worldwide Interoperability
of Microwave Access

Dr. Eric Hsiaokuag Wu
hsiao@csie.ncu.edu.tw

<http://wmlab.csie.ncu.edu.tw/course/wms>

2007 Fall

First Week Agenda

- ◆ Course Preview
- ◆ Wireless Multimedia/Mobile Computing / Pervasive Computing
- ◆ Wireless Mobile Communications
- ◆ System Review and Fundamental Problems
- ◆ Next Week



Course Contents

- ◆ Fundamental Wireless Technology
 - Propagation Model
 - Wireless Medium Access
 - Transport Solutions
 - Ad hoc/Mesh Wireless System
 - Cellular System
 - Middleware Systems
 - Multimedia System

- ◆ Advanced Wireless Technology
 - Multicasting
 - Heterogeneous System
 - Routing Algorithms
 - QoS/ Reliable Transmissions



WiMAX Nomadic and Portable



802.16e PC Card

Non Line of Sight
Point to Multi-point

802.16

Line of Sight
BACKHAUL

802.16

Laptop Connected
Through 802.16

SEEKS BEST
CONNECTION

2 to 3 Kilometers Away

Telco Core
Network or
Private (Fiber)
Network

INTERNET
BACKBONE

Ref: Margaret LaBrecque , “Enabling Deployments through Standards and Certification,”
WiMax, 2003

Wireless & Multimedia Network Laboratory™

Wimax 802.16

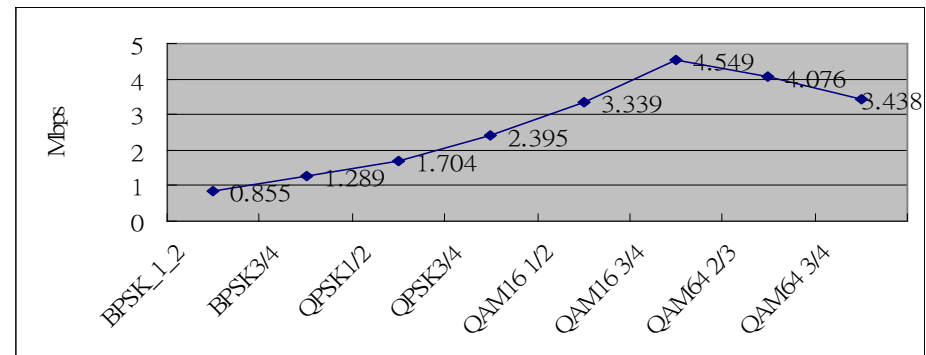
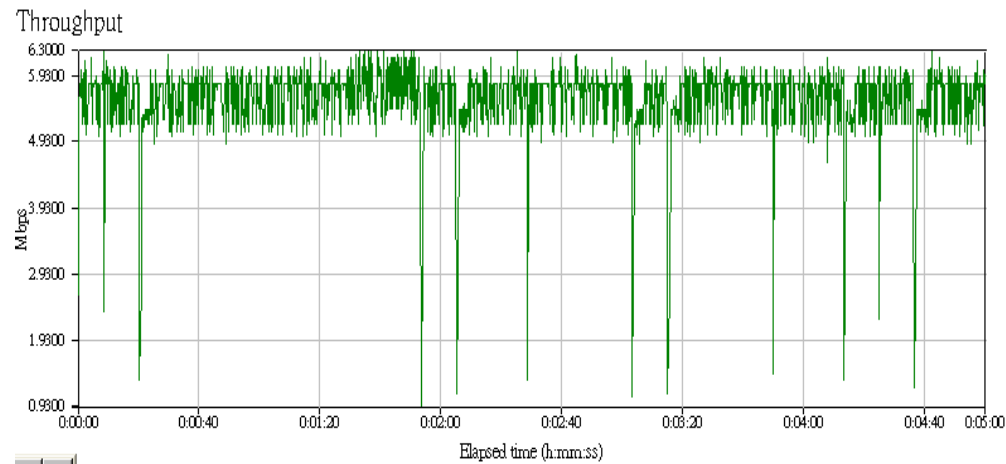
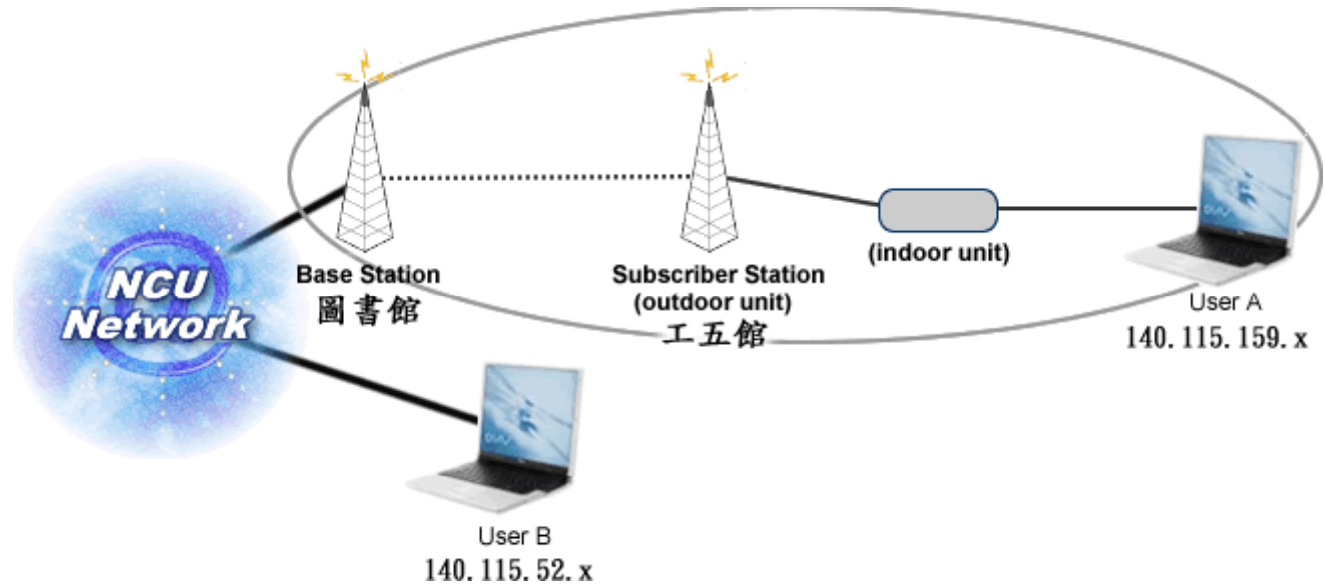

Roaming Across a variety of heterogeneous network and service environments

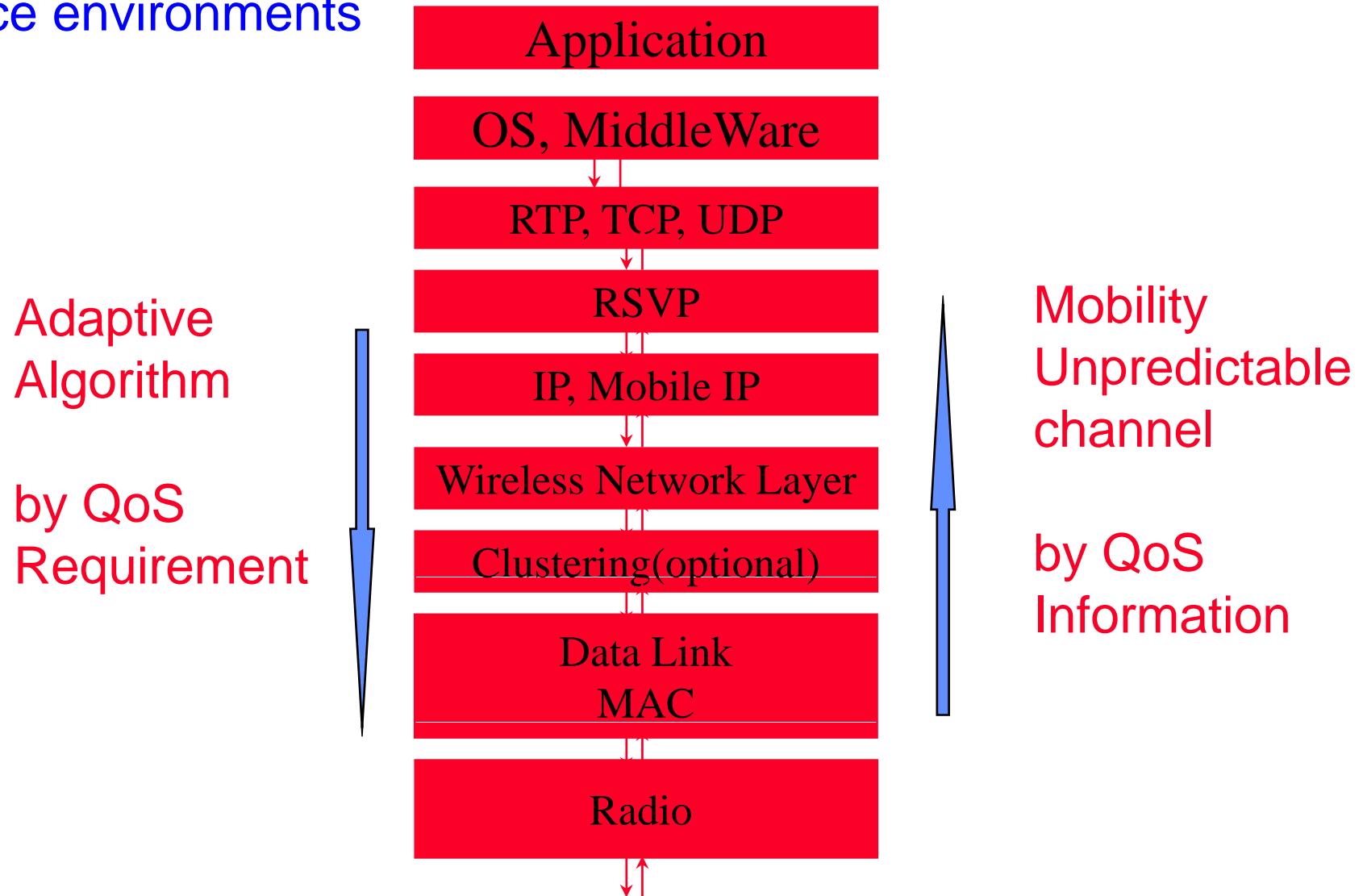

Growth in traffic in different access system and voice and data services

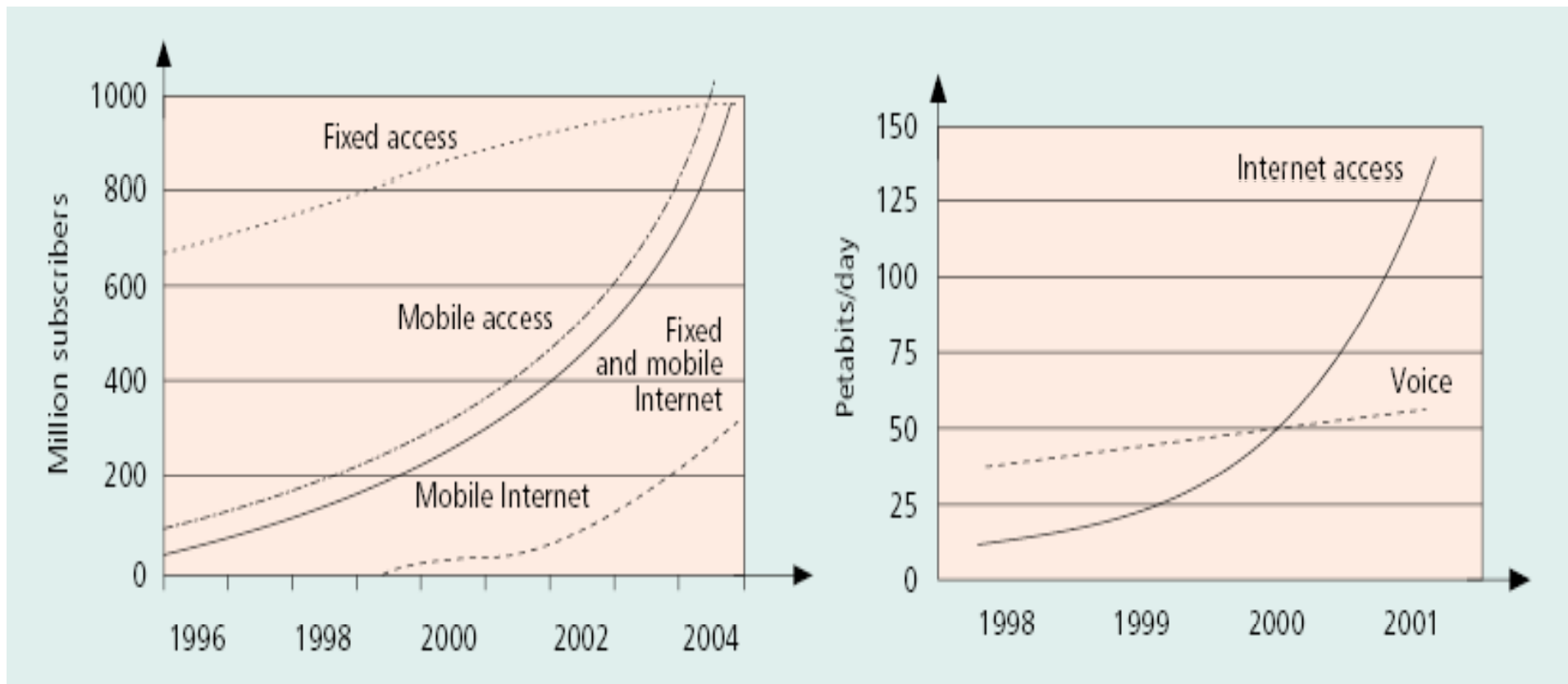

台灣行動電話發展趨勢圖

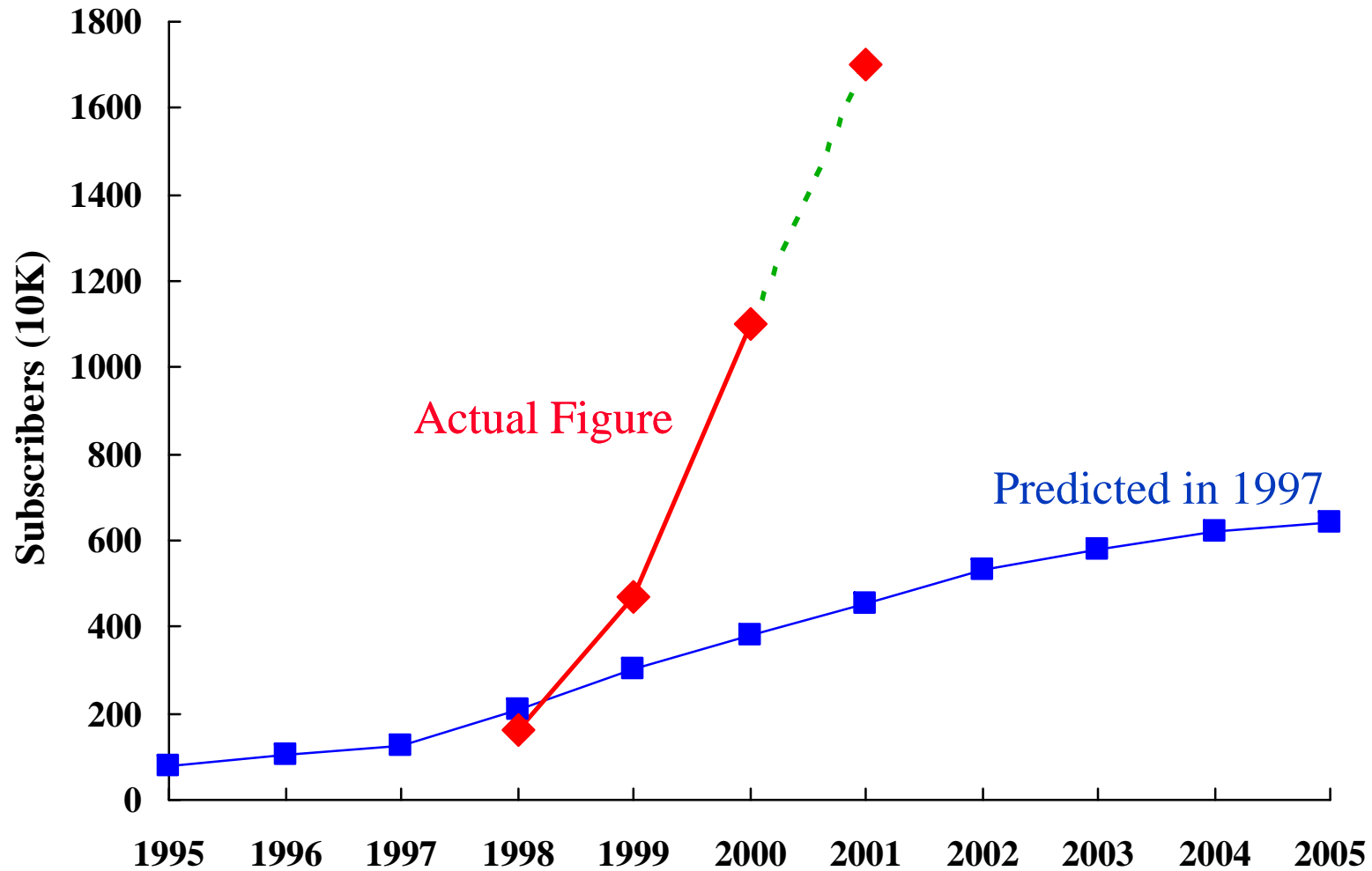

Forecast number of subscribers

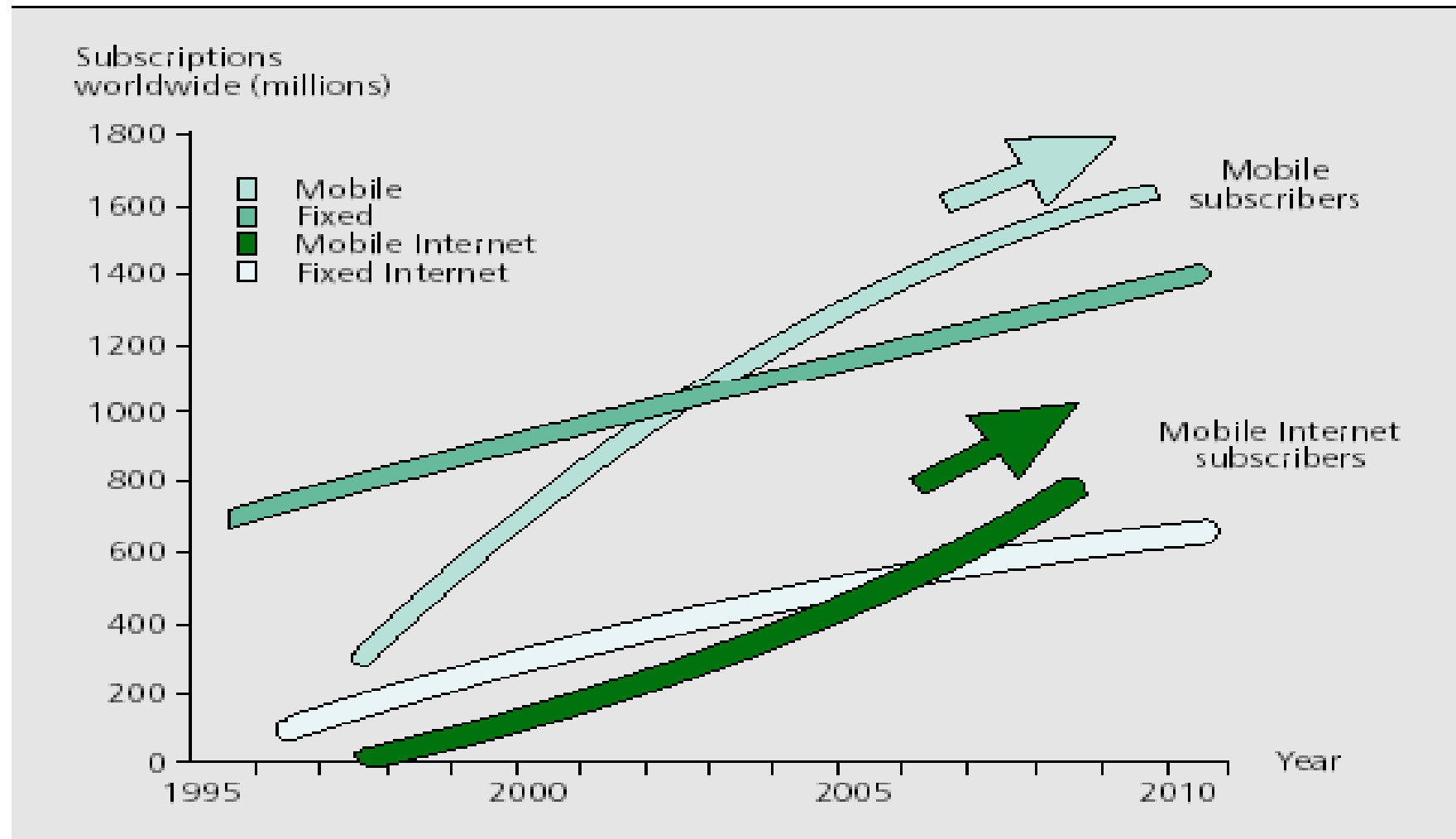

Ultra-Wideband Radio

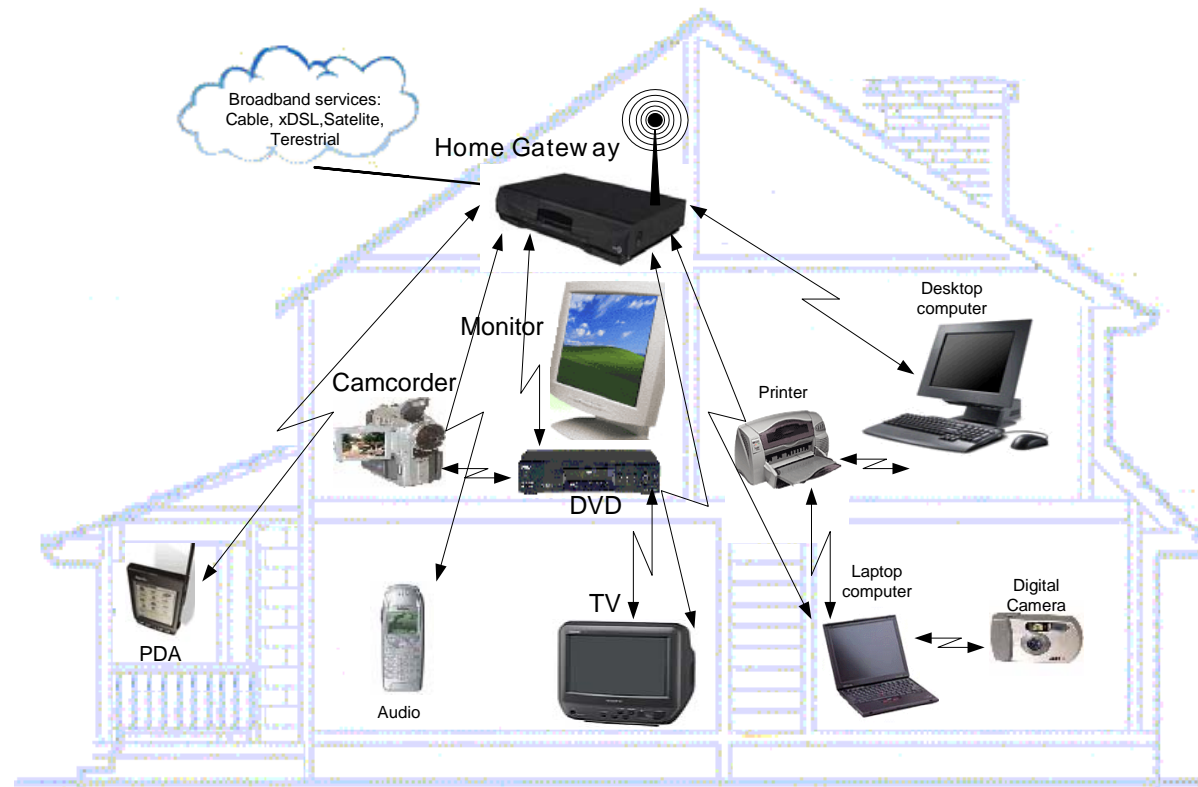

CR (Cognitive Radio)

- ◆ The CR idea was initially introduced by [Joseph Mitola](#). On average, only 2% of allocated spectrum in the U.S. is actually in use

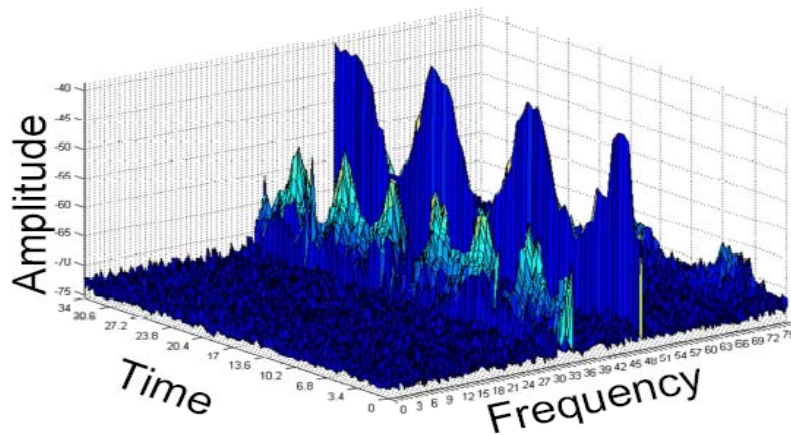
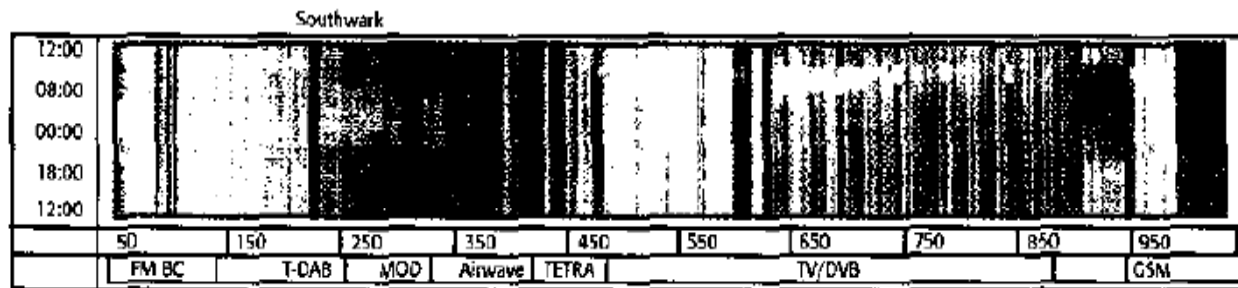

Multi-channel, Multi-Radio, MIMO

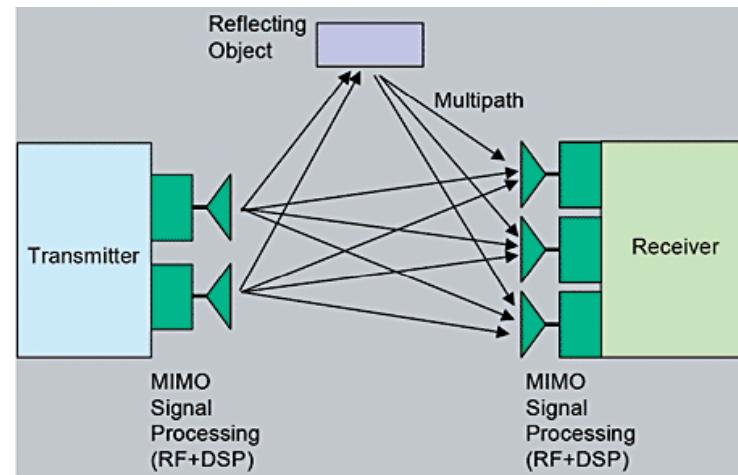
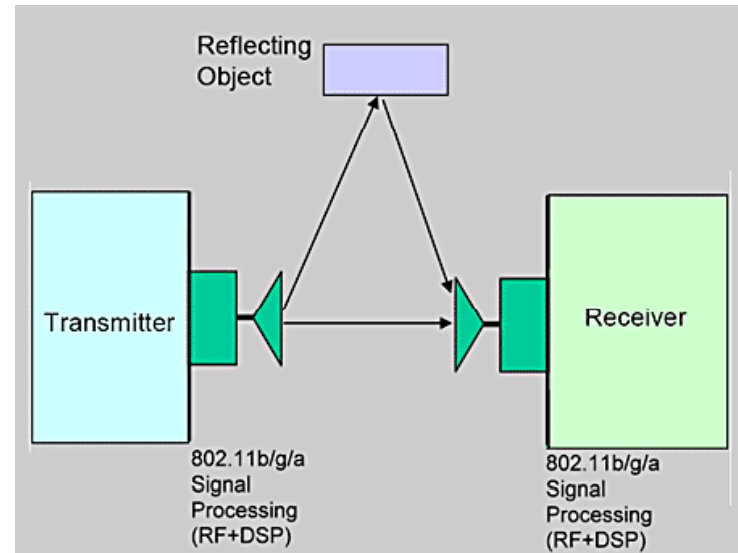

Wireless Mesh Network.

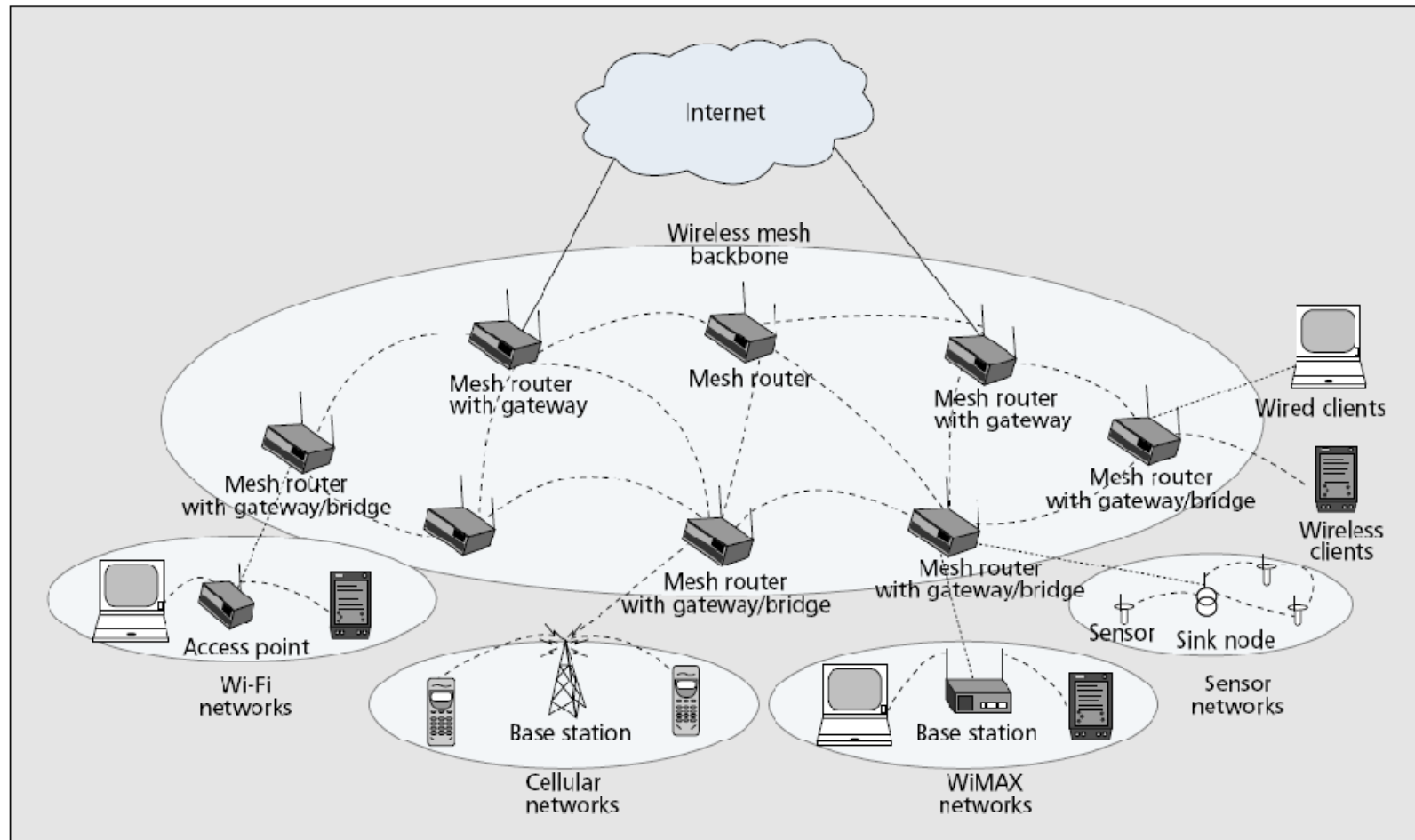

Mesh Network Scenario

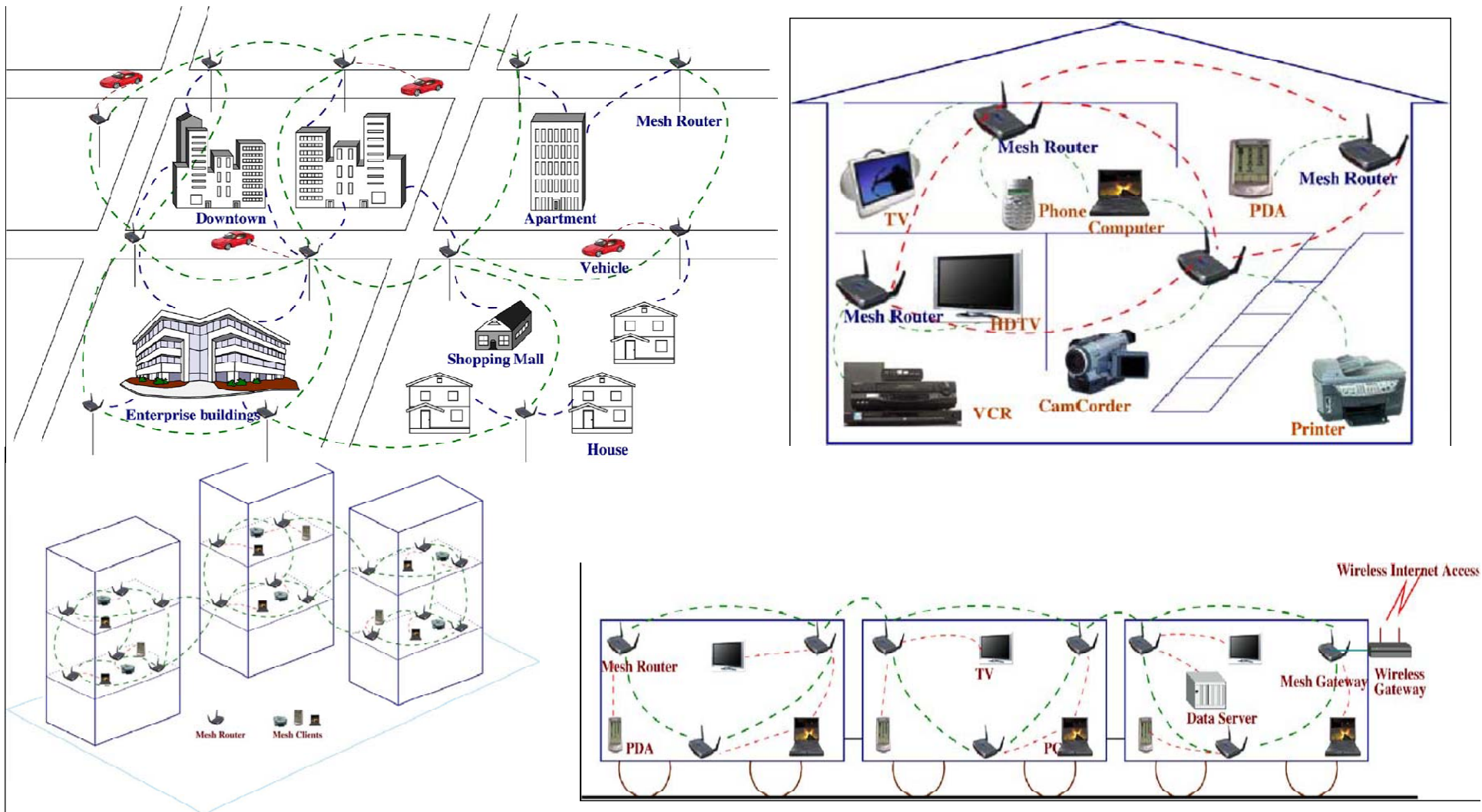

Aeronautical Communications

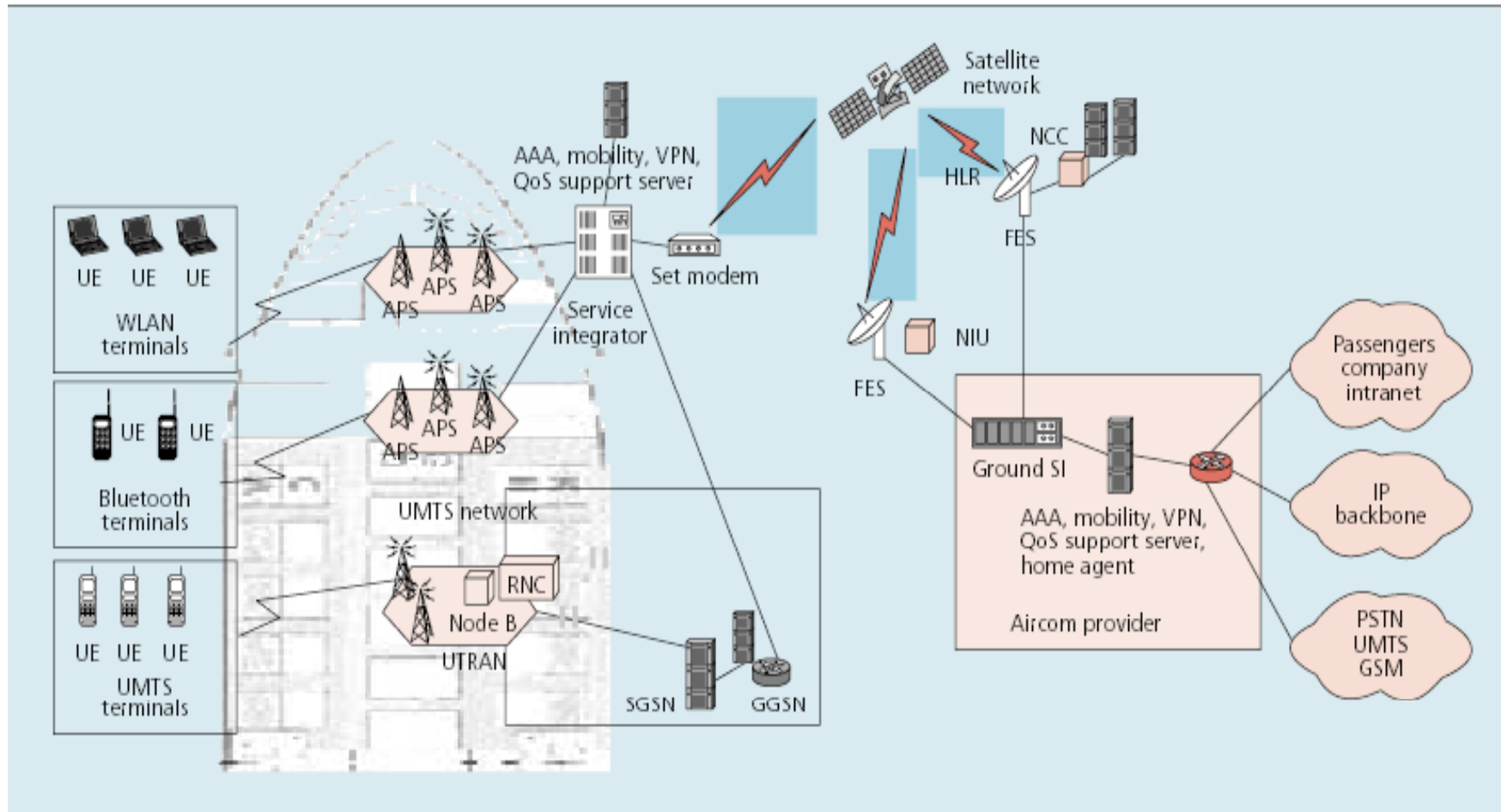

■ Figure 2. Aeronautical communications network architecture.

Multimedia over IP

IP Mobility & All IP Multimedia Towards Wireless Internet Network Vision

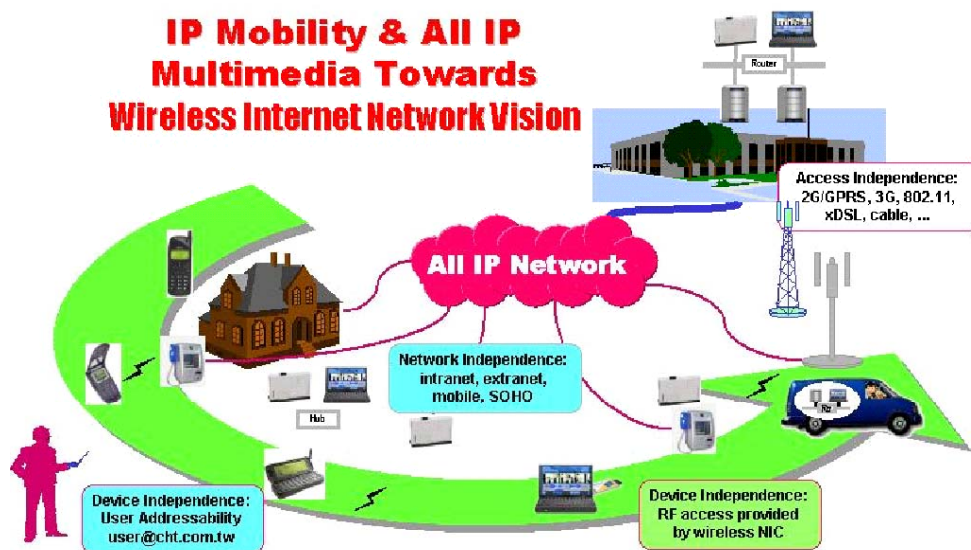

IMS Service Scenario

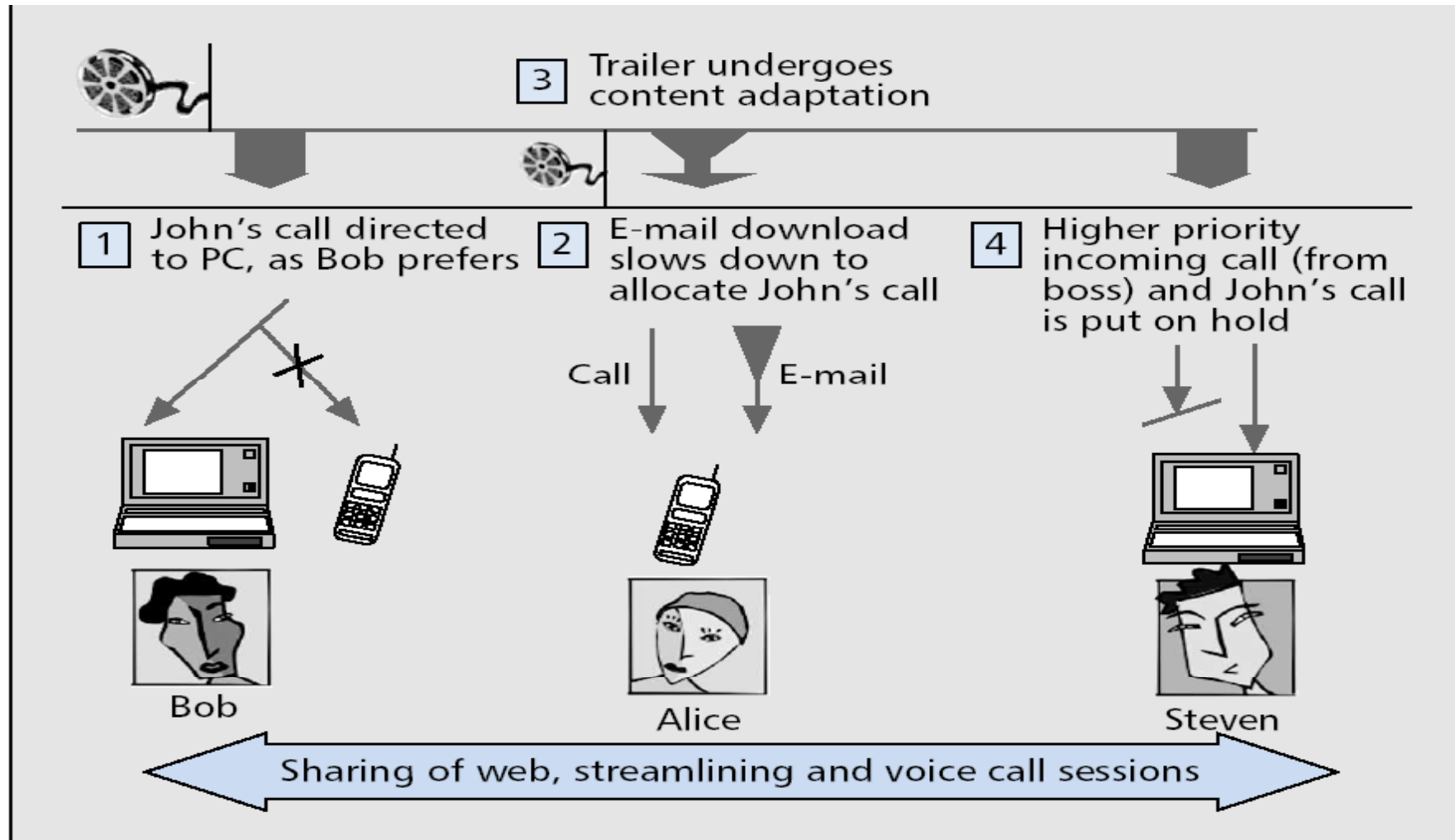

Context Aware Communiation

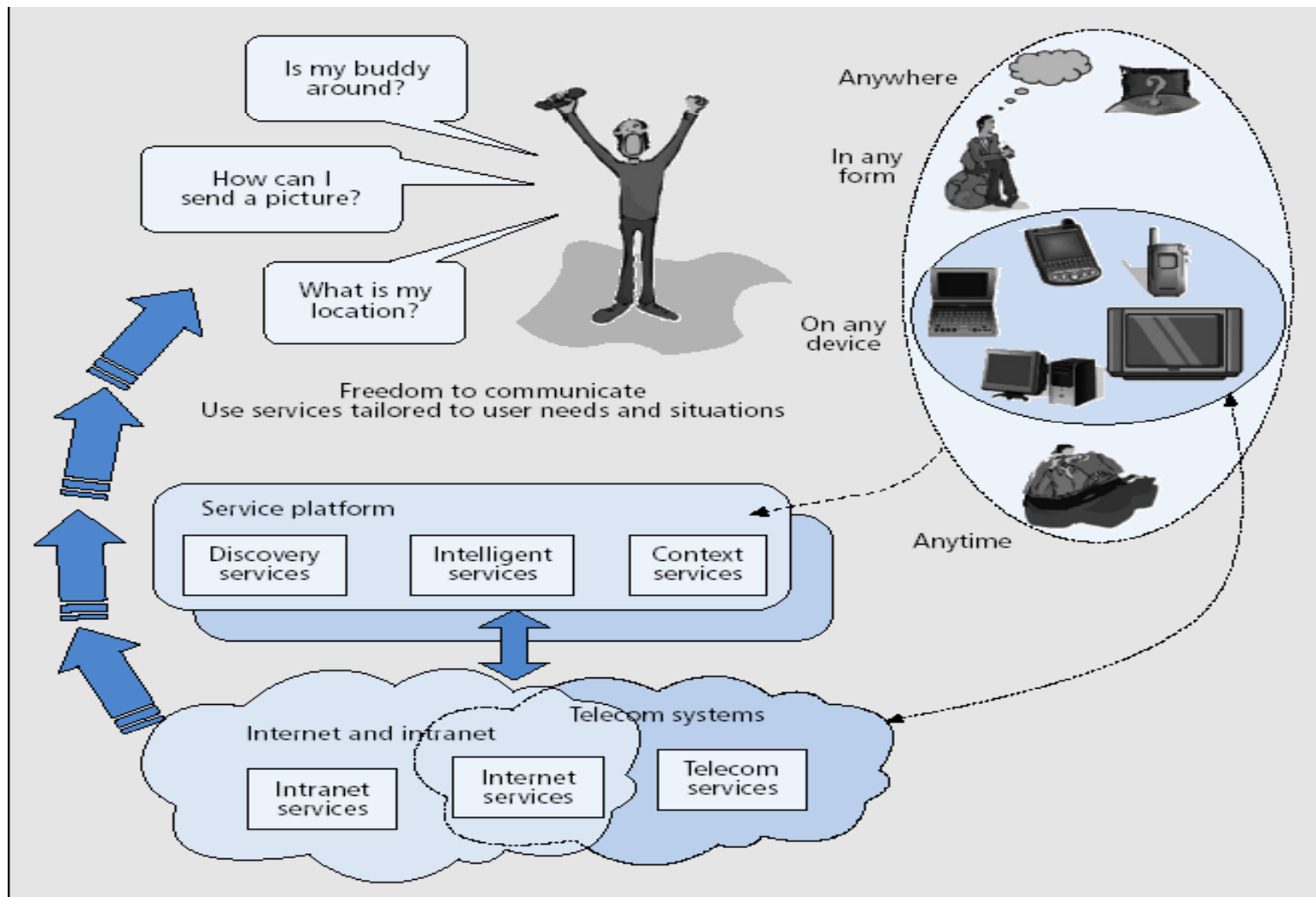

Business Finder

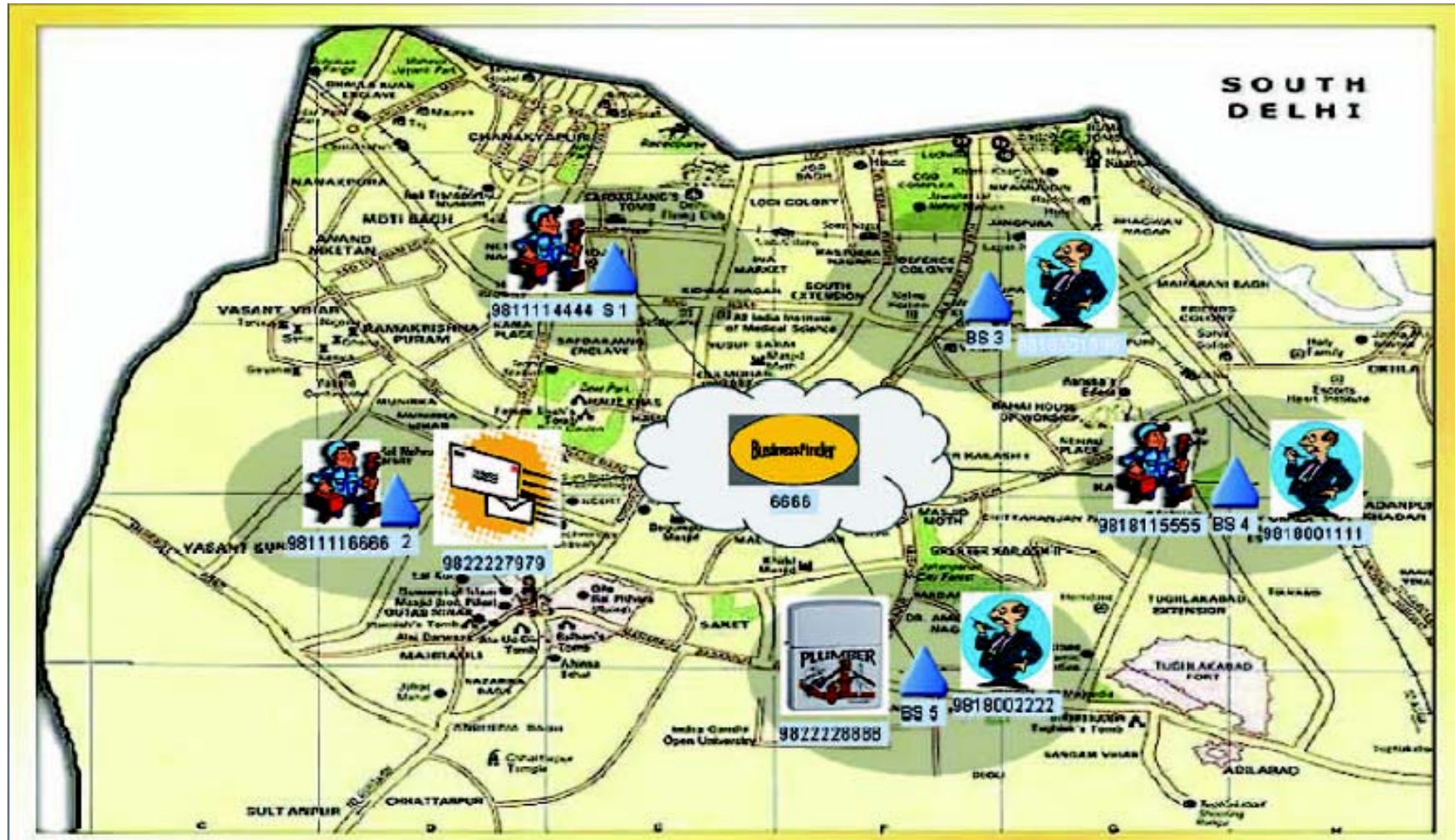

Adaptive Applications



Video



Audio



Graph



Text

Varied type of service



Adaptive application coding

High Quality Low

Situation-Aware Wireless Networks

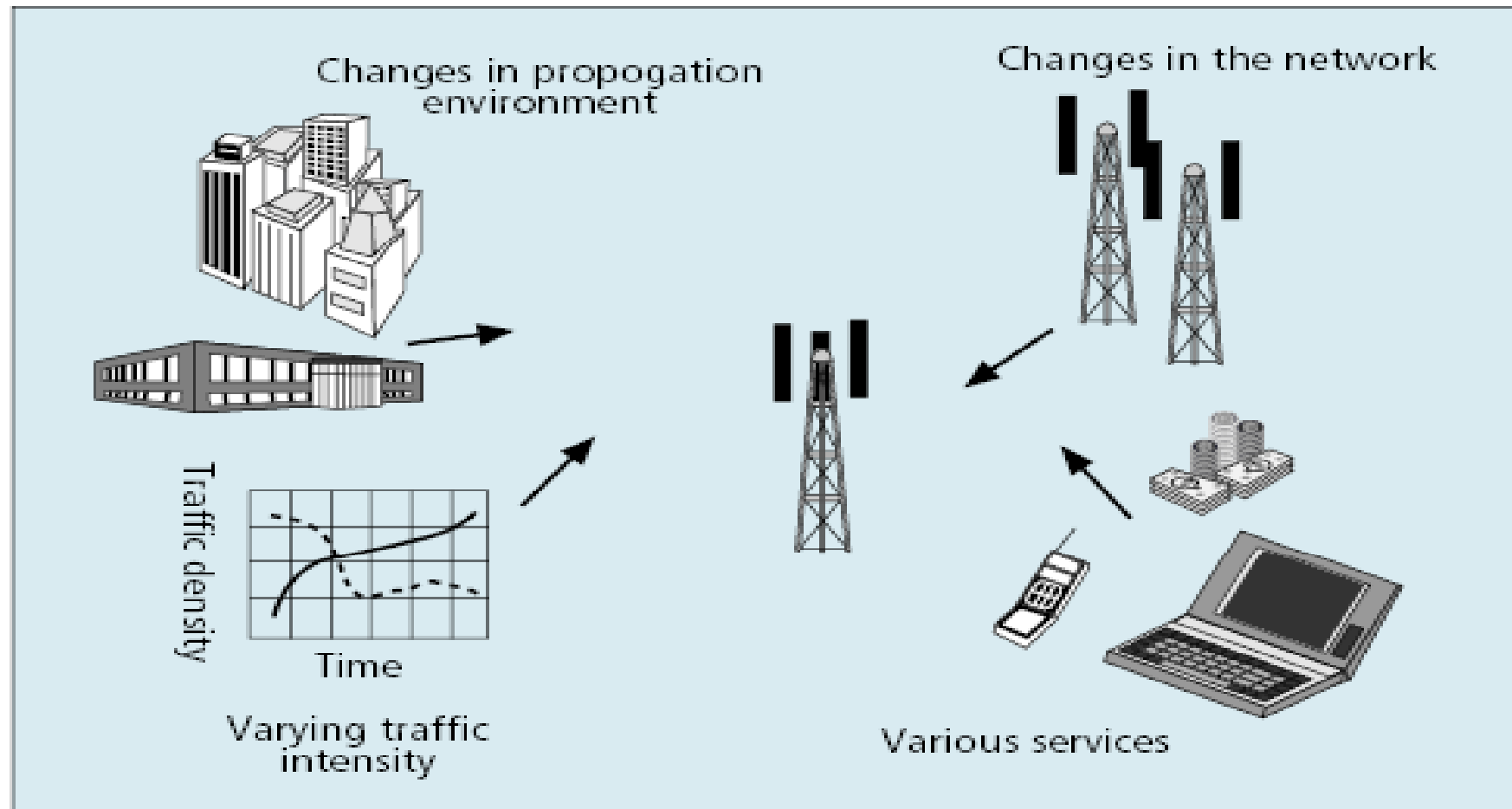

■ Figure 4. *Situation awareness functionality.*

Network Mobility Management

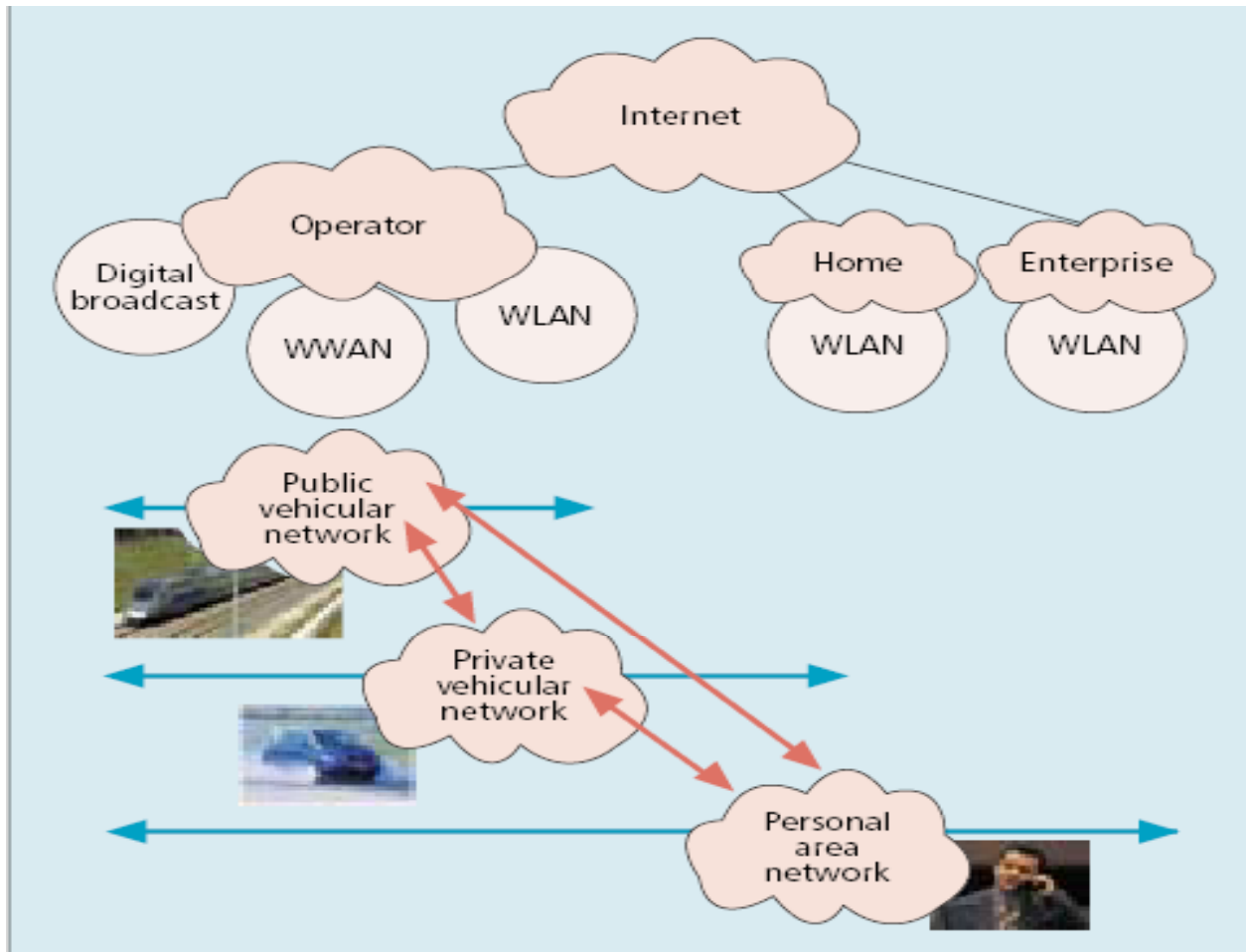

■ Figure 1. A mobile network in a B3G system.

Expectation of the Class

- ◆ Basic Understanding of PCS world
- ◆ Being able to do the wireless research
- ◆ Developing the capability to invent the key wireless applications

Course Process

- ◆ Paper reading and your presentations
- ◆ Wireless Multimedia Applications Exercises

Mobile Computing



Mobile phone today = multipurpose terminal for ...



Reading list for This Lecture

- ◆ Required Reading:

(Cfox95) D. Cox, "Wireless Personal Communications: What is it?," IEEE Personal Communication Magazine, (April 1995) pp.20-35

(S.2001) M. Satyanarayanan, "Pervasive Computing: Vision and Challenges", IEEE Personal Communication Magazine, (August 2001), pp.10-17

(Bi2001) Qi Bi, George I. Zysman, and Hank Menkes, "Wireless Mobile Communications at the Start of the 21 Century", IEEE Communication Magazine (January 2001), pp. 110-116

Further Reading

(Bolcskei2001) H. Bolcskei, A. J. Paulraj, K. V. S. Hari, and R. U. Nabar, "Fixed Broadband Wireless Access: State of the Art, Challenges, and Future Directions", IEEE Communication Magazine

Mobile Computing

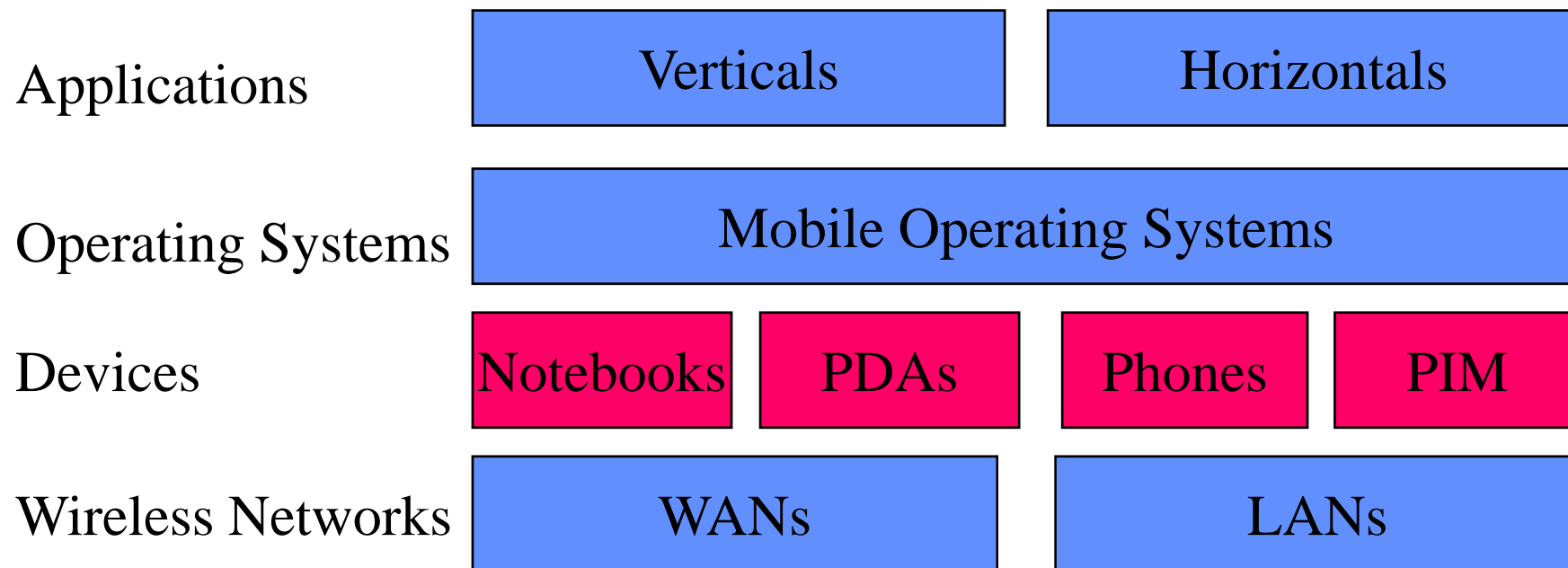

Mobile Computing

- ◆ information processing in general
 - not just communication or just computing, but both
- ◆ Any medium or combination of medium
 - process not just telephone voice or just data, but multimedia
- ◆ Mobility
 - components of the systems may be
 - ◆ moving, tether-less (wireless), portable
 - uses of the system may be moving

Why should we care ?



- ◆ Reason # 1 : \$\$\$ & jobs
- ◆ Explosive growth of wireless voice, paging, and data services
 - 35-60 percent annual growth in the past decade
 - mobile phones in US will be 42 % of fixed -line phones by 2000
 - 700 million mobile users at the end of 2000
 - One billion expected by 2003
- ◆ Big demand for portable communicators and computers
 - 2 M portable computer in 1988 to 74.1 M units in 1998

Is there a more “academic” reason ?

- ◆ Reason # 2: a next step in the evolution of information system
- ◆ Evolution from personal computing to networked computing to mobile computing
- ◆ Evolution from wired telephony to cordless telephony to mobile cellular telephony
- ◆ At the same time, unification of computing and communication



Mobile Multimedia Systems

- ◆ Ubiquitous information access (everybody else)
 - e.g. wireless computing, mobile computing, nomadic computing
 - information distributed everywhere by “the net”
 - users carry (wireless) terminals to access the information services
 - terminal is the universal service access device
 - terminals adapt to location and services
 - Knowledge-based society
- ◆ Flexible Users Choices
 - In terms of access, service, content
 - Any where, anytime, any terminal equipments
- ◆ Wearable Computing terminal / Mobile Broadband services (MBS)



Pervasive Computing

- ◆ Technology that disappears
 - The most profound technologies are those that disappear. They weave themselves into the fabric of everyday life until they are indistinguishable from it”.
- ◆ Ubiquitous (Invisible) Computing (Xerox PARC)
 - Cheap computers of different scale and types embedded everywhere
 - Potentially 100s of computers per room that disappear into background (e.g. active badge, tabs, pads, live boards..)
 - User centric, not terminal centric
 - Computers swapped and shared among users
- ◆ Effective Use of Smart Spaces
- ◆ Invisibility
- ◆ Localized Scalability
- ◆ Masking Uneven Conditioning



Support for Pervasive Computing

- ◆ User Intent
- ◆ Cyber Foraging
- ◆ Adaptation Strategy
- ◆ High-Level Energy Management
- ◆ Balancing Pro-activity and Transparency
- ◆ Privacy and Trust
- ◆ Impact on Layering



Pervasive Computing

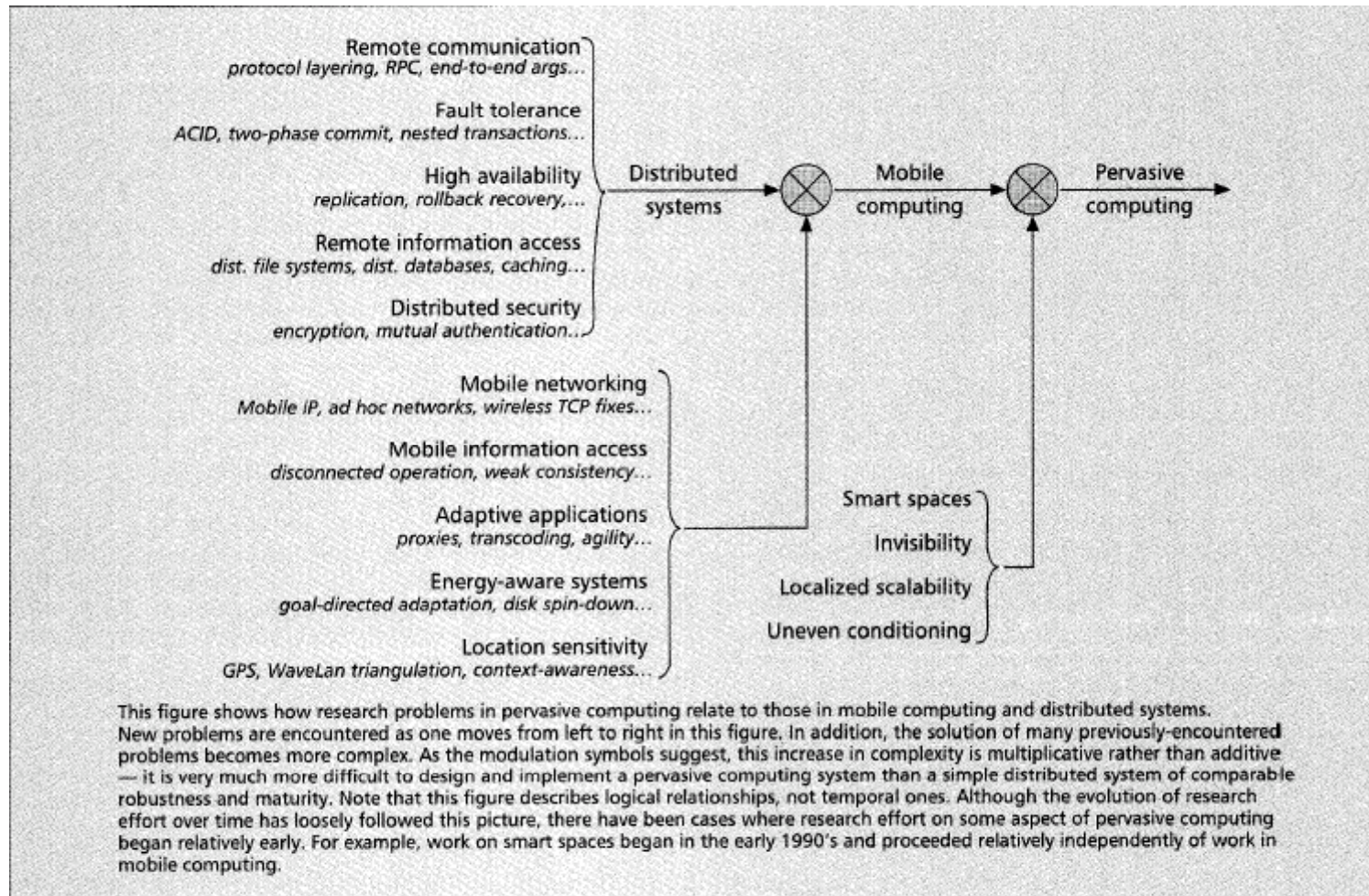

■ Figure 1. Taxonomy of computer systems research problems in pervasive computing.

Aura Client

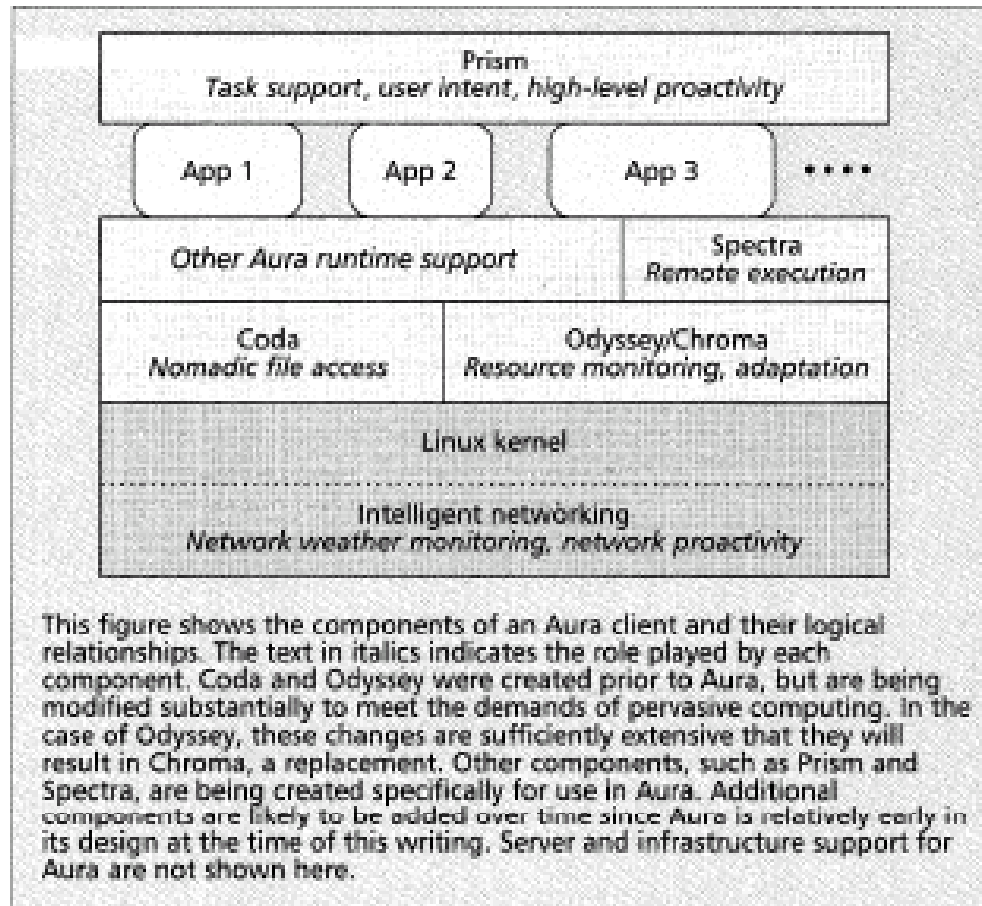

■ **Figure 2.** *The structure of an Aura client.*



Wireless Communications



Mobile Communications

Fixed Broadband Wireless Communications

Evolution of Mobile Wireless Systems

- ◆ First Generation : Analog – Voice
 - Analog modulation
 - Cellular phone (AMPS) with manual roaming
 - Cordless phones
 - Packet radio networks
- ◆ Second Generation : Digital - Voice & Data
 - WAP (wireless application protocol)
 - 2.5 G GPRS
 - Wireless data LANs (802.11), MANs (Metricom), WANs (CDPD, ARDIS, RAM)
- ◆ Third Generation: Digital – Multimedia
 - Unified digital wireless access anytime, anywhere
 - Voice, data, images, video, music, sensor etc.
- ◆ 4G~ Life after Third-Generation Mobile Communications

Cellular Service Subscription

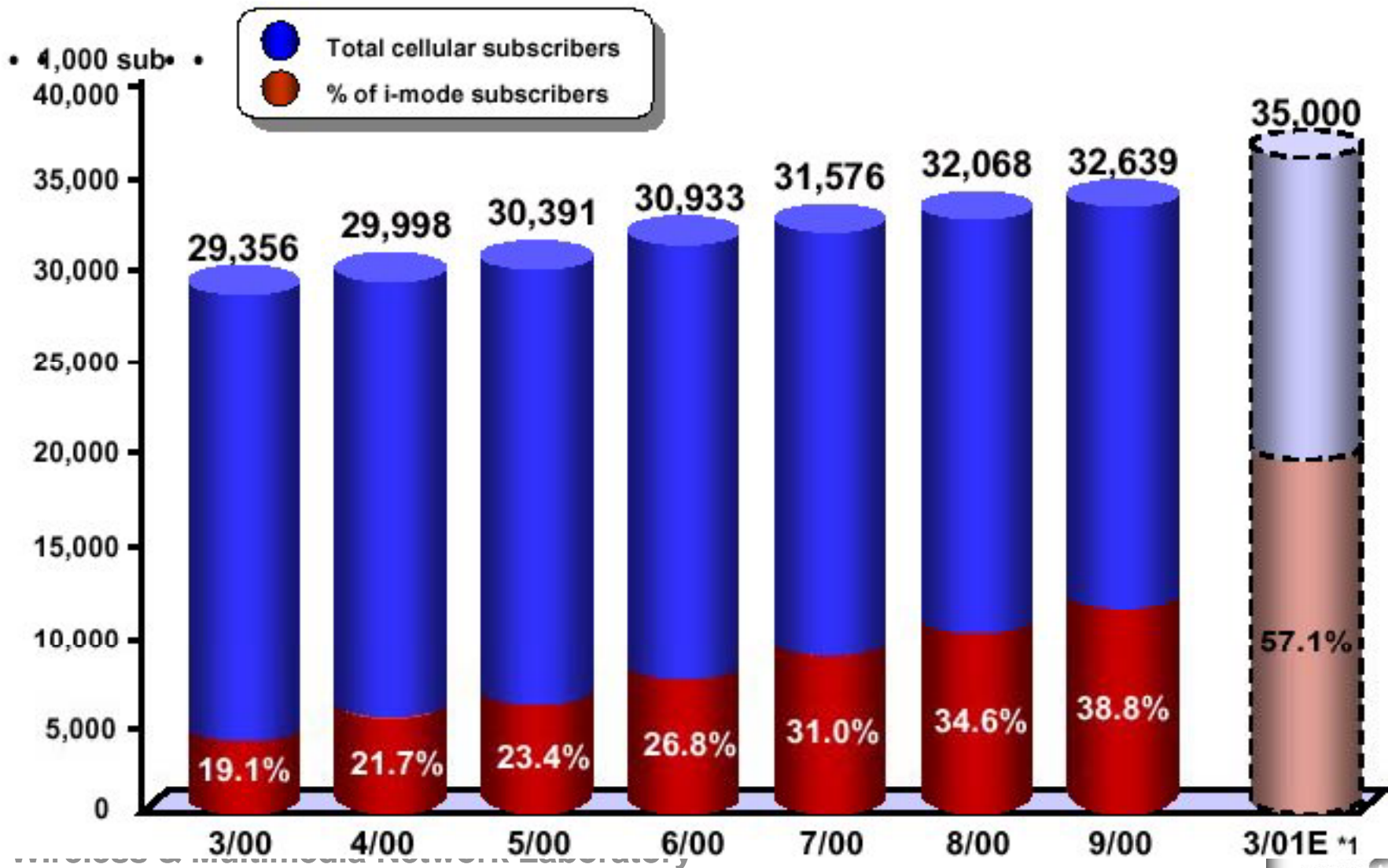

Wireless Personal Communications

- ◆ What is it?
 - Cellular telephone
 - Cordless telephone
 - Paging systems
 - Wide area data networks
 - Local area data networks
- ◆ Many ways to segment PCS
 - Applications
 - Extent of coverage
 - Degree of mobility (speed, area)
 - Circuit switched voice vs. packet-switched data
 - Mode of communication (messaging, two-way real time, paging, agents)
 - User location (indoor vs. outdoor, train, airplane)
- ◆ **Common ingredients in all PCS activity**
 - Desire for mobility in communications
 - Desire to be free from tethers

2000 Market Share

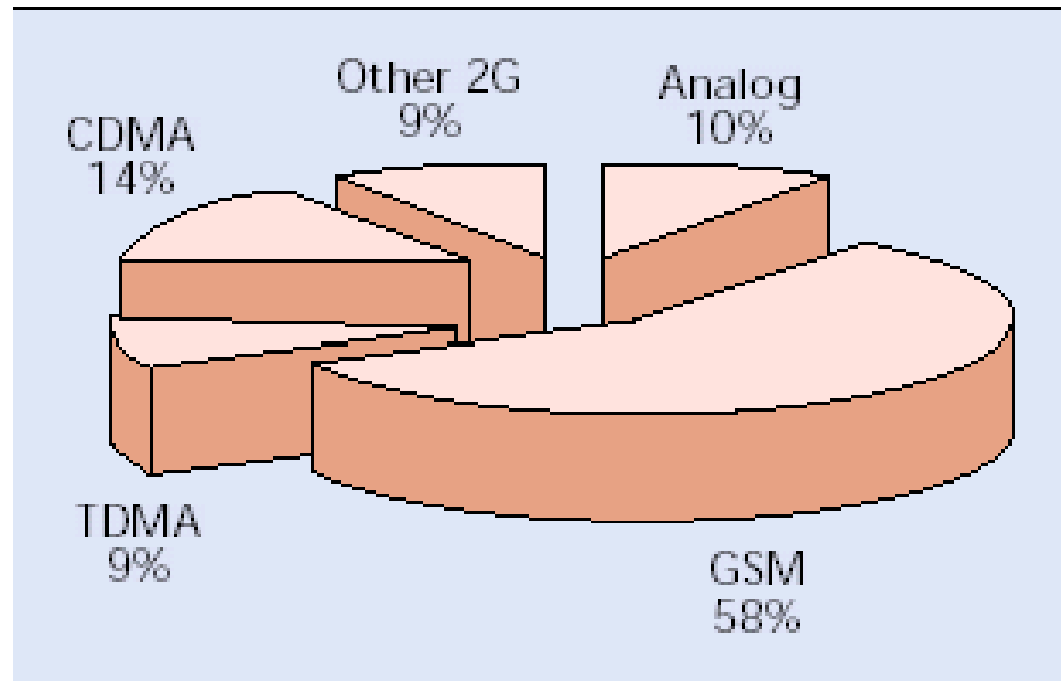

■ **Figure 5.** *Estimated market shares of 1G and 2G wireless mobile systems in 2000.*

Mobile Terminal Growth

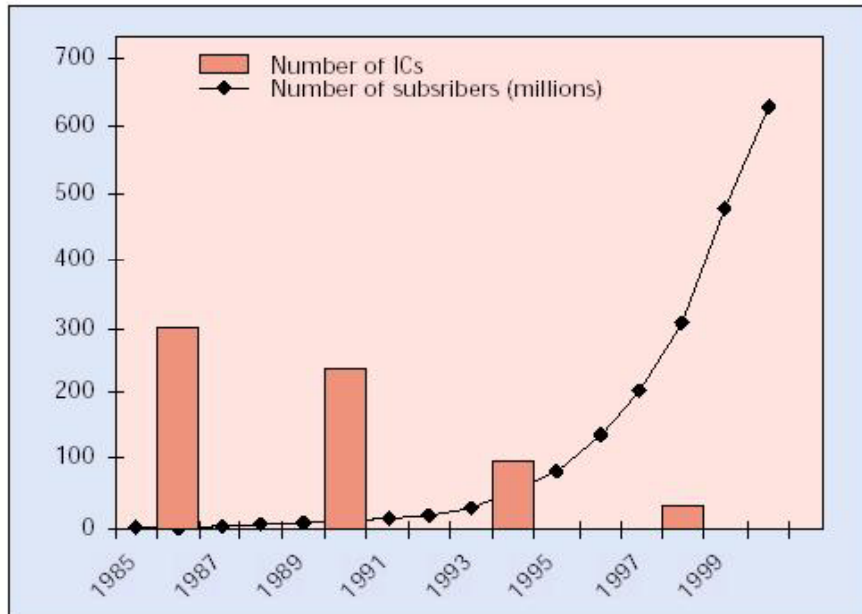

■ Figure 1. Subscriber growth and IC reduction in mobile terminals.

QUALCOMM

> Easy Migration from cdmaOne to 3G



Time to Market



Simple IS-95 to cdma2000 conversion

GPRS Architecture

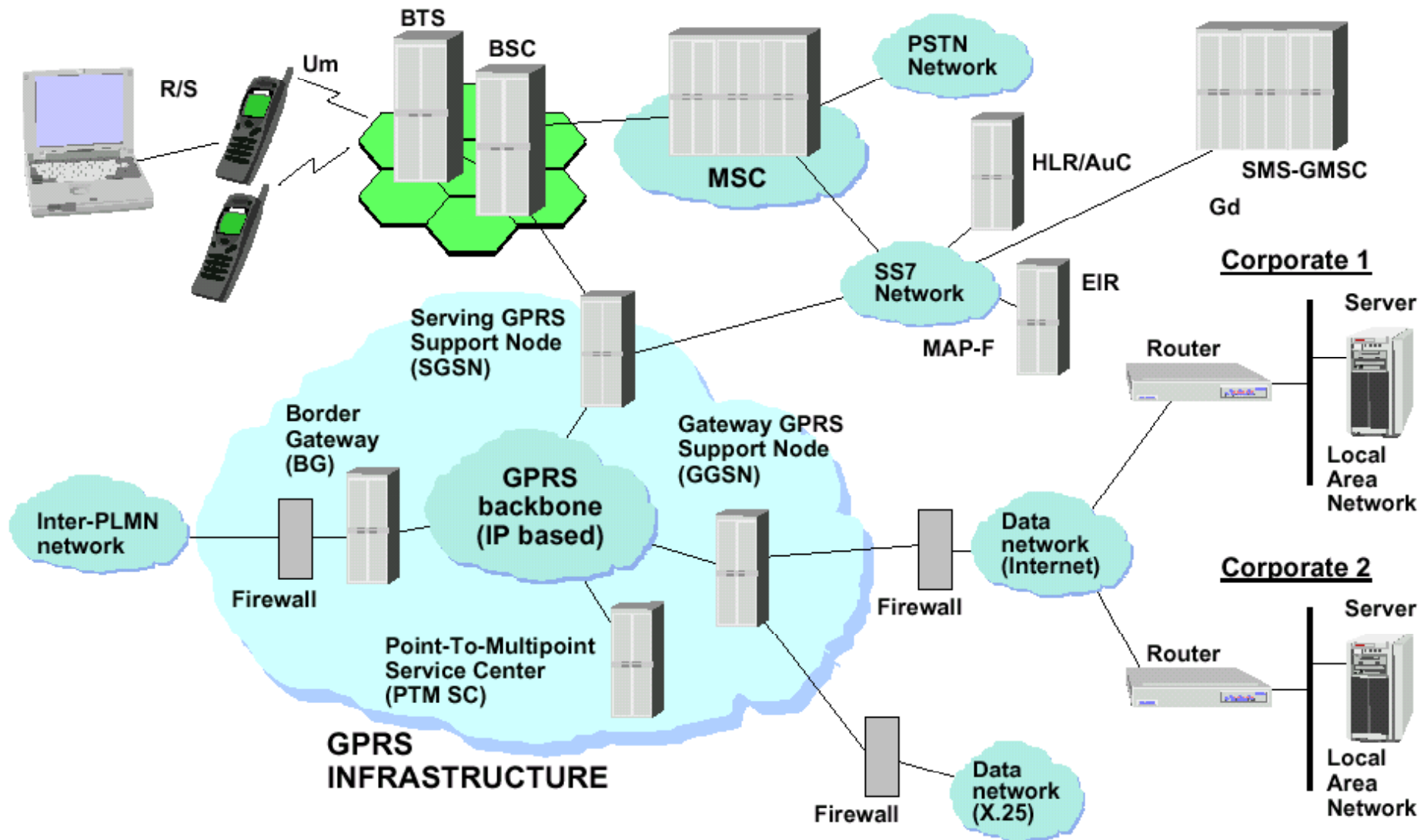

RS Spectrum Allocation

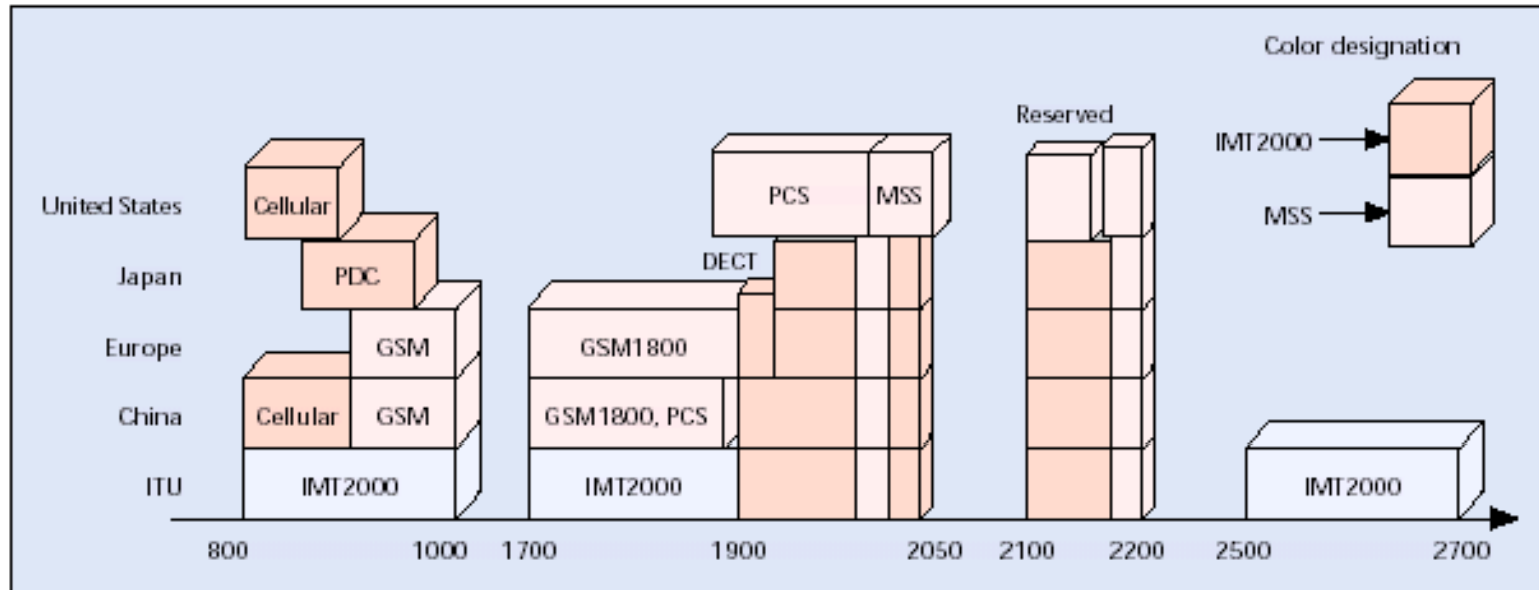
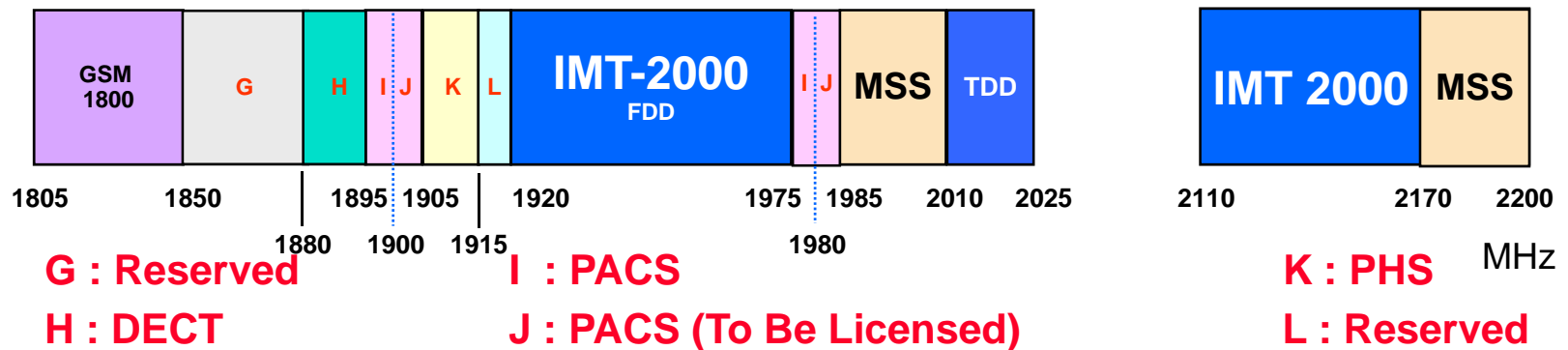
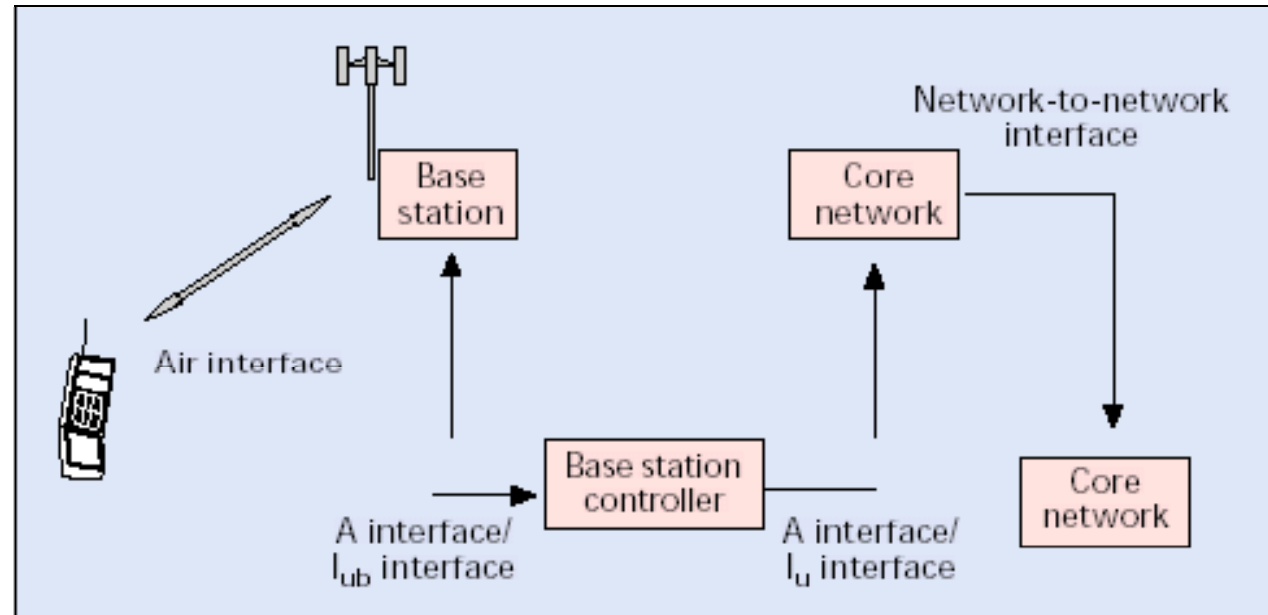

Figure 2. RF spectrum allocation in major regions.



Wireless Mobile Interface



■ Figure 4. *Wireless mobile system interface definition.*

Elements of UMTS Architecture

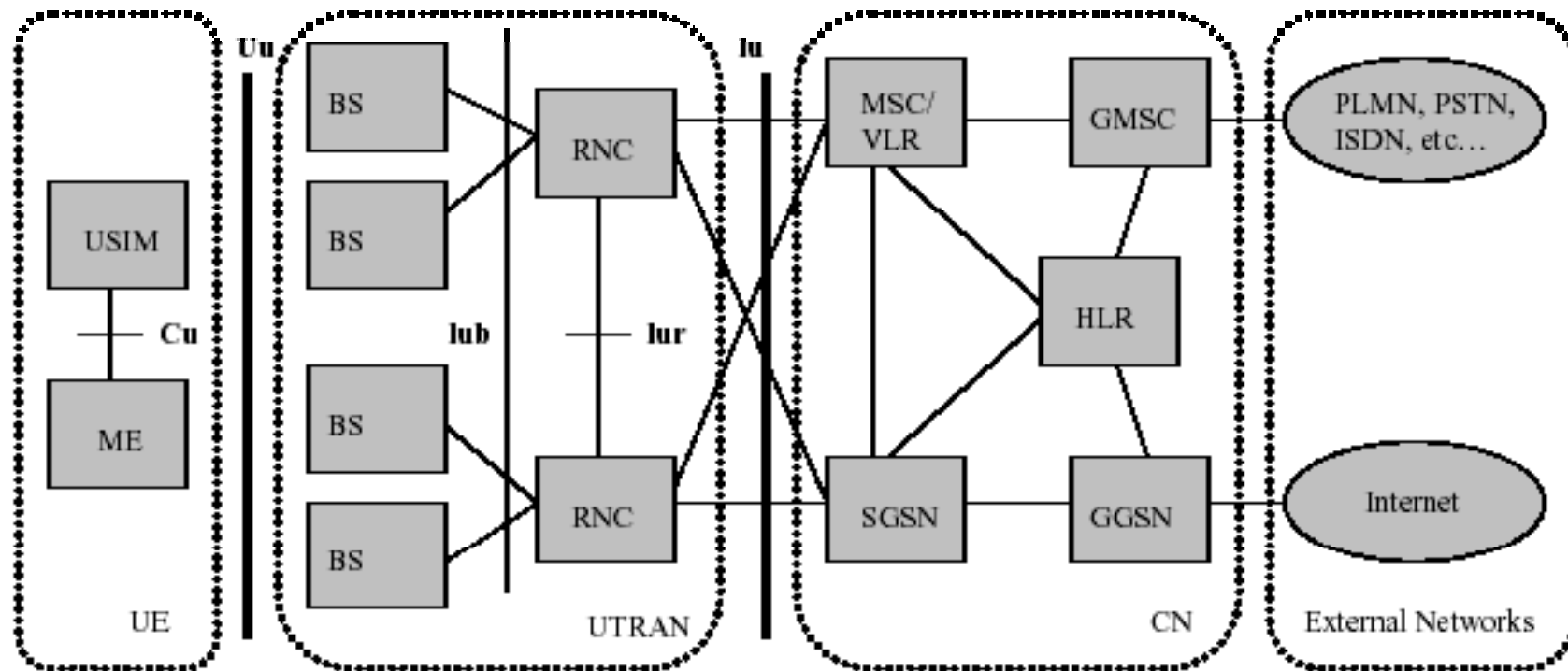

第三代行動電話之技術標準



Modular IMT-2000 Harmonization

Paired spectrum

Unpaired spectrum

(Terrestrial Component)

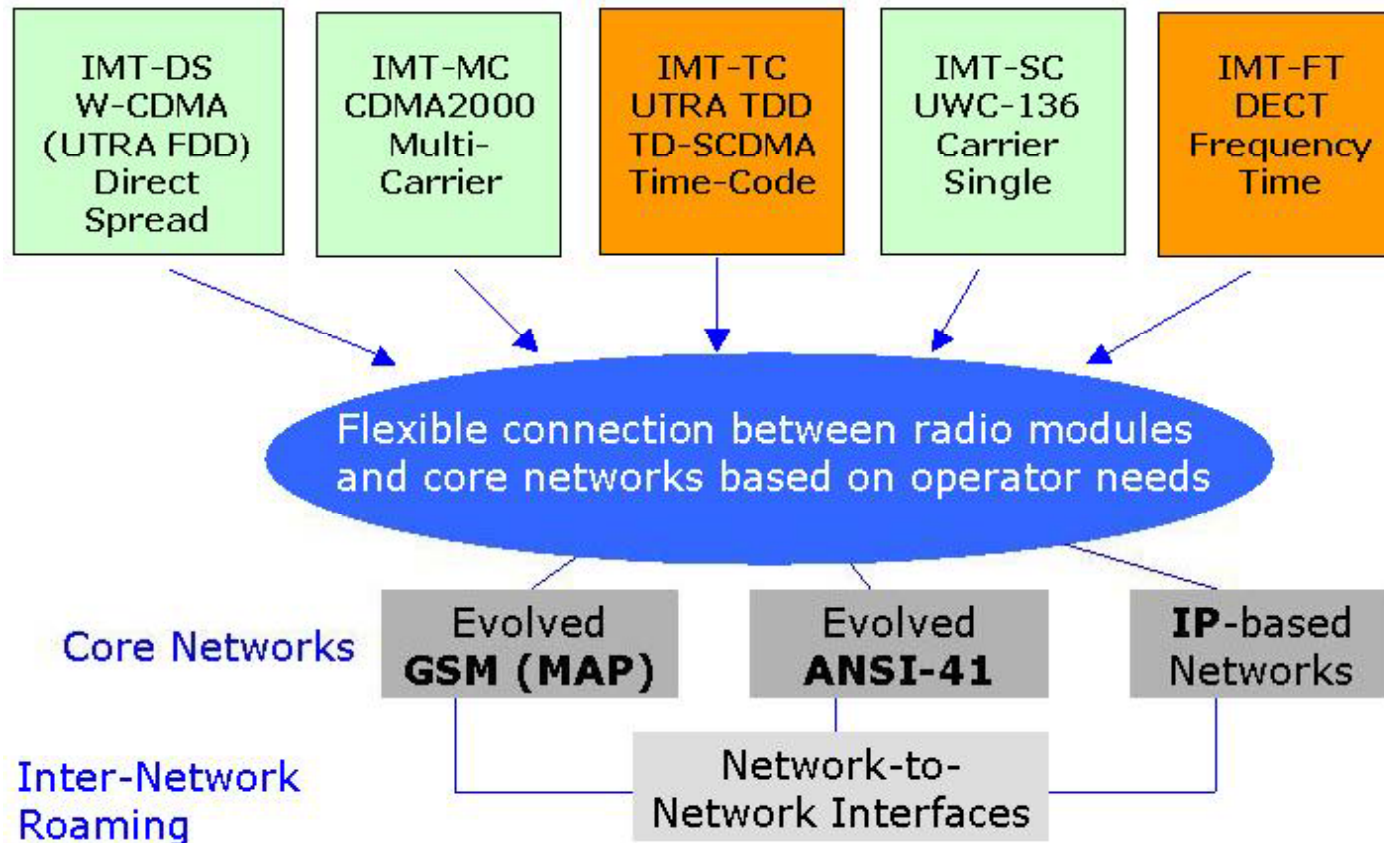

Location-Based Applications

Figure 1. A typical location data transaction

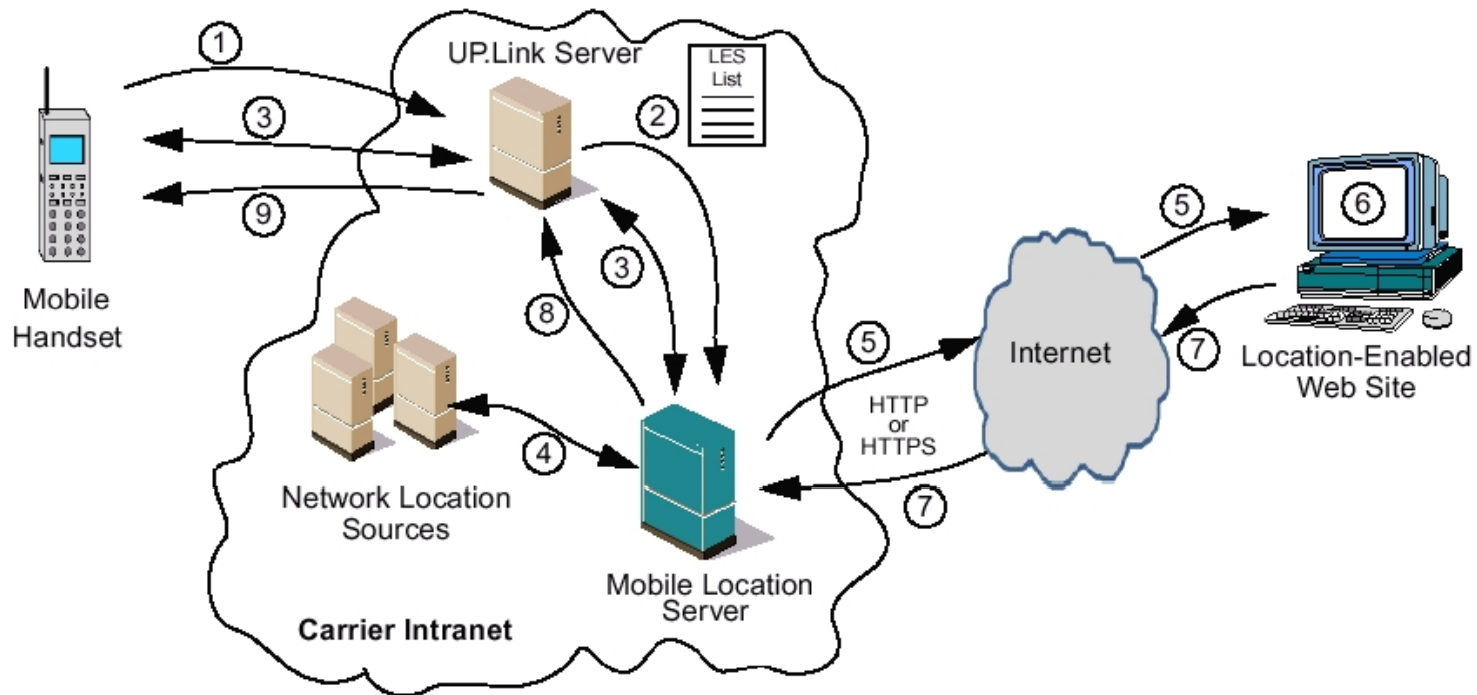

3G-Network integration

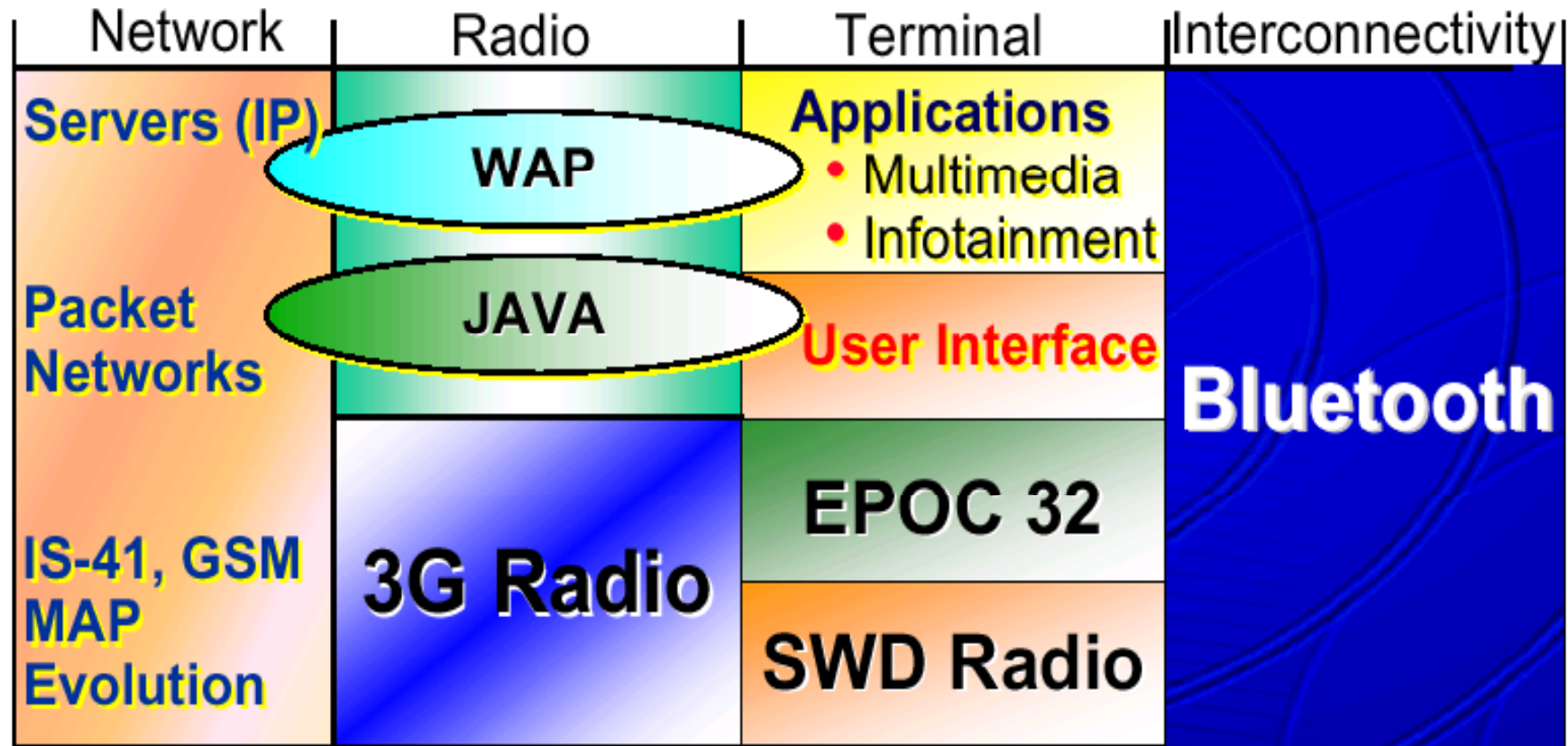

3GPP-Release 5 IMS & HSDPA

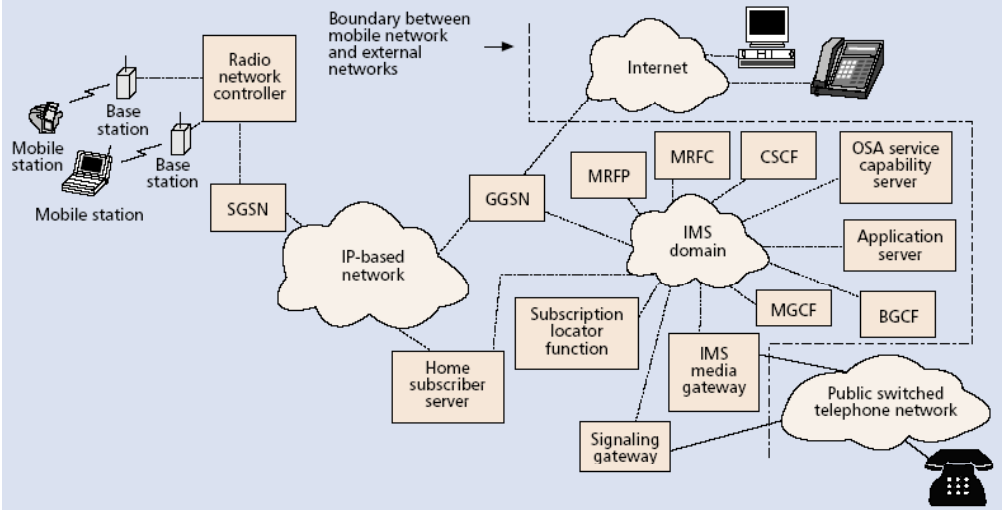
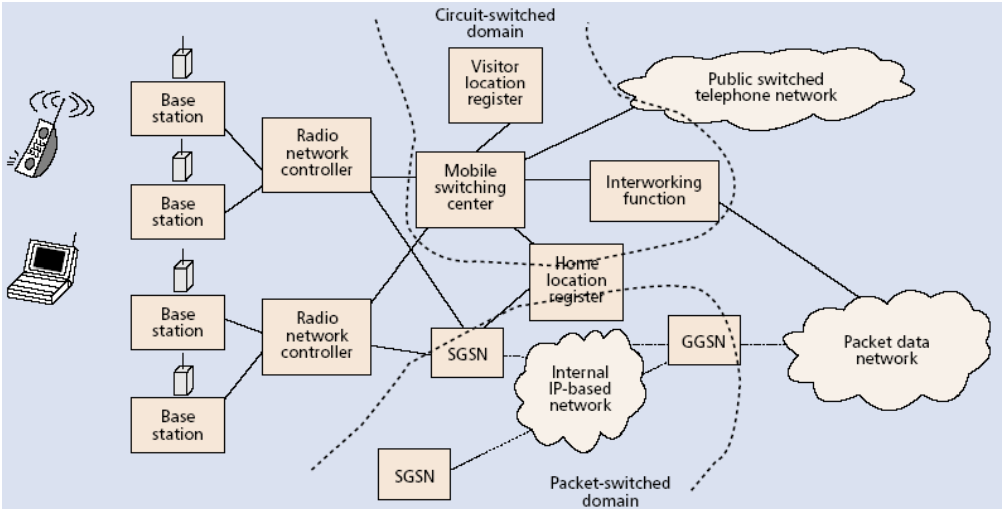

Mobile Broadband System

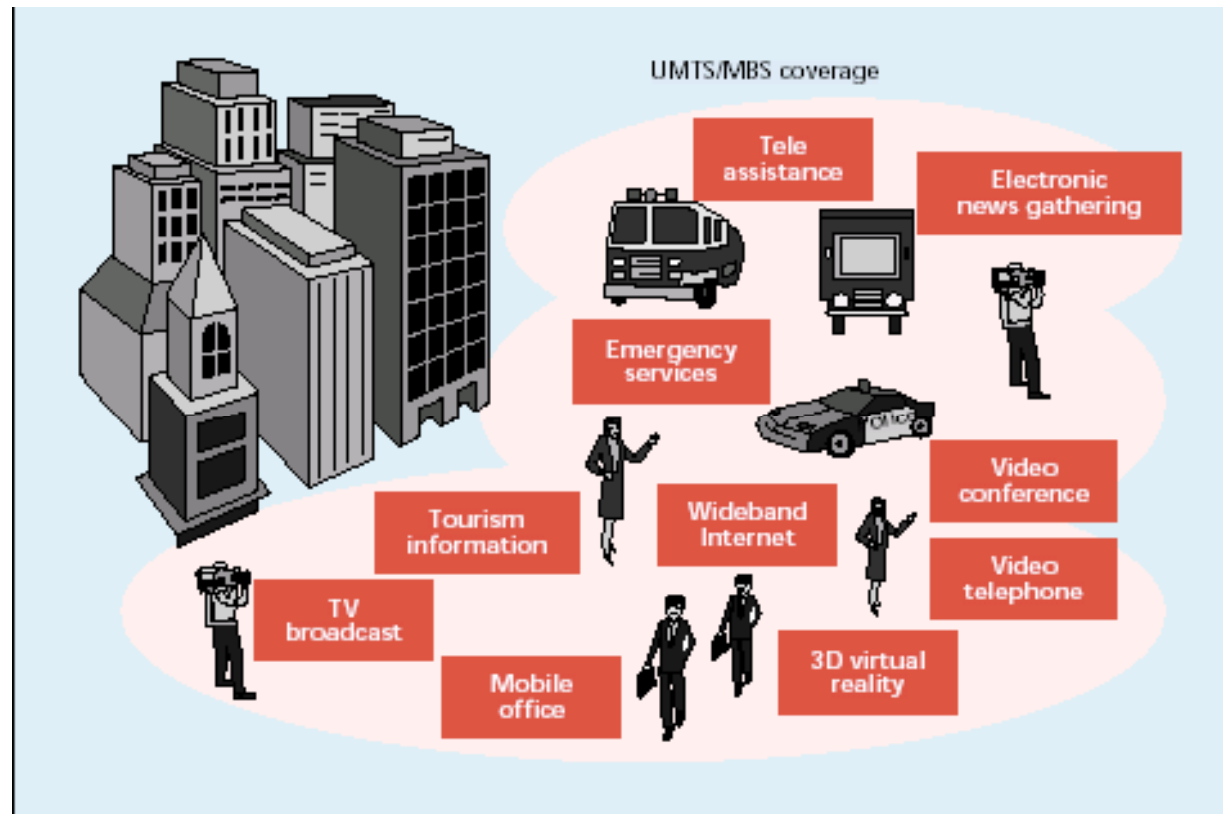

■ Figure 1. MBS and UMTS coverage and applications.

Mobile System Evolution

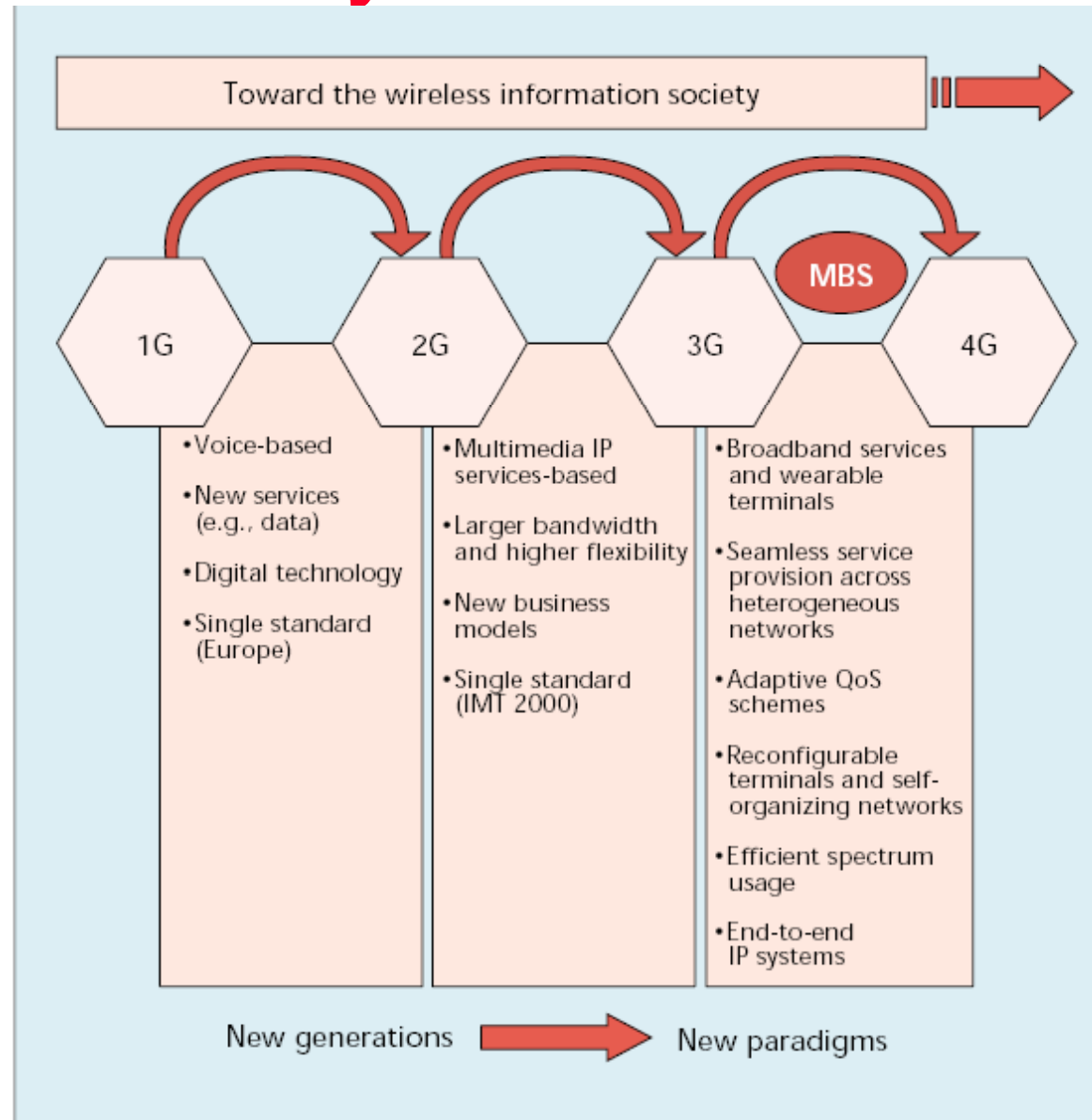

Wireless & Multimedia **Figure 5.** *Mobile communication systems evolution.*

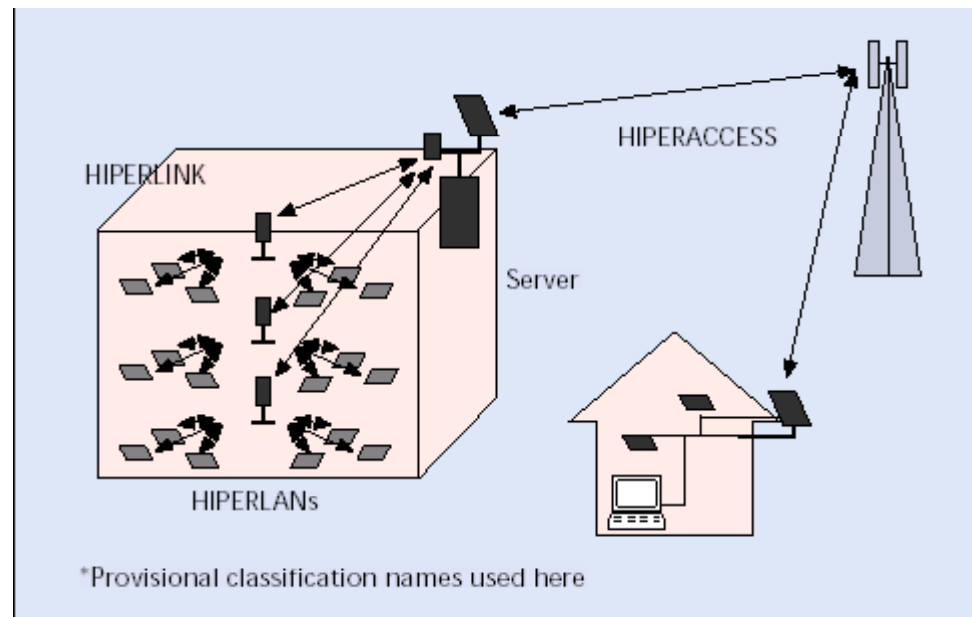

WiMAX Nomadic and Portable



802.16e PC Card

Non Line of Sight
Point to Multi-point

802.16

Line of Sight
BACKHAUL

802.16

Laptop Connected
Through 802.16

SEEKS BEST
CONNECTION

2 to 3 Kilometers Away

Telco Core
Network or
Private (Fiber)
Network

INTERNET
BACKBONE

Ref: Margaret LaBrecque , “Enabling Deployments through Standards and Certification,”
WiMax, 2003

Wireless & Multimedia Network Laboratory™



**National Central University
&
Hughes Network Systems
LMDS Demo Briefing**

November 1999

Campus Network

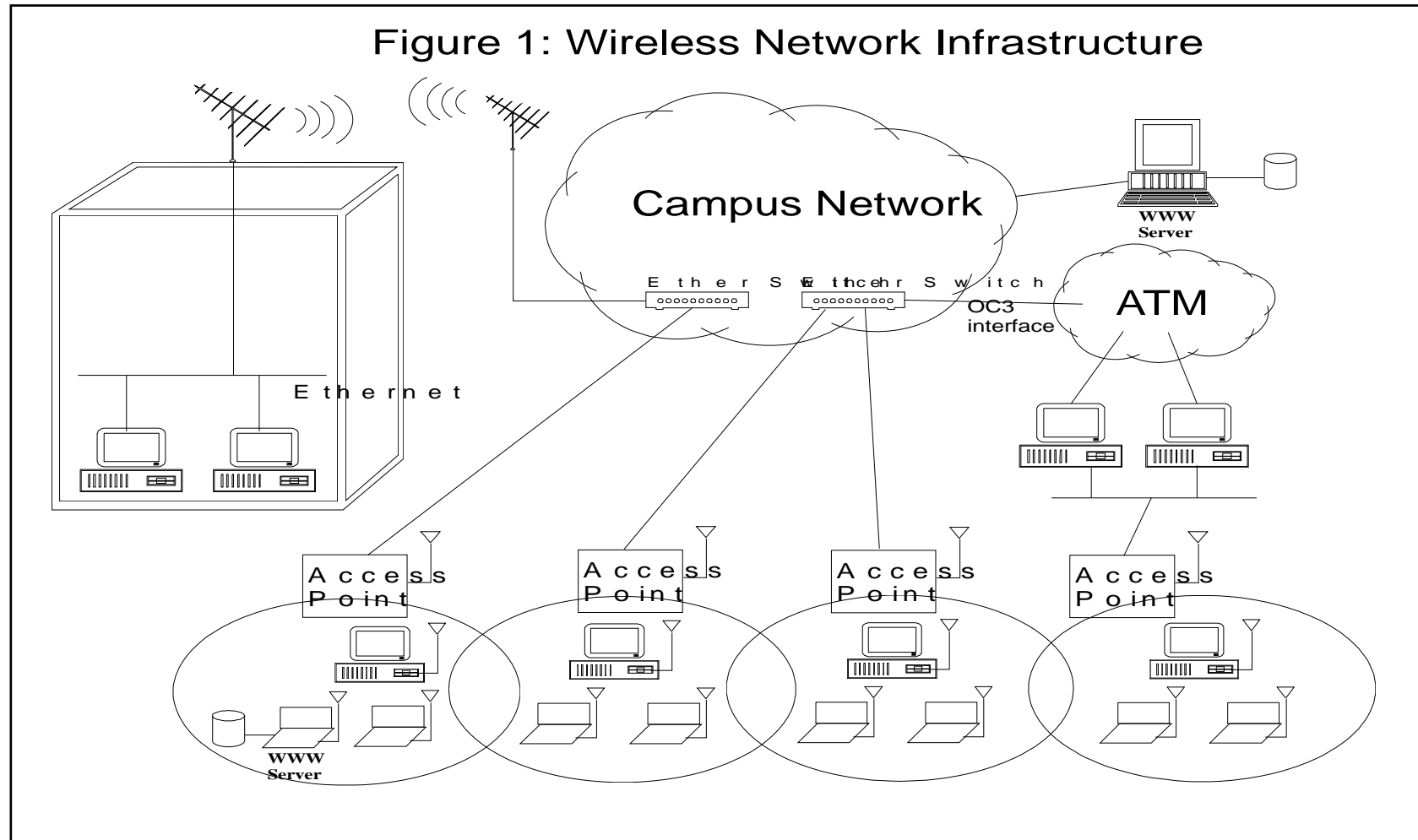

LMDS NCU Test-bench

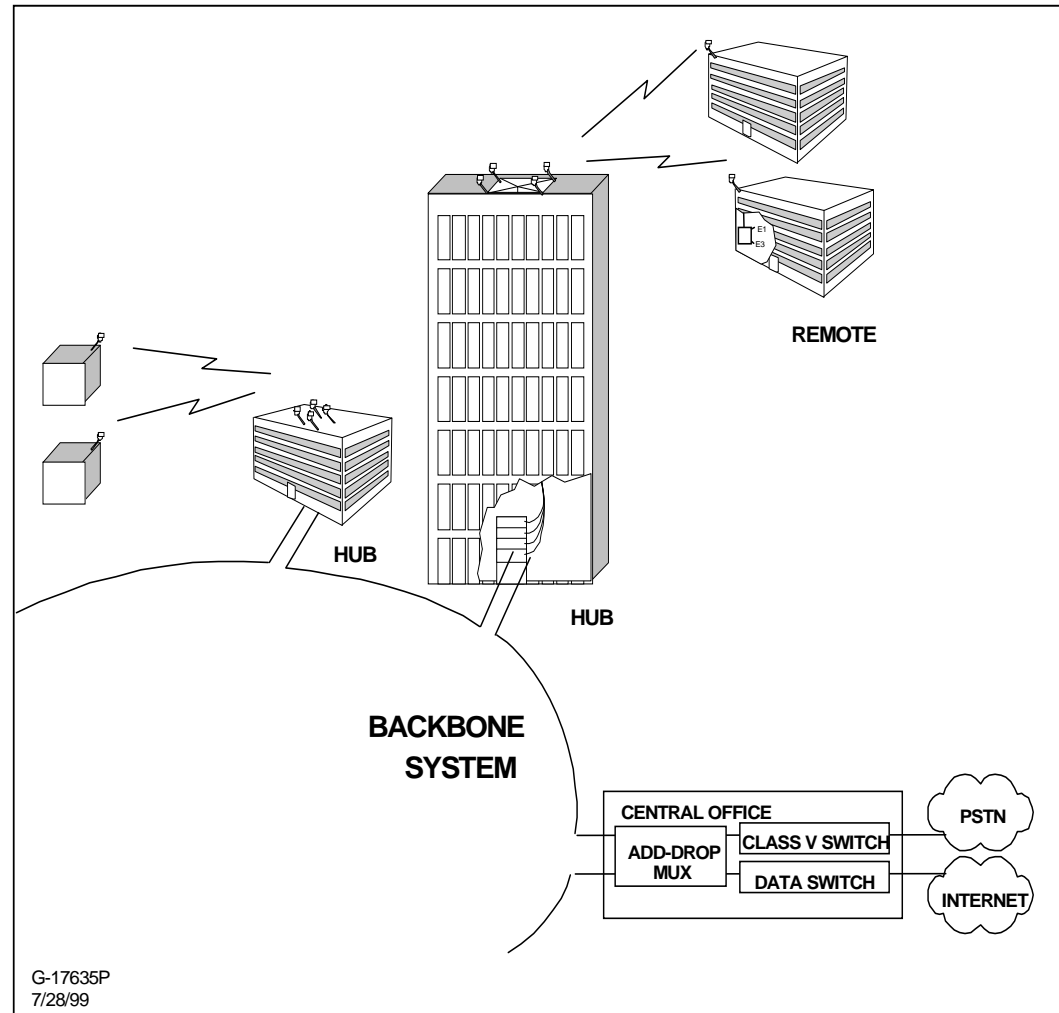

Architecture of the Demo

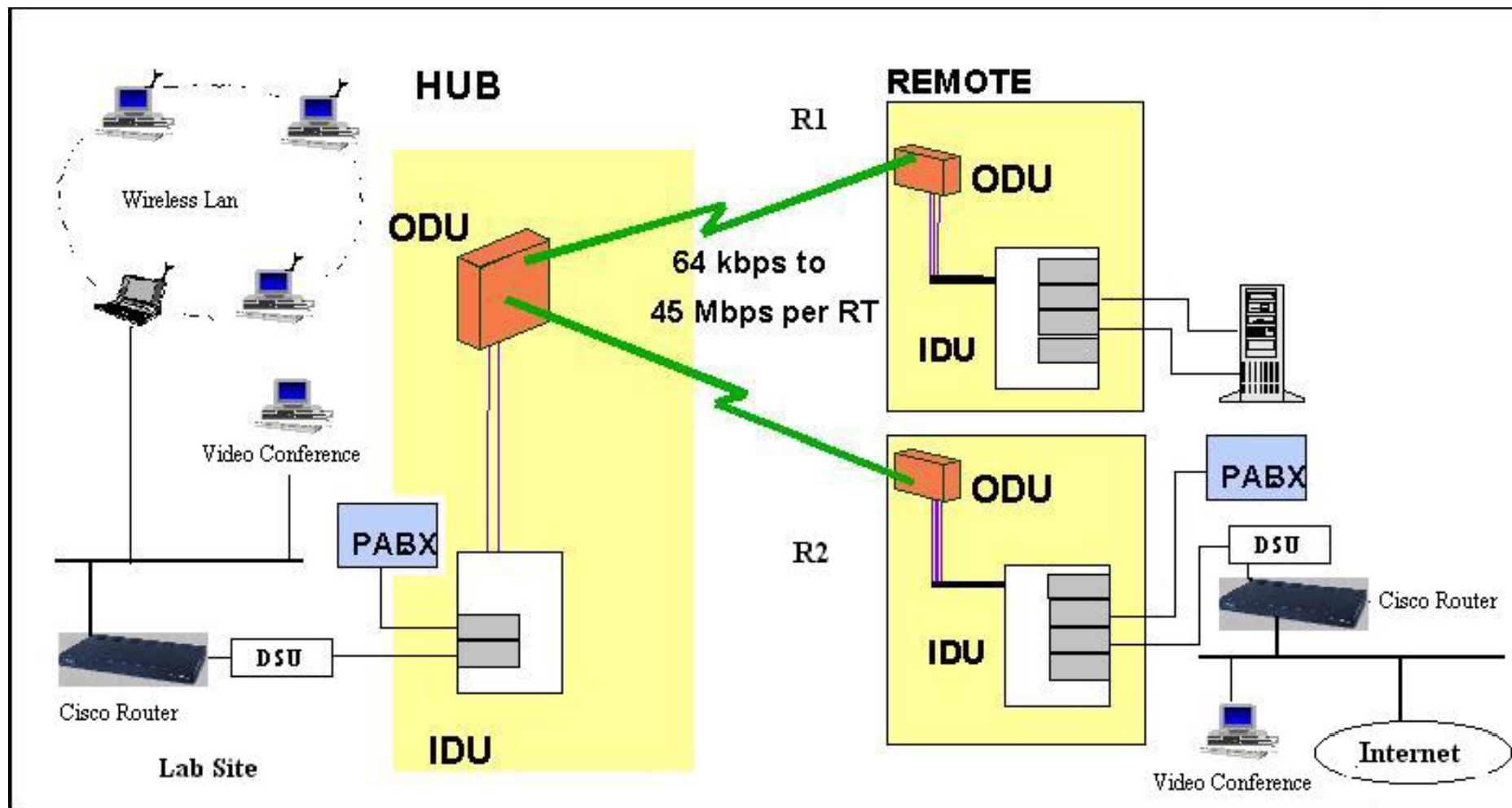

National Central University Demo Layout

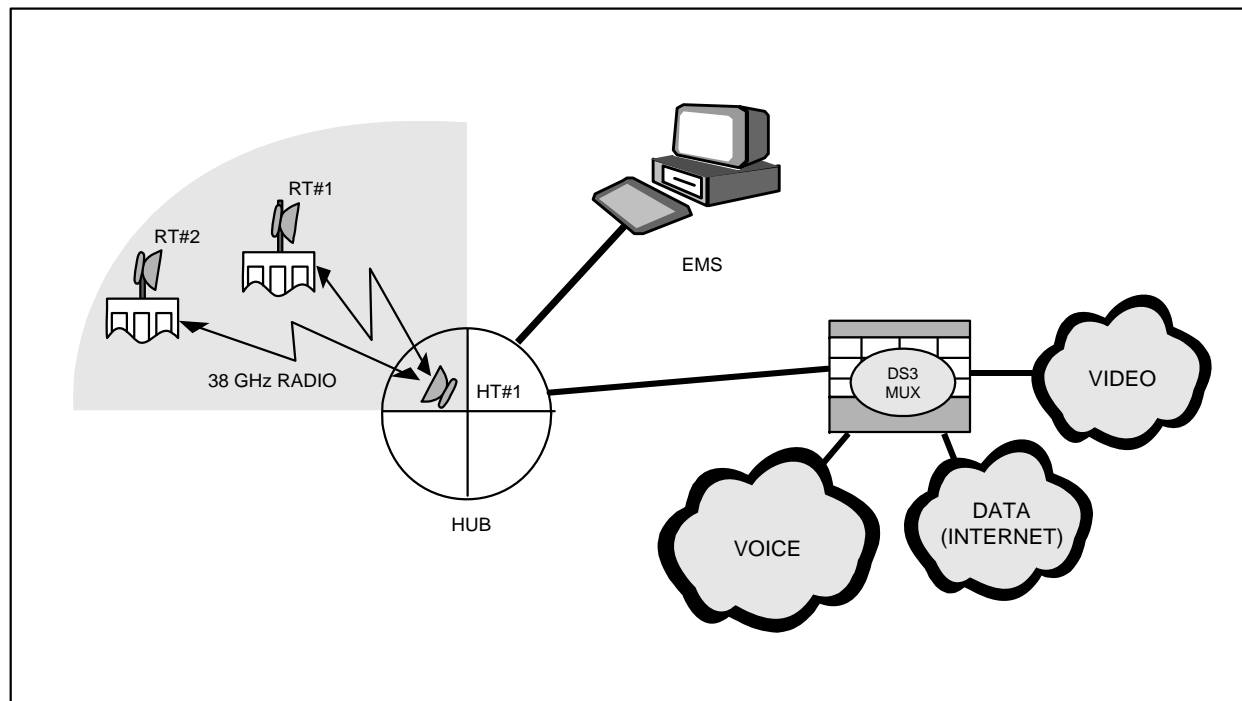

G-17833P 8/19/99

Step.1 LMDS Architecture

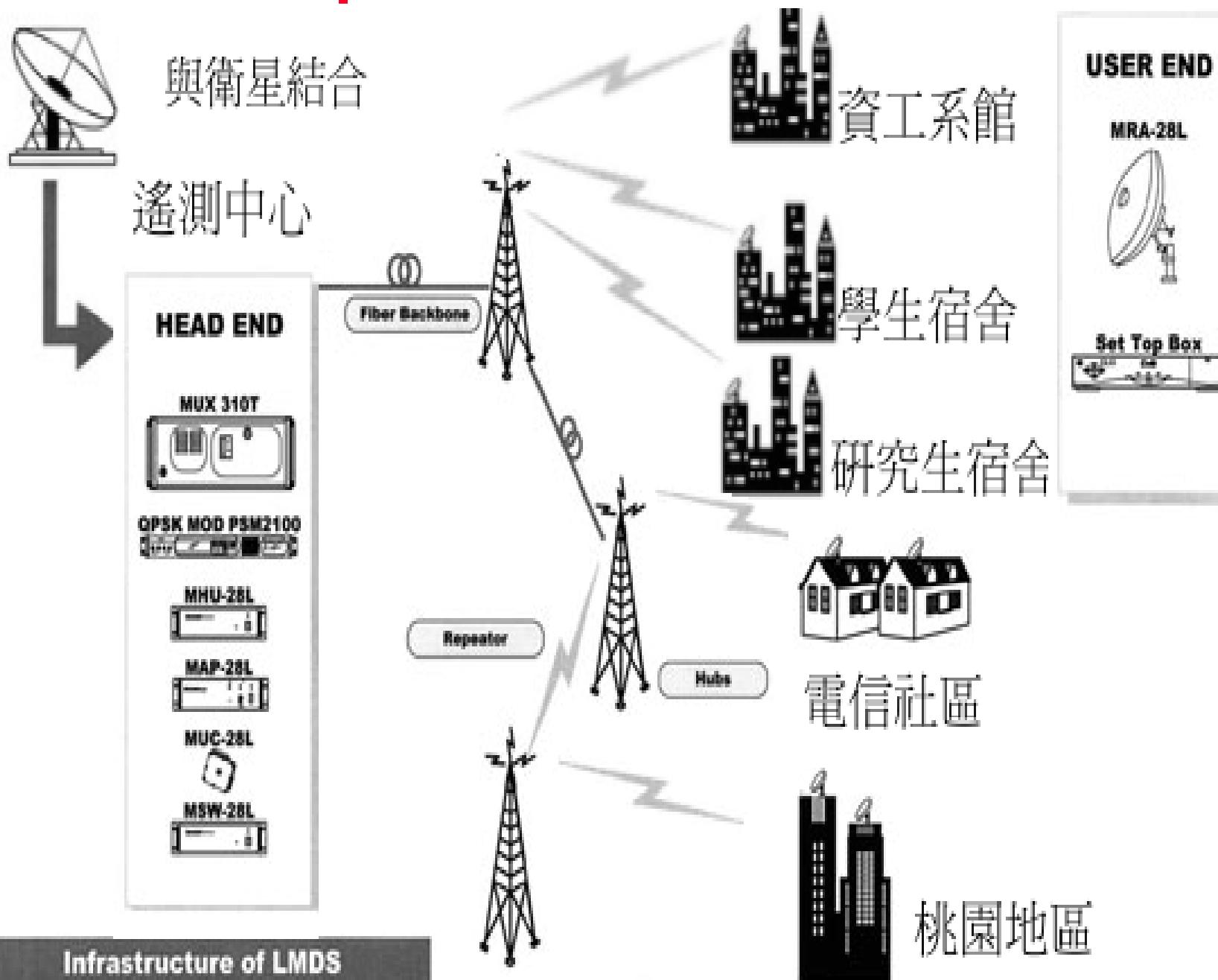

Infrastructure of LMDS

WiMAX Consumer Last Mile

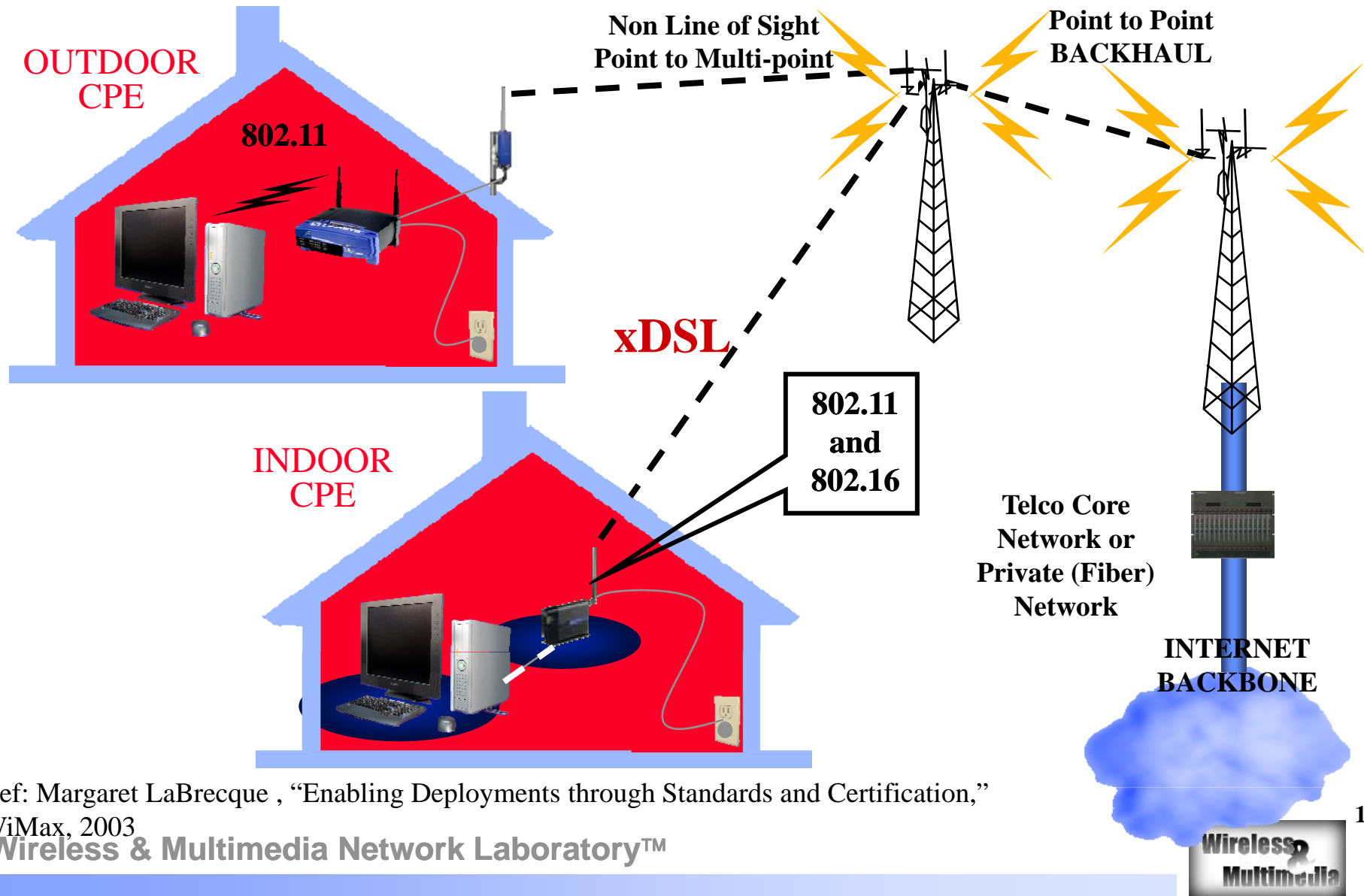

Ref: Margaret LaBrecque , "Enabling Deployments through Standards and Certification,"

WiMax, 2003

Wireless & Multimedia Network Laboratory™

IEEE 802.11 Configurations - Independent

- ◆ Independent
 - one Basic Service Set - BSS
 - Ad Hoc network
 - direct communication
 - limited coverage area

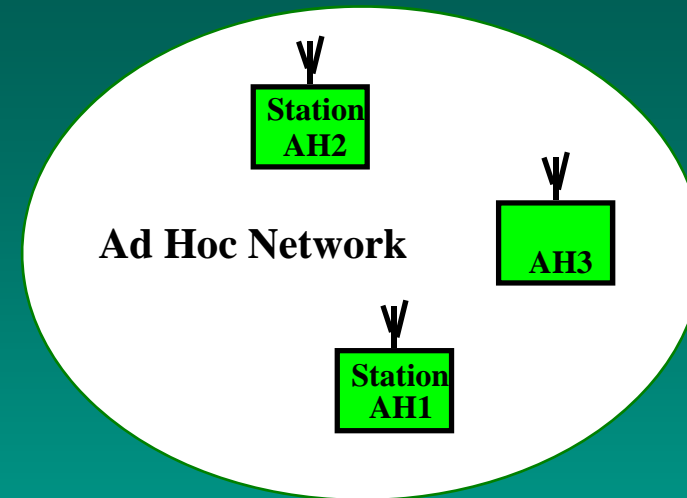

Topology of a Wireless LAN

- ◆ 進接(Access)應用: 使用者與網路的连接

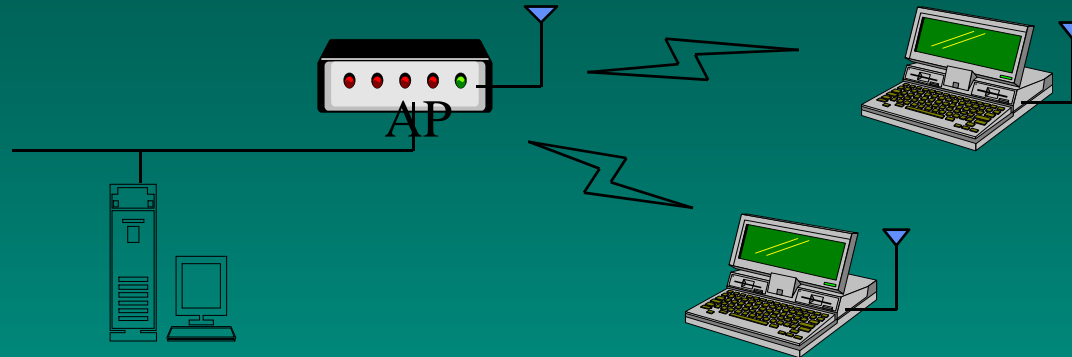

- ◆ 中繼(Trunk)或骨幹(Backbone)應用: 網路與網路之间的连接. 例如,大樓與大樓之间的通訊, 或是遠方網路的连接.

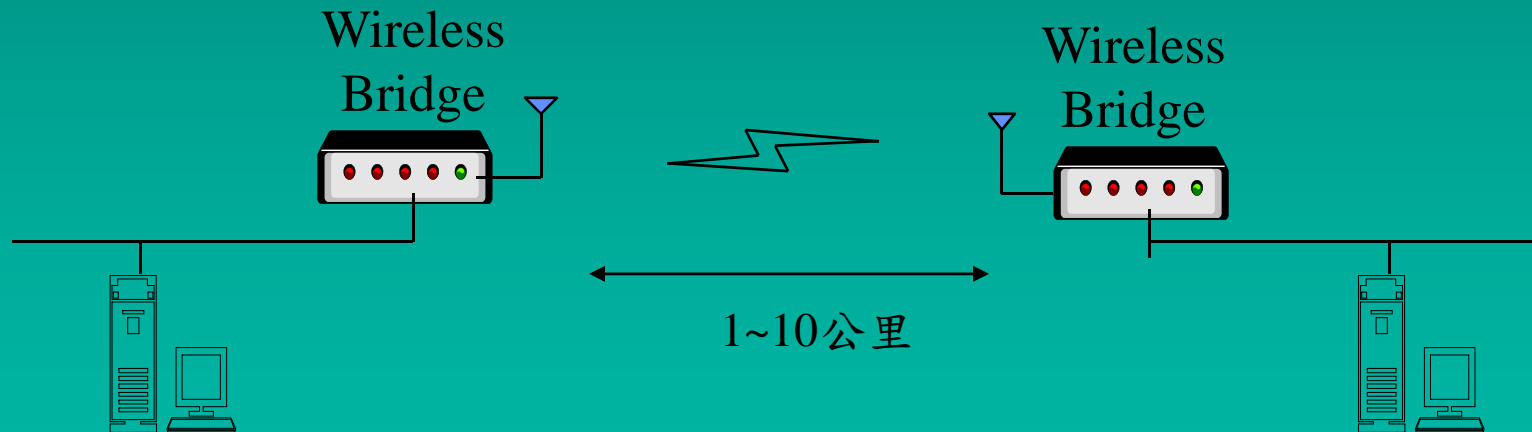

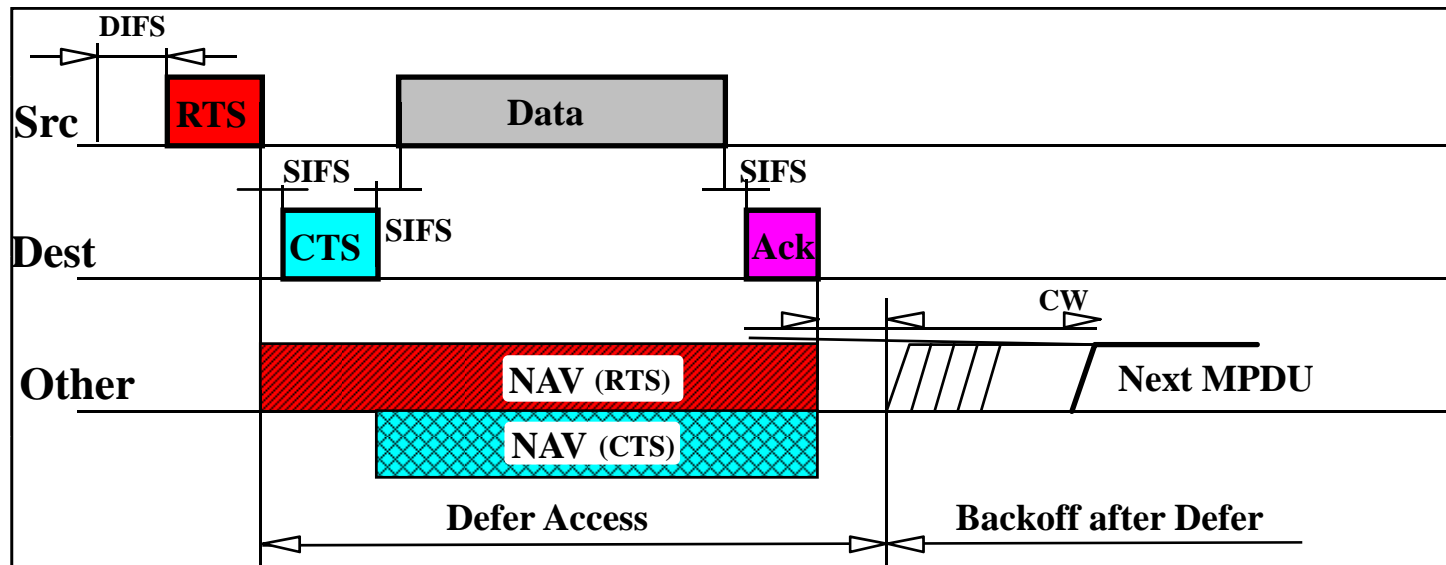

- ***Duration*** field in RTS and CTS frames distribute ***Medium Reservation*** information which is stored in a ***Network Allocation Vector (NAV)***.
- Defer on either NAV or "CCA" indicating ***Medium Busy***.
- Use of RTS / CTS is optional but must be implemented.

QoS Challenge in Mesh Client Networks [12]

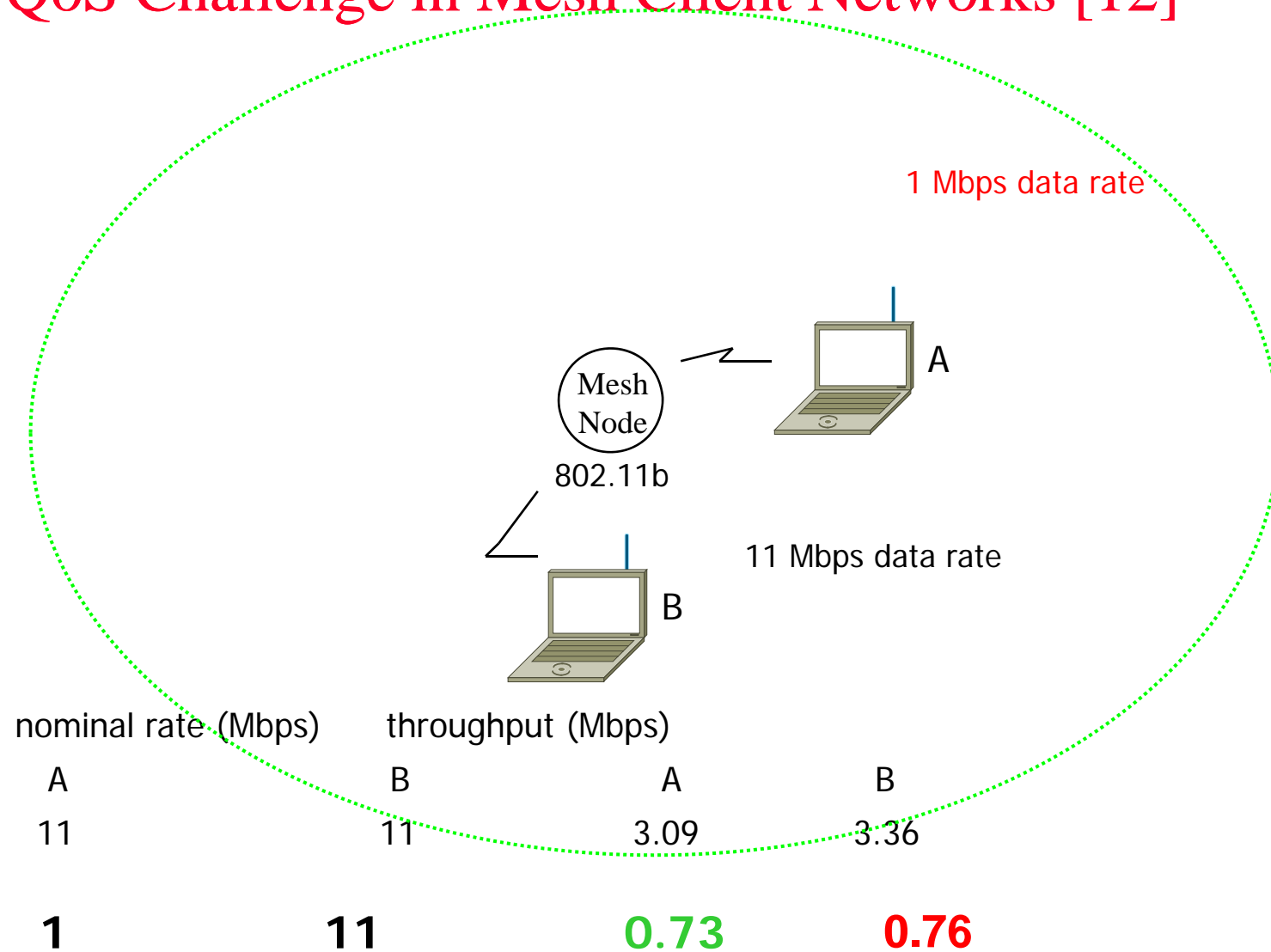

IP integration

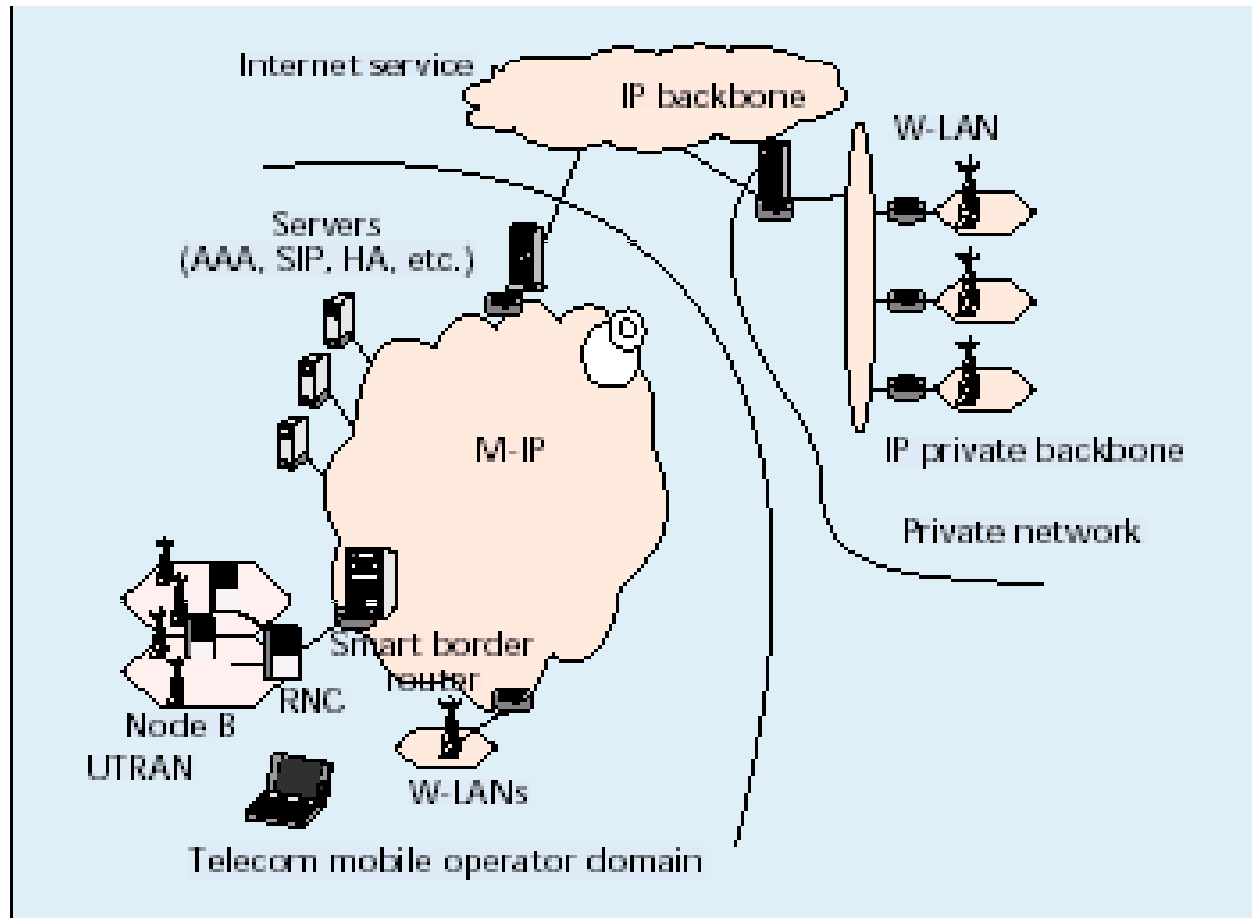

WiMedia Solutions – Simple Usage



Capacity and Mobility

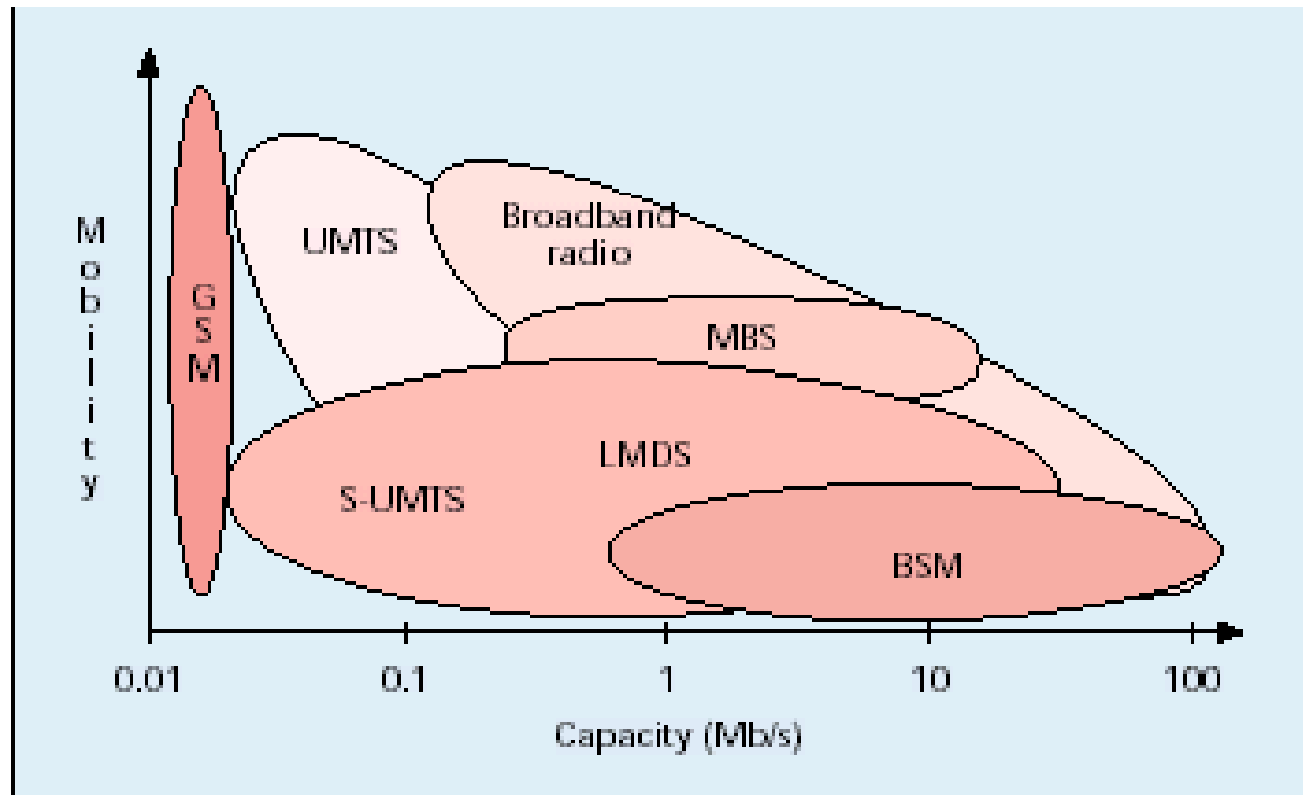

地球村的建立

衛星本體

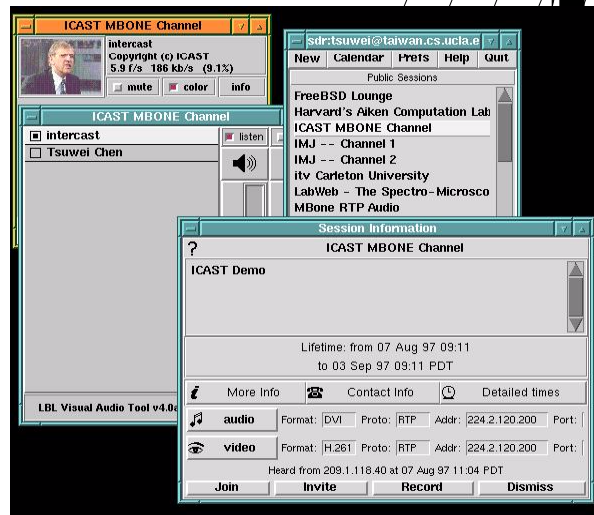
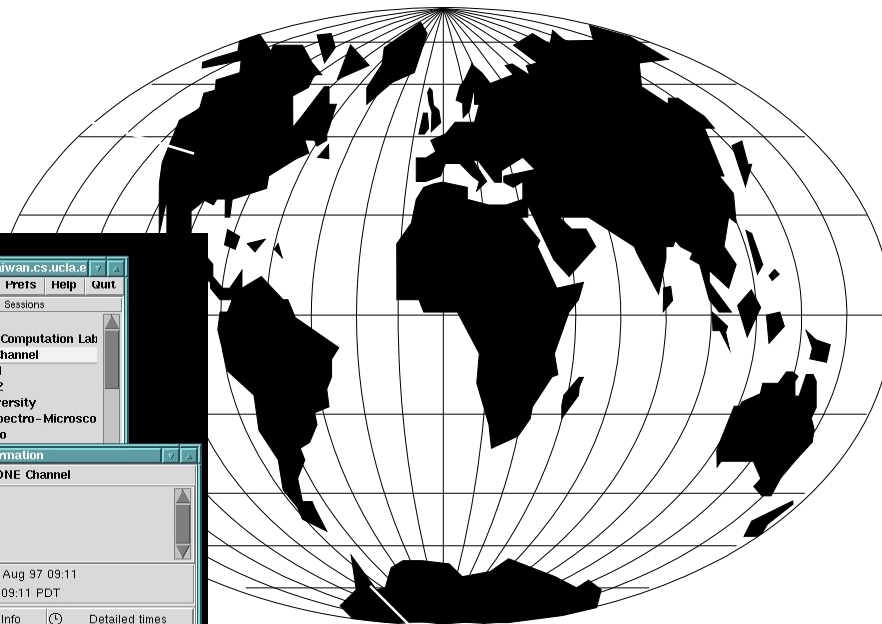
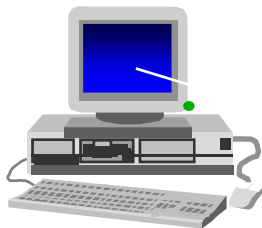
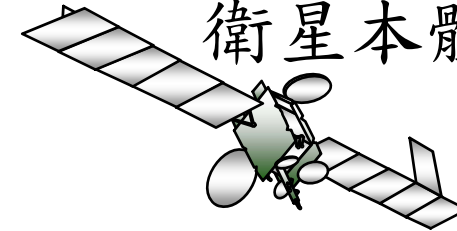

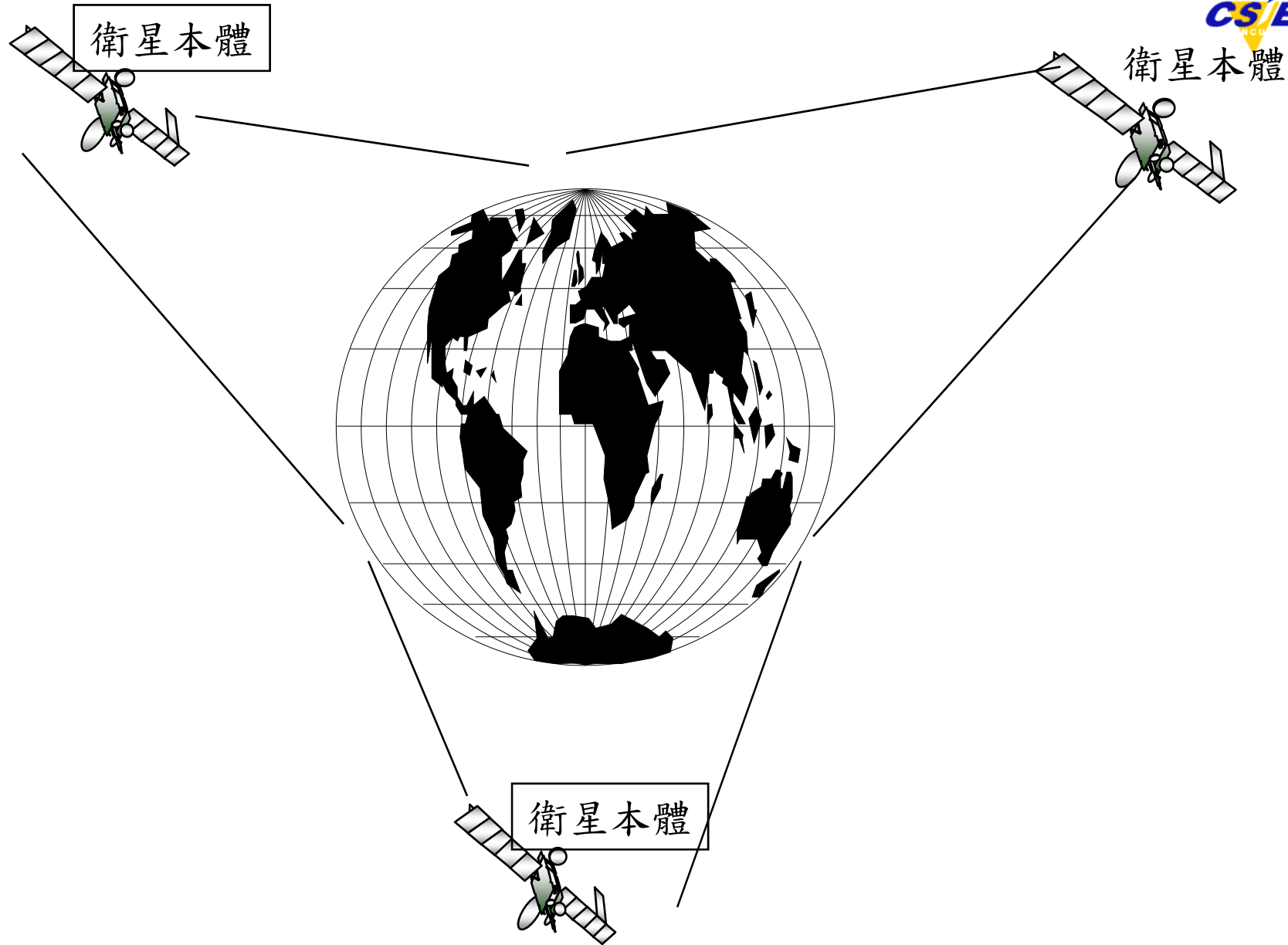

Sky of Satellites

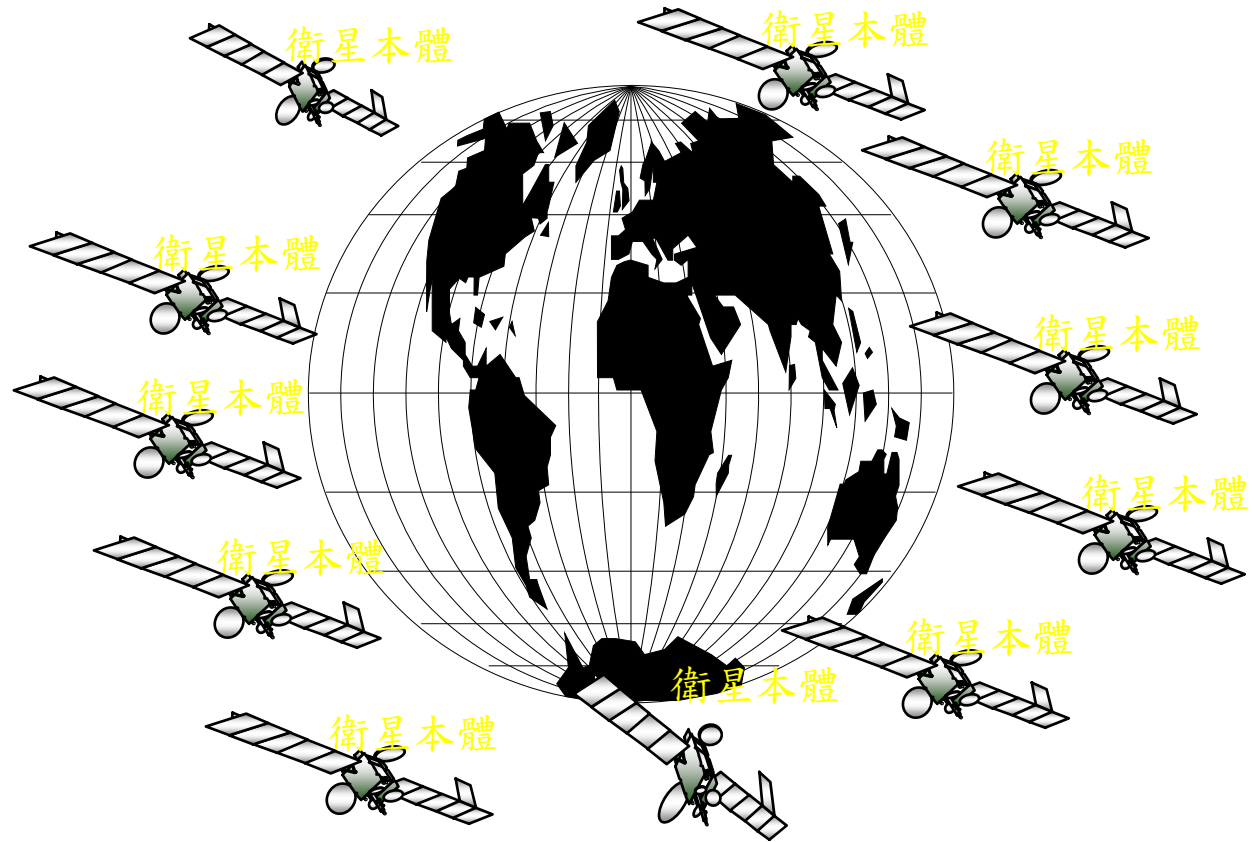

DirecPC Satellite Experiments

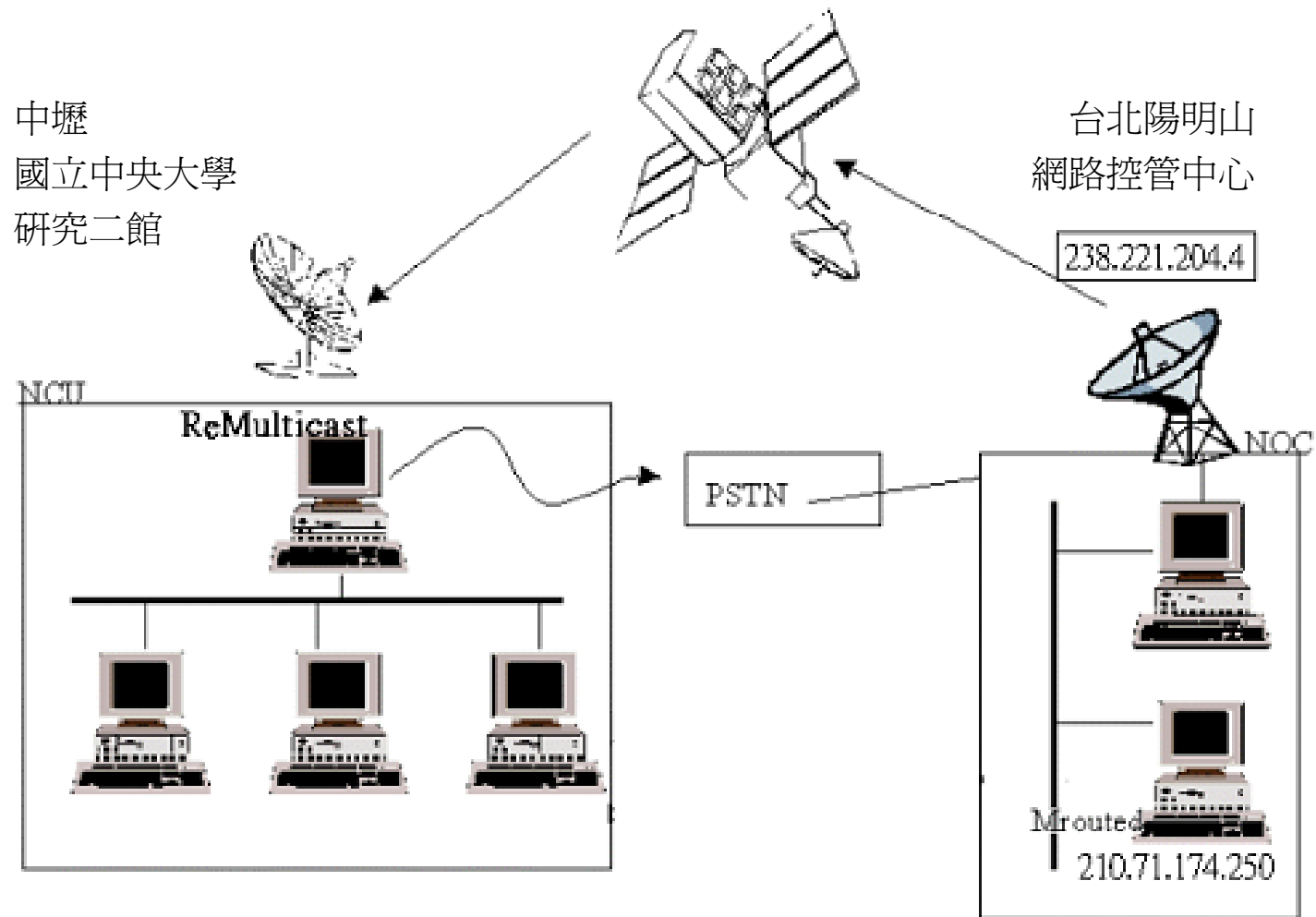

Ubiquitous Access

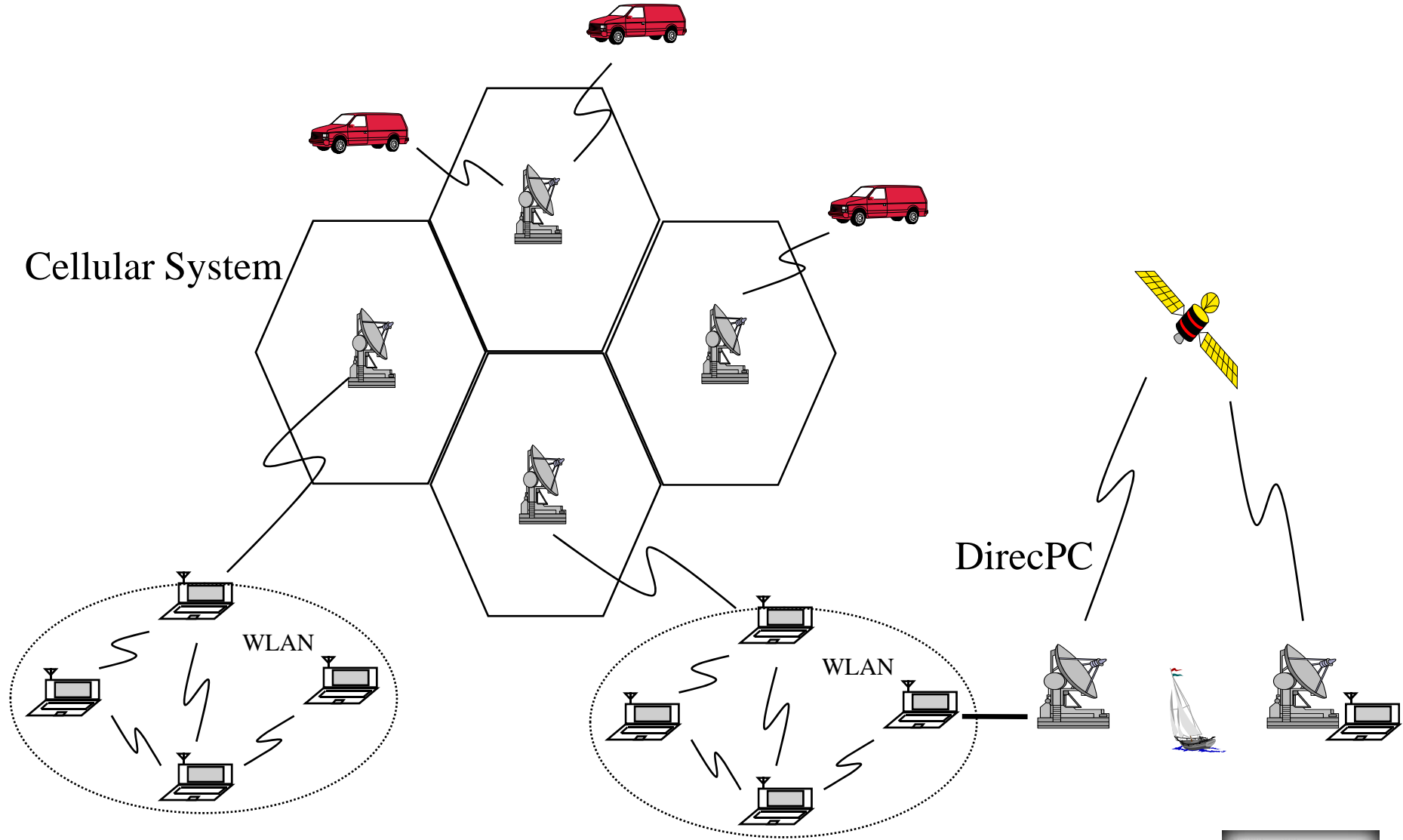

“Anytime Anywhere ” Information System

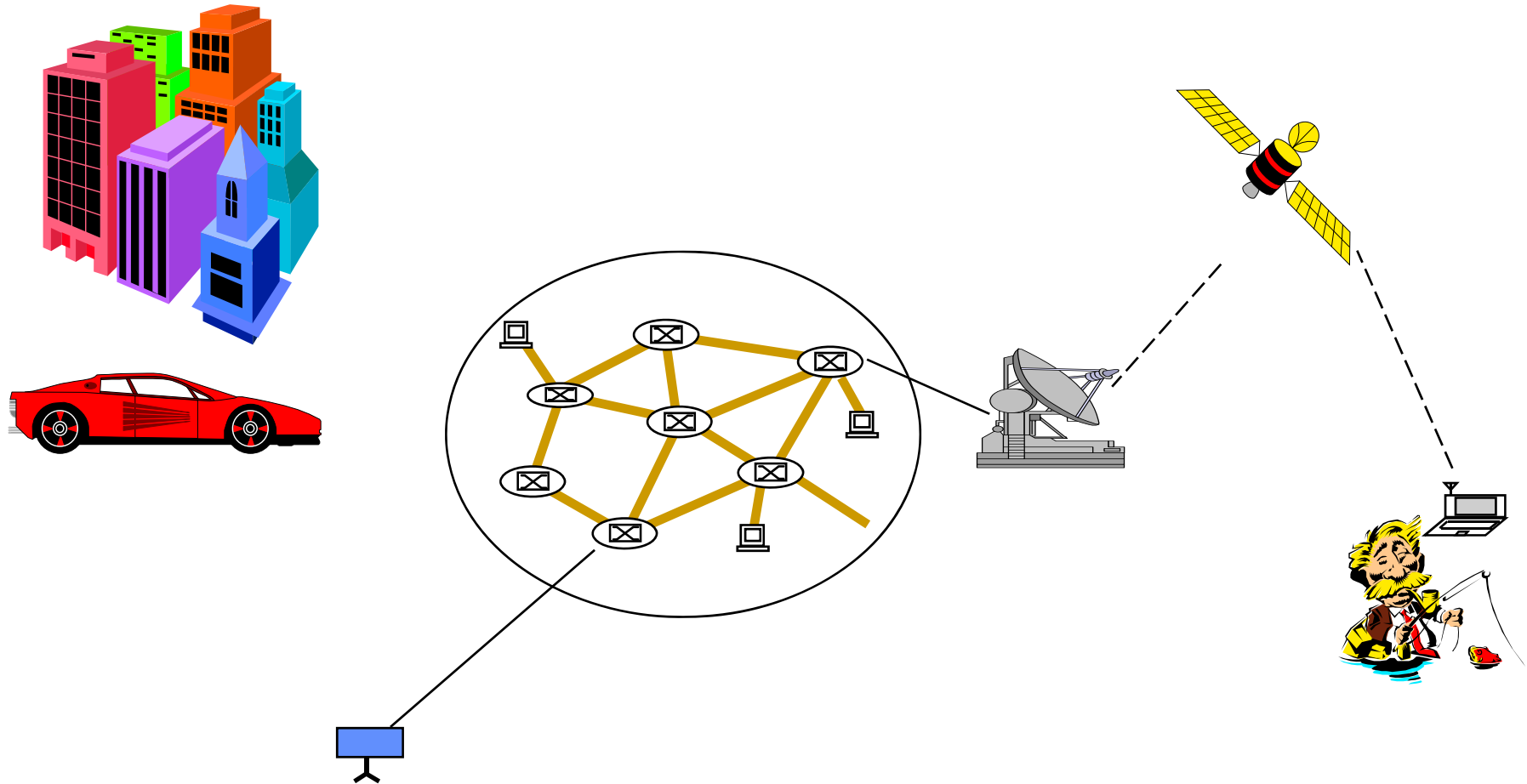

Fundamental Issues



Three System Components

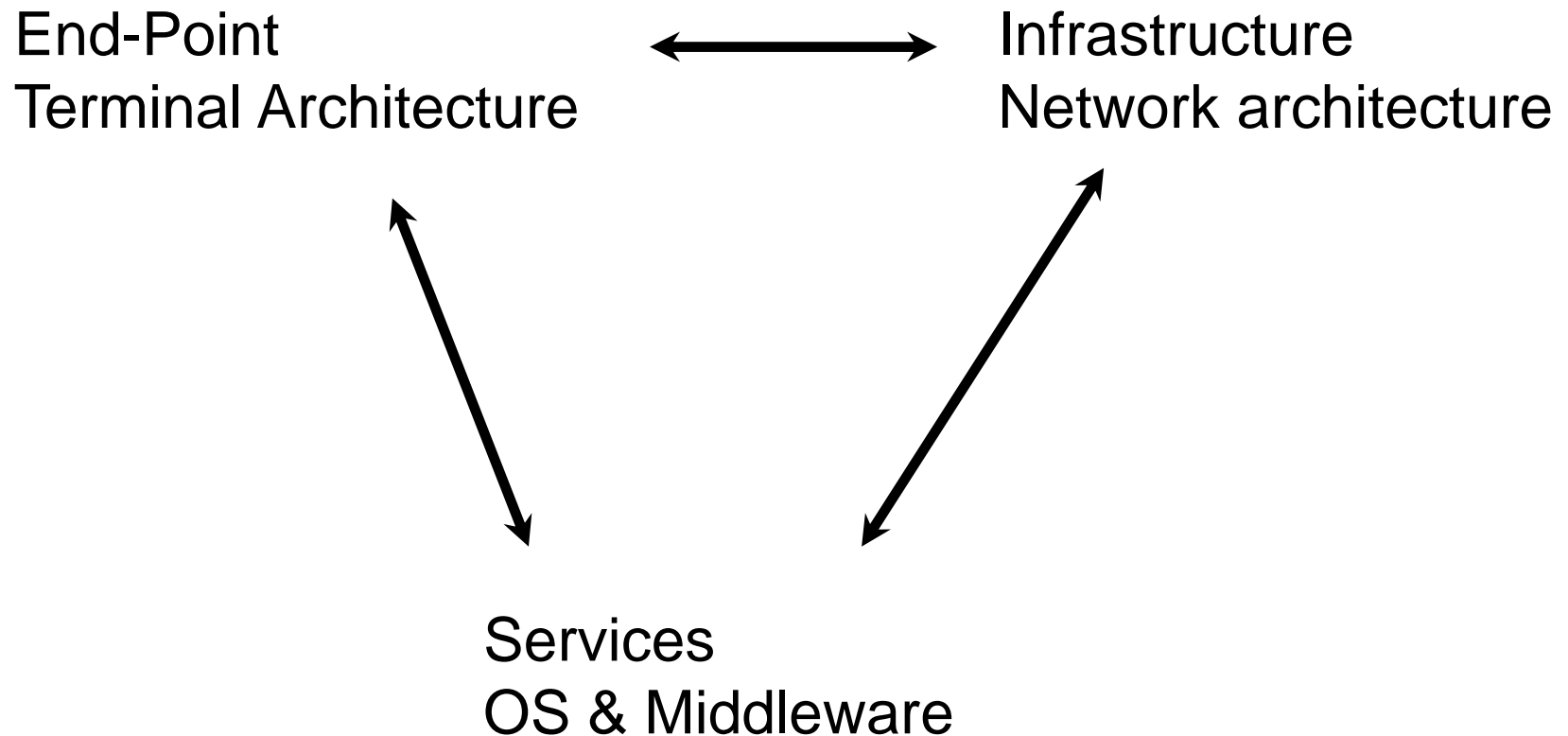

Personal area network



Connect devices to internet on the mobile infrastructure world wide

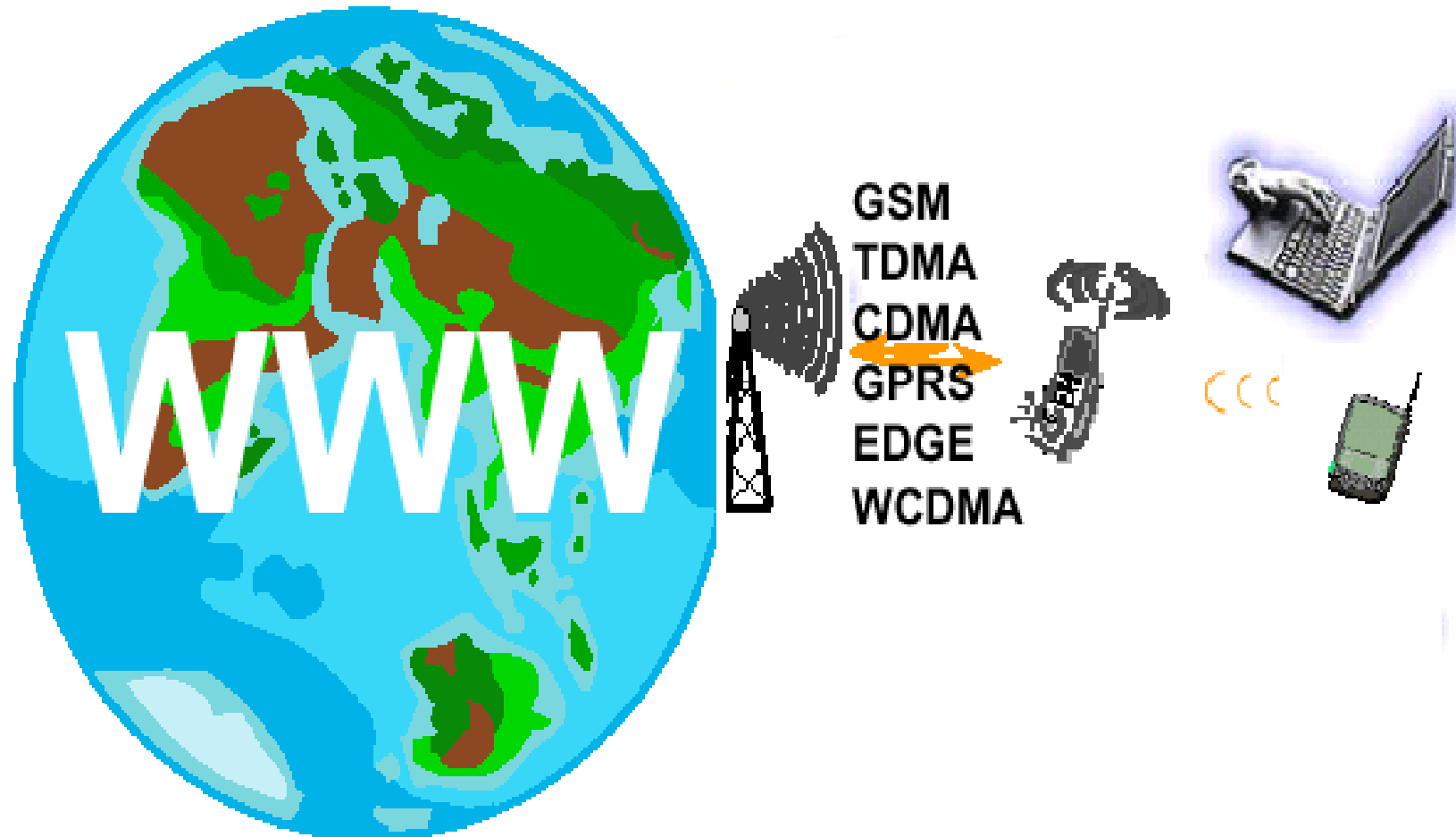

QoS and Multimedia Traffic Support

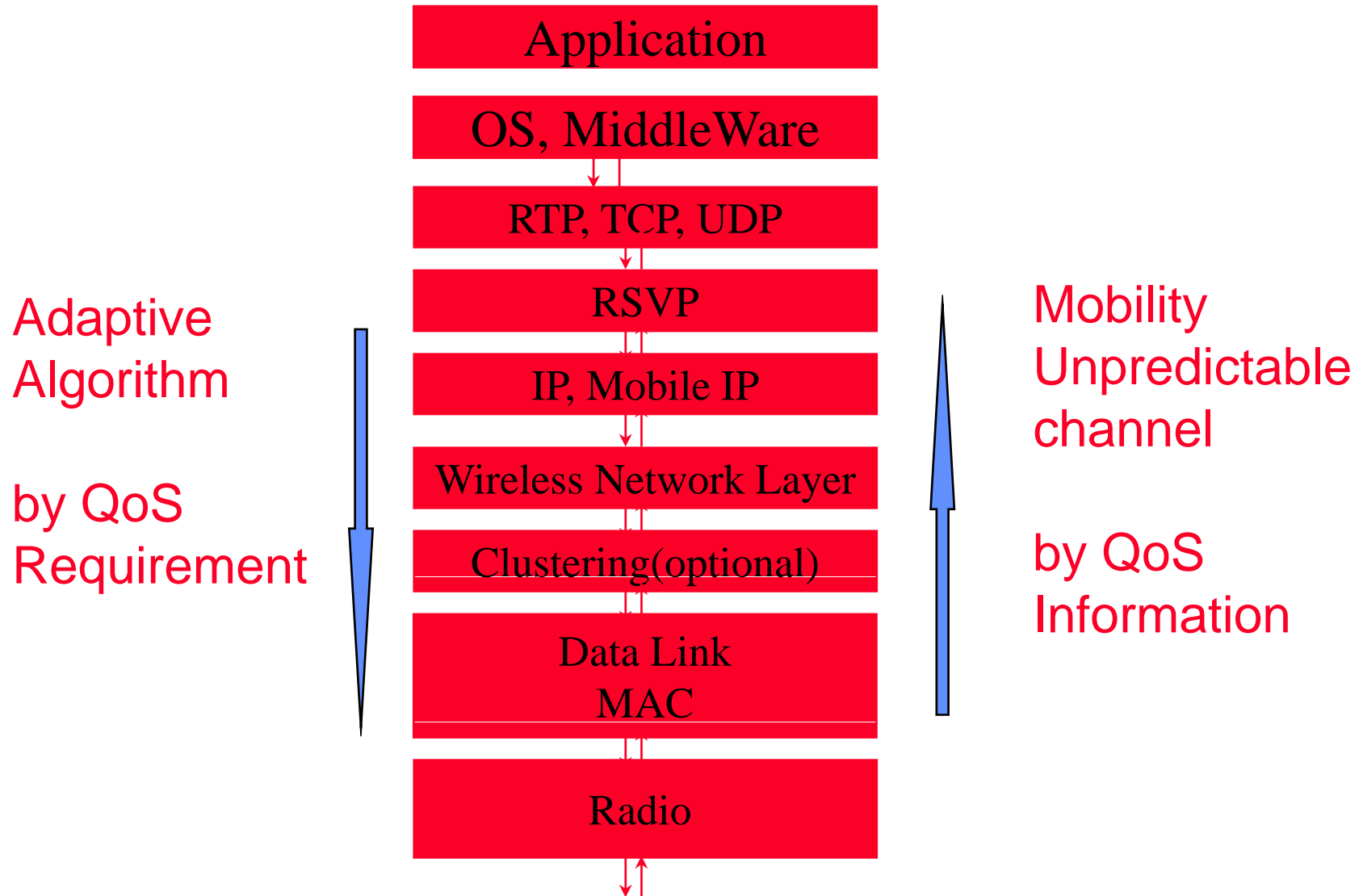

QoS and Multimedia Traffic Support

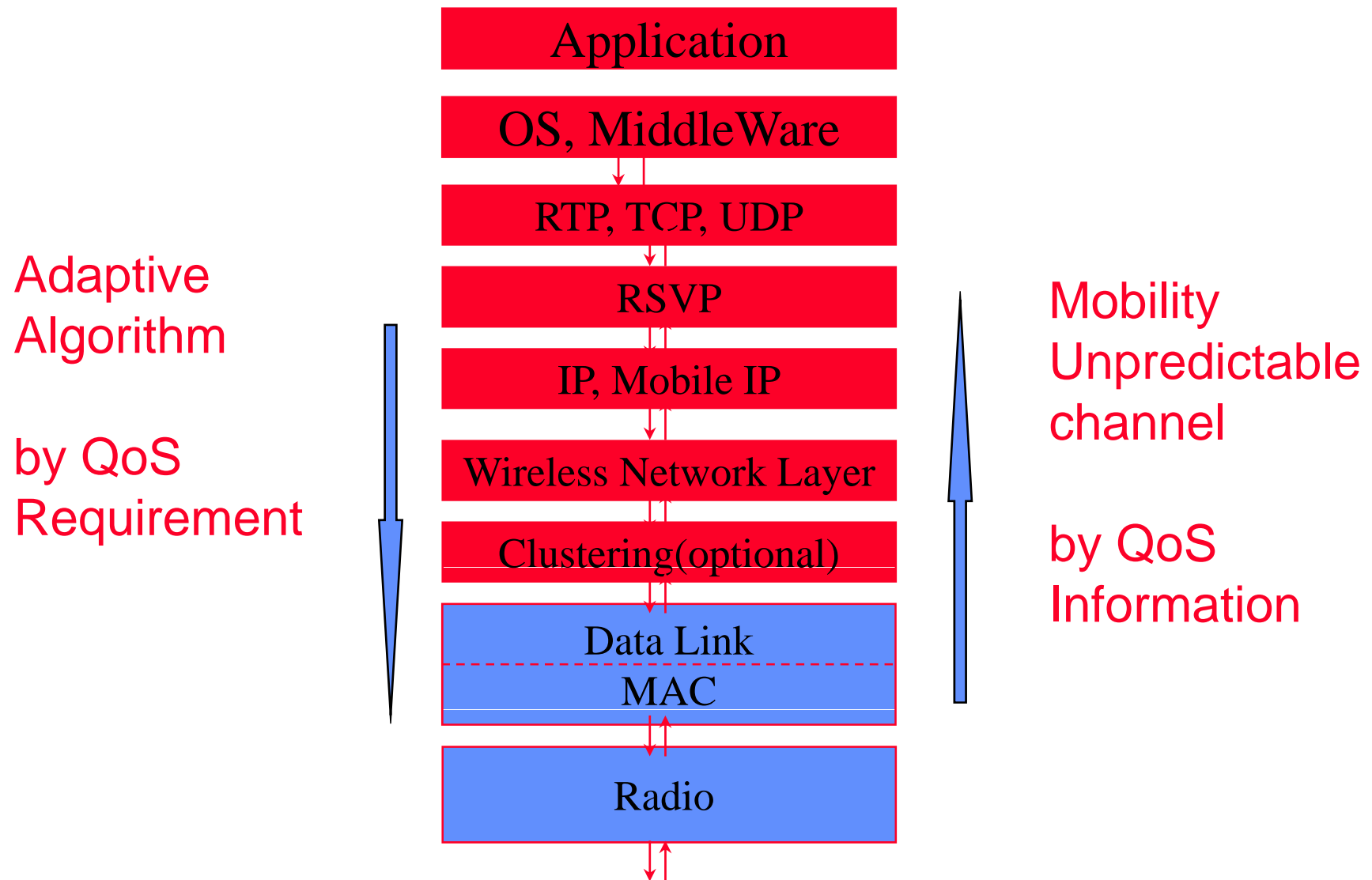

Channel Propagation and Fading

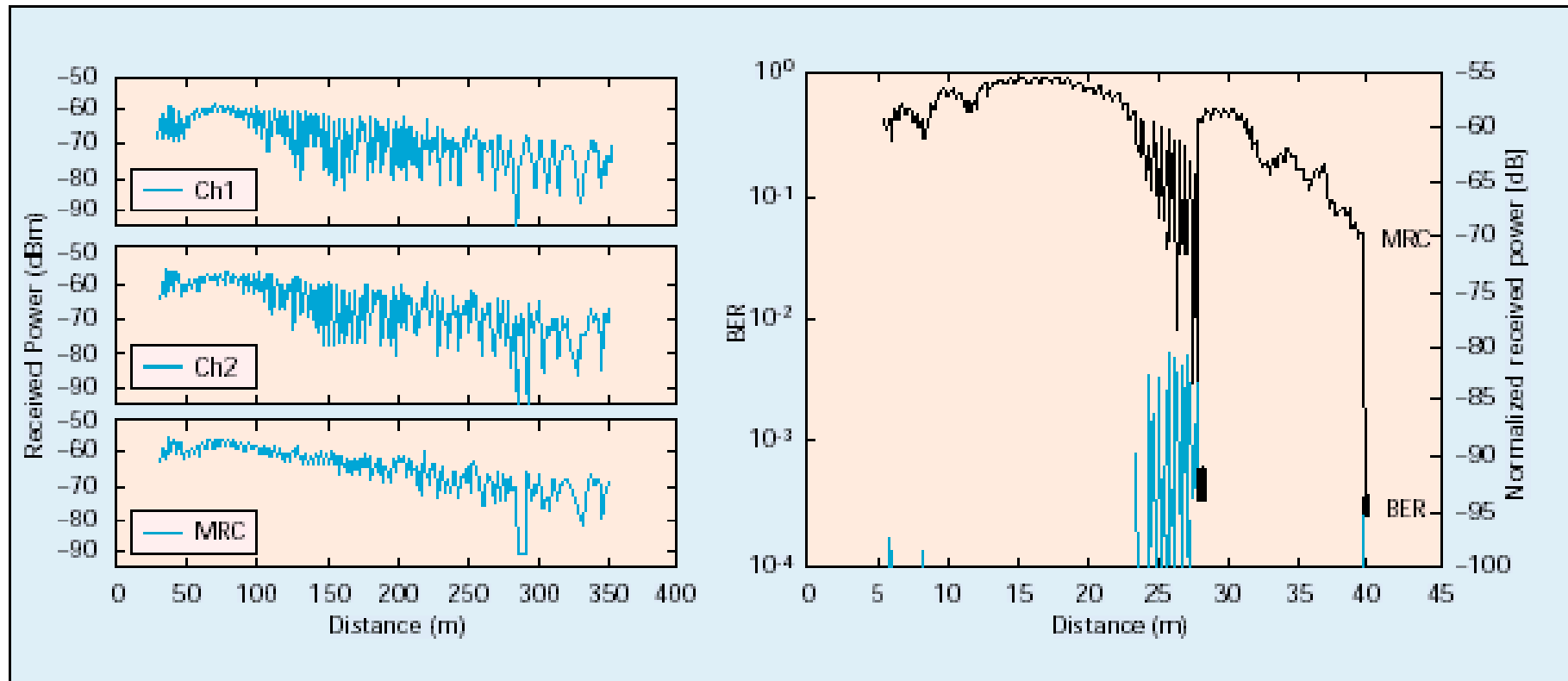

■ Figure 4. Received power as a function of distance: in a street (left), in a pavilion (right); BER and handover (right).

Intra-Domain Handoff

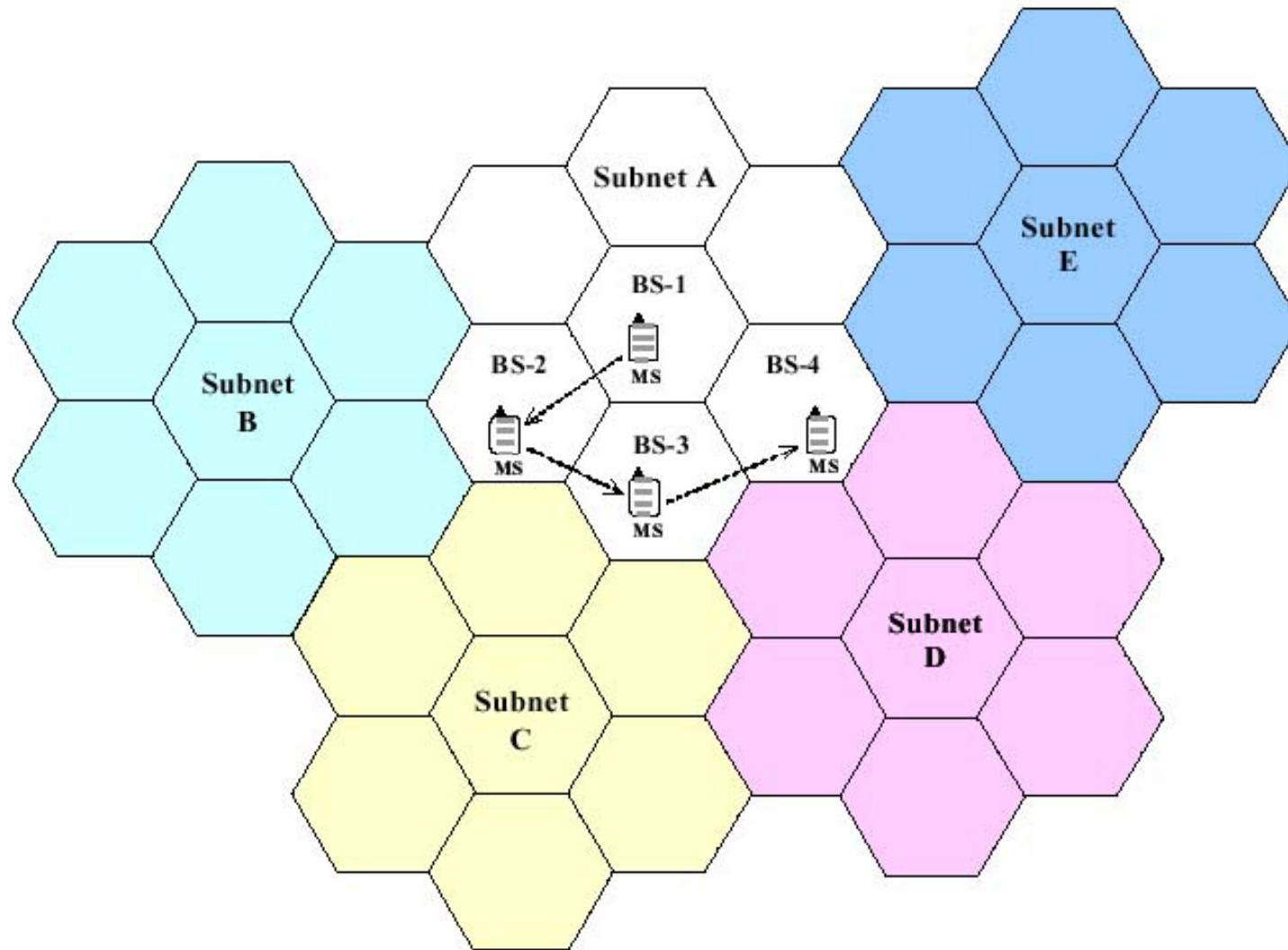

Resource Sharing

- ◆ Reservation Approaches
 - Centralized Control
 - token (round robin)
- ◆ Collision Approaches
 - fight for resource
 - distributed control

Through A Centralized Control

- ◆ TDMA, FDMA, CDMA

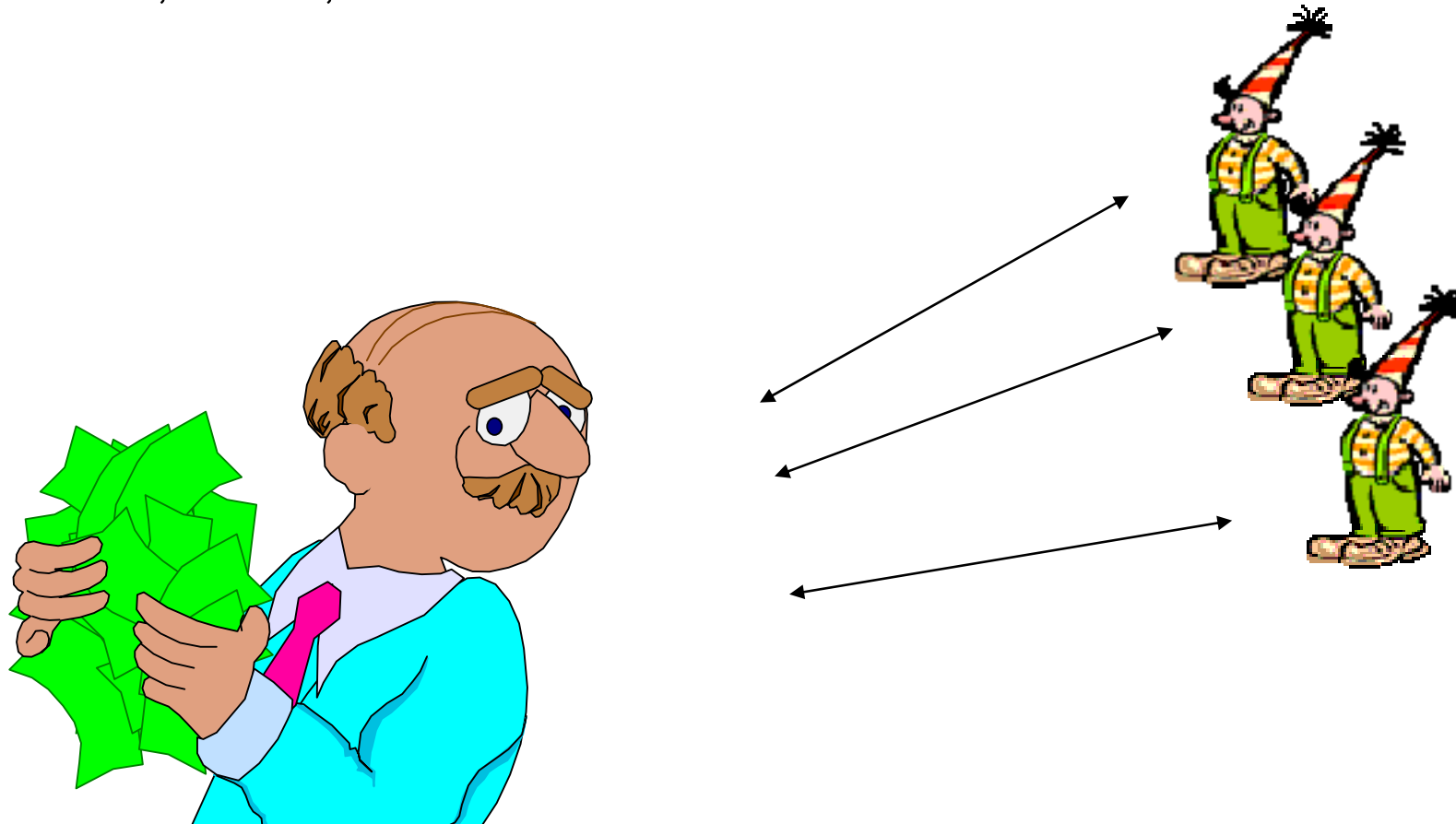

MACA/PR

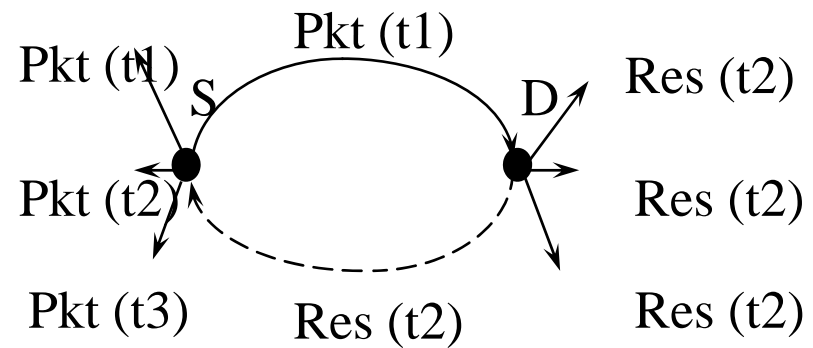
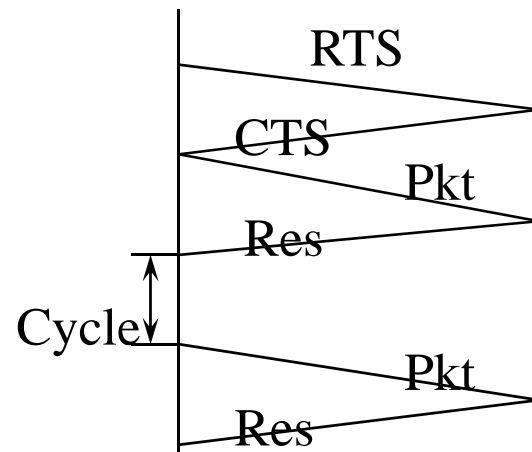

QoS and Multimedia Traffic Support

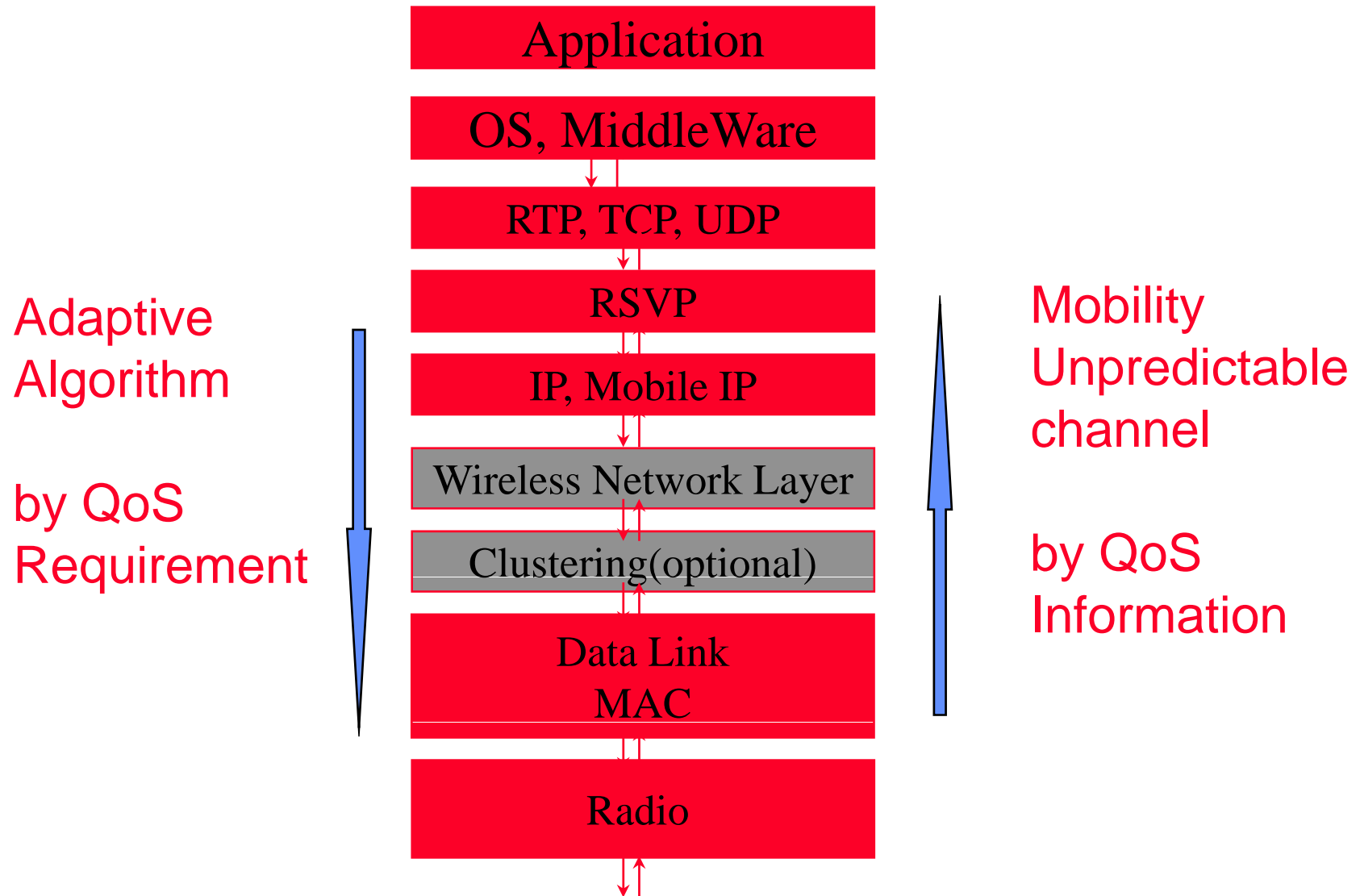

QoS and Multimedia Traffic Support

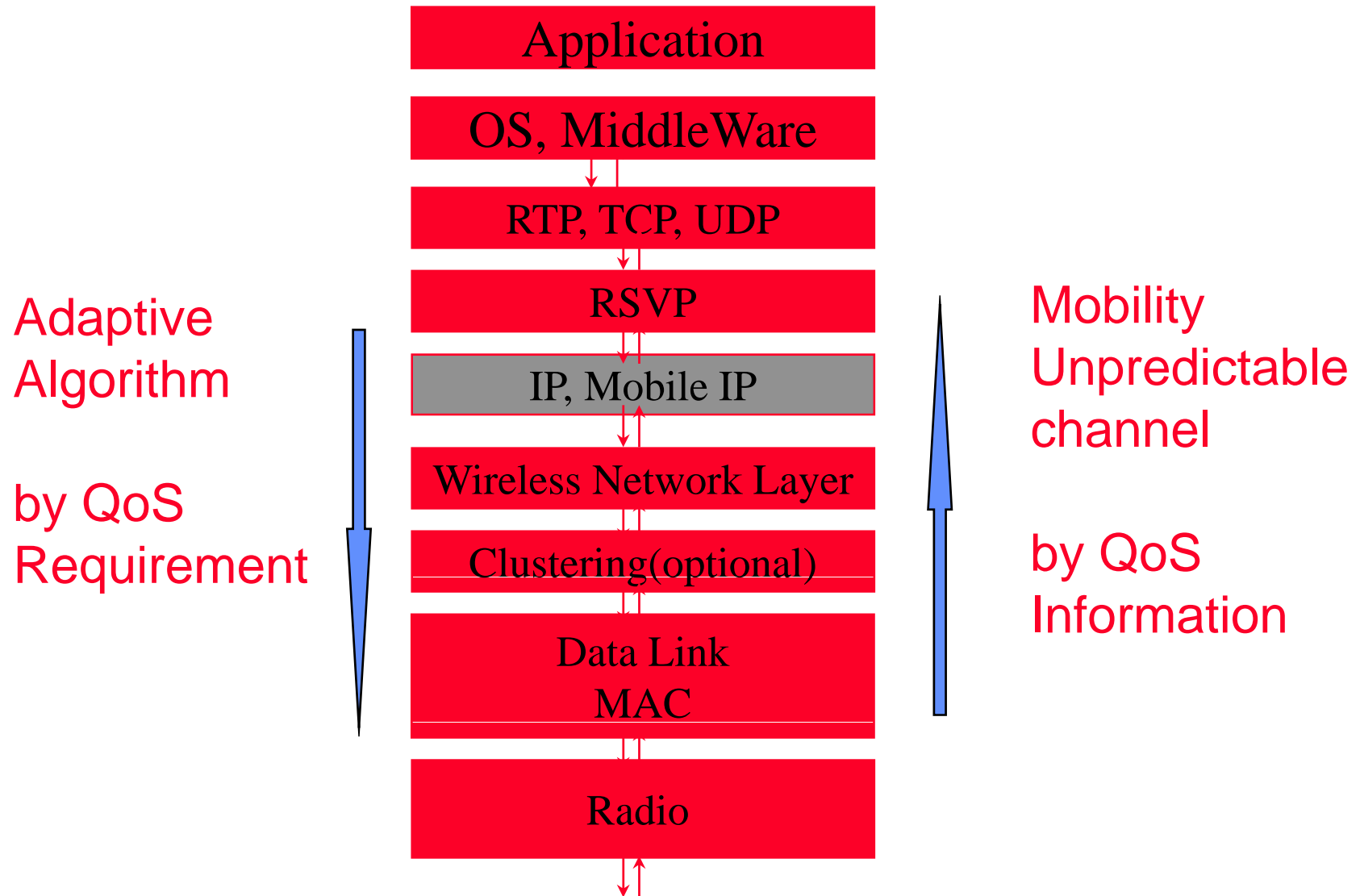

Internetworking, IP, Mobile

- ◆ Internetworking
 - roaming through different networks
 - supporting IP format
 - supporting IP portability



QoS and Multimedia Traffic Support

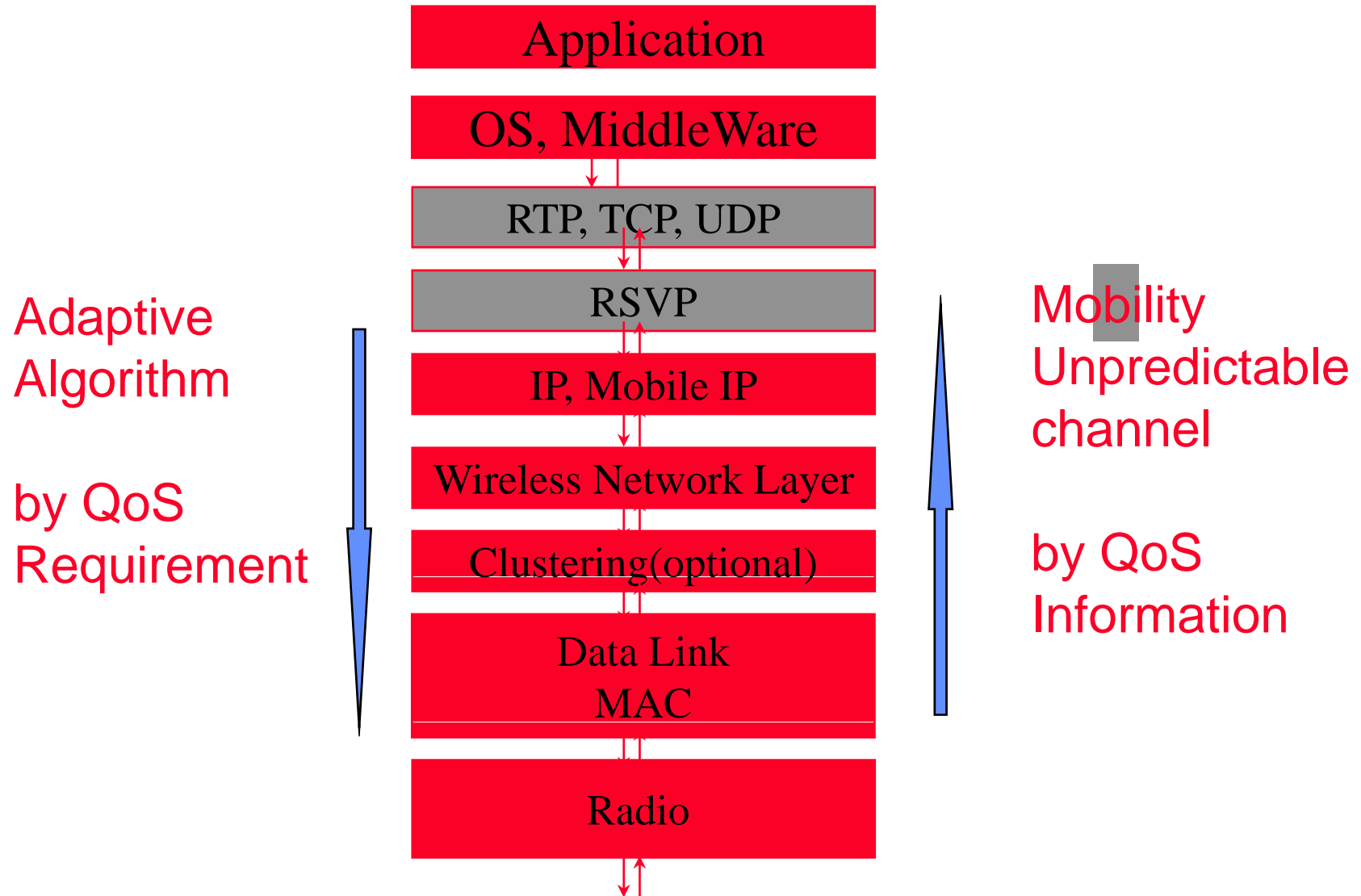

What problem does Multimedia Bring?

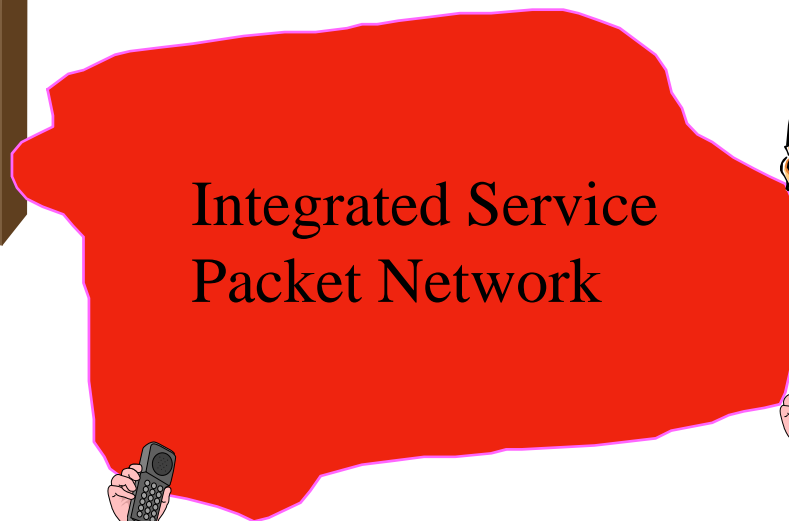
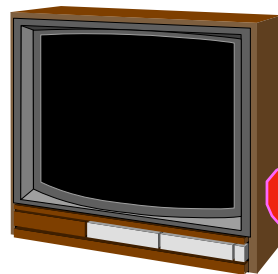
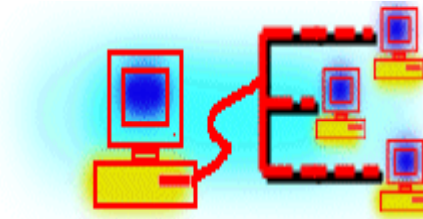
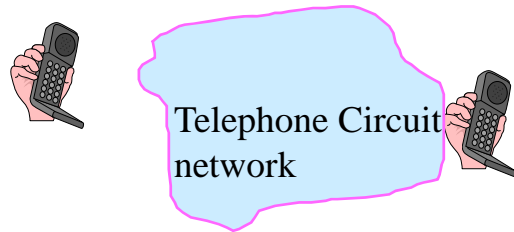

Emerging technologies:

1. "Datagrams" + "Flows" IPv6
2. "Virtual Circuits" (ATM)

5

System Configurations

- ◆ Ad hoc ~ Multi-hop
 - Wireless LAN
 - Blue-tooth
 - Packet Radio
 - WAMIS
- ◆ Cellular ~ GSM, WAP, GPRS, 3G
- ◆ Satellite ~ LEO, GEO

Ad Hoc Wireless Network

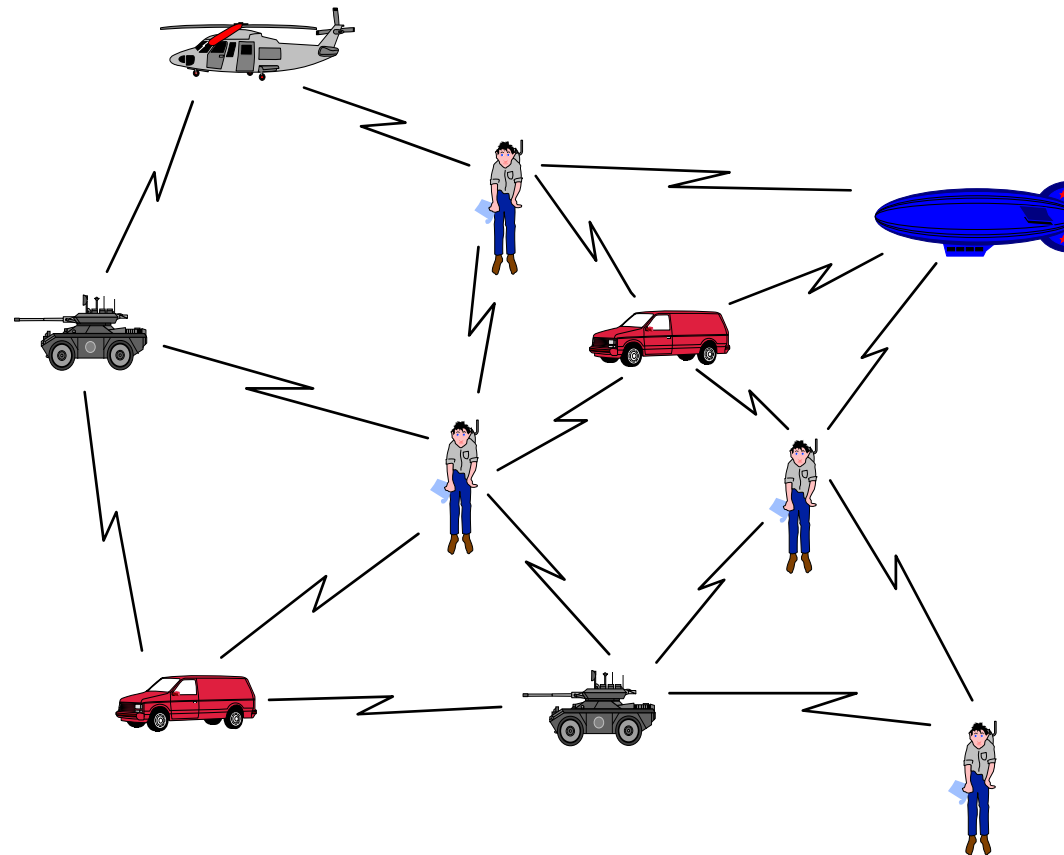

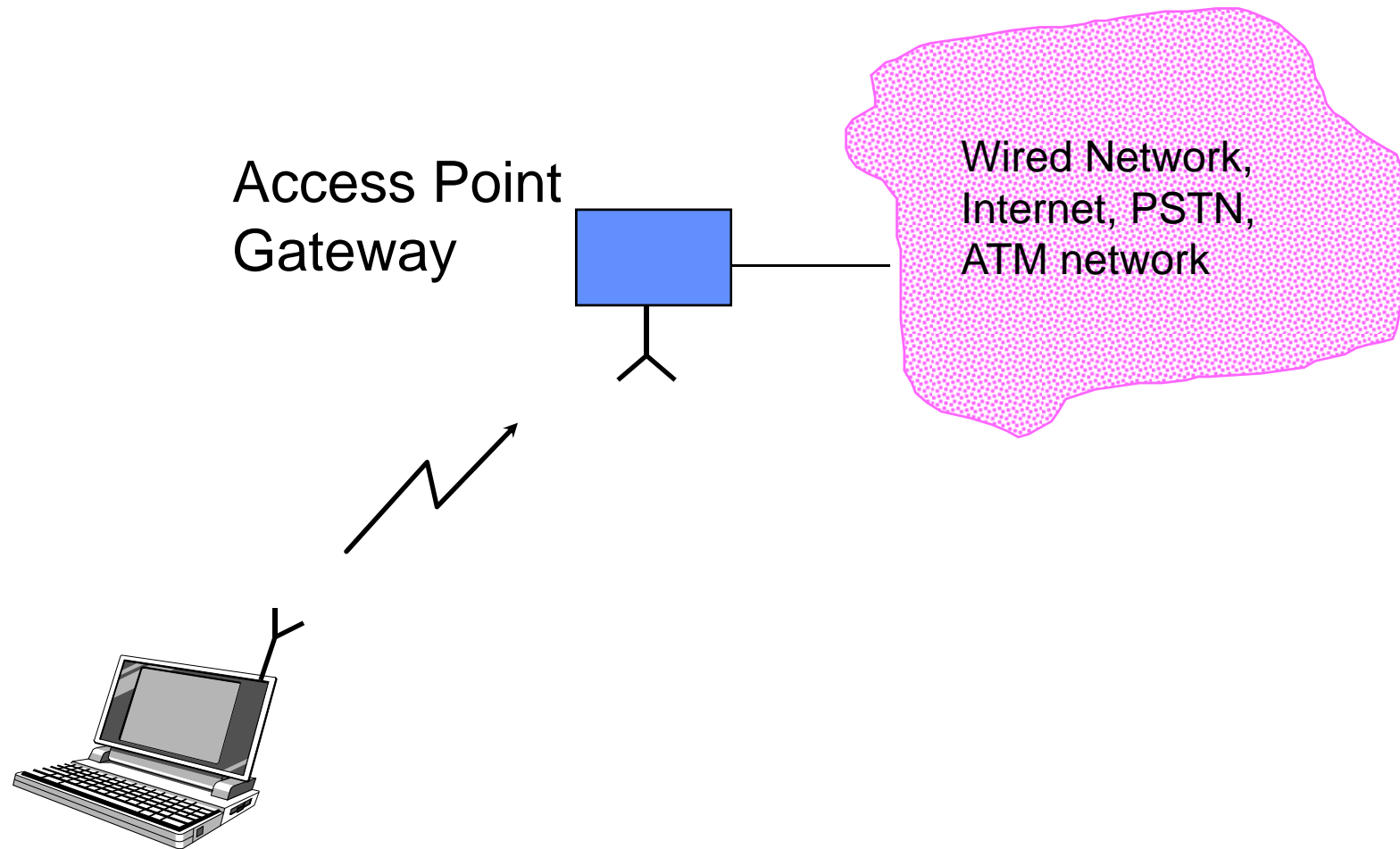

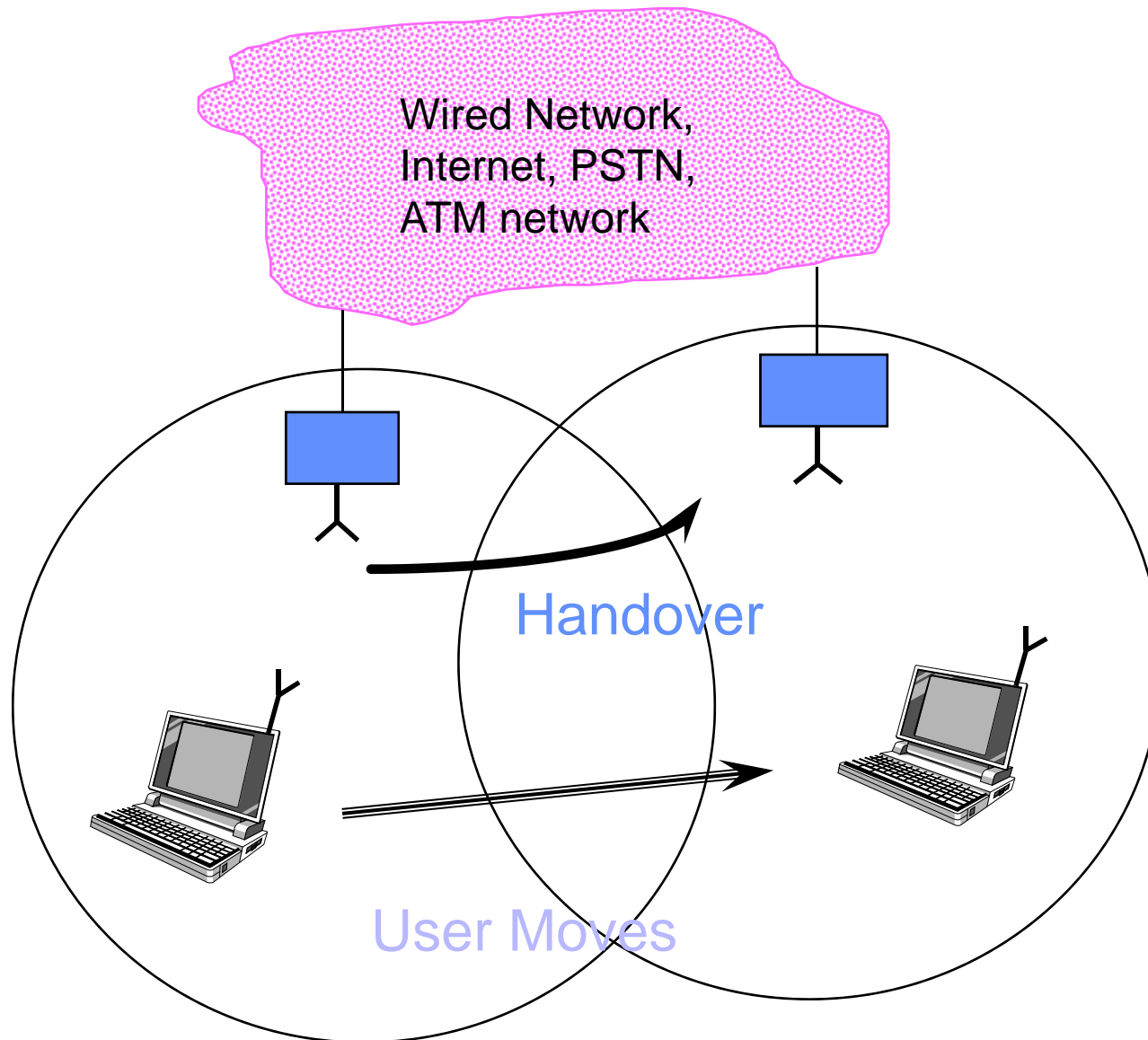

Typical Cellular Call

- ◆ Initialization (find your base-station)
- ◆ Service Request
 - Location Level : Paging
 - Channel Assignments
- ◆ Handoff

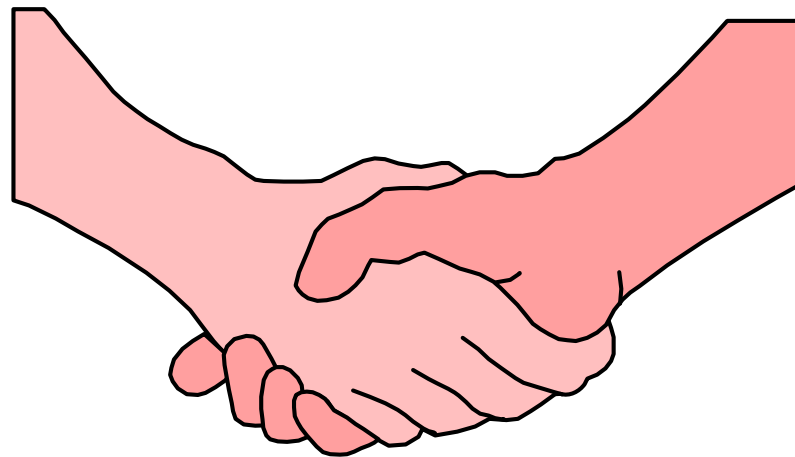

Wireless Comm: Heterogeneity & Security

- ◆ Heterogeneous networks

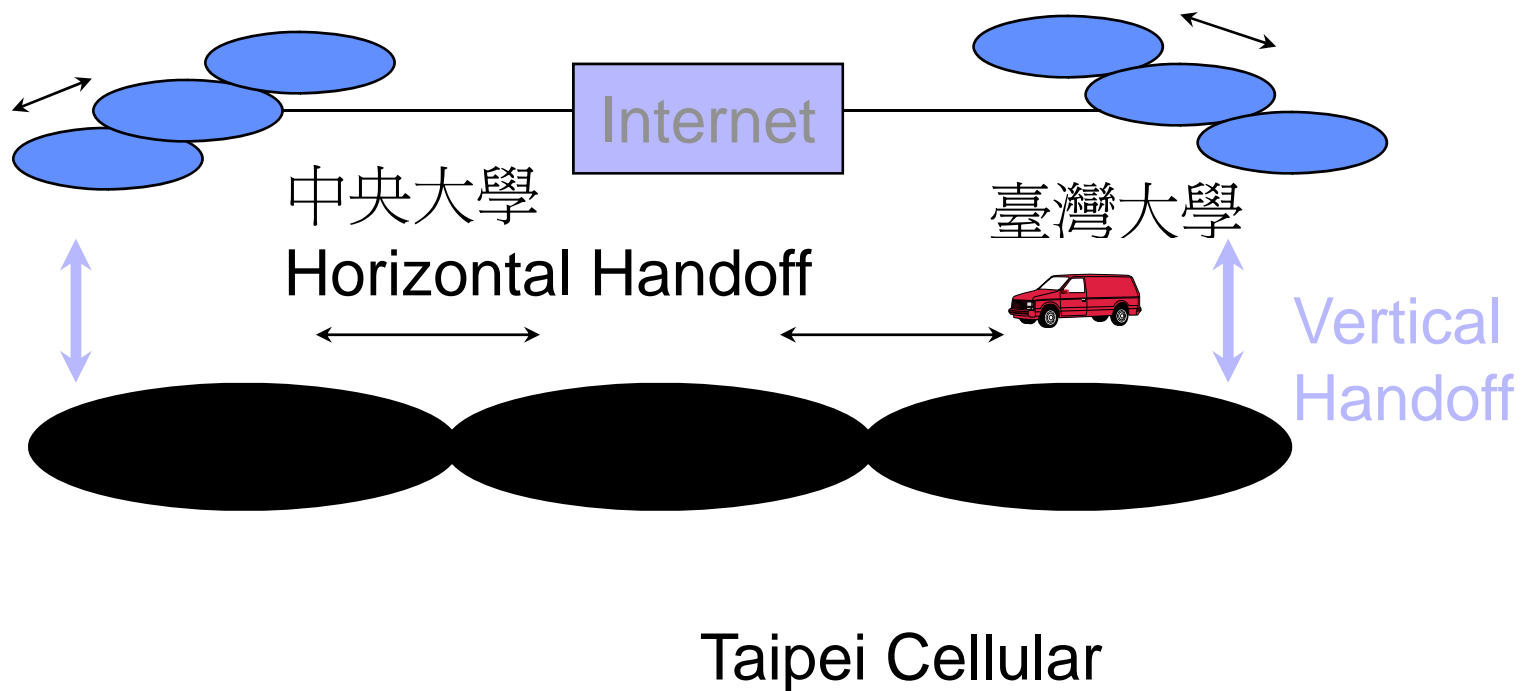

Limited & Variable Bandwidth

- ◆ Low bandwidth compared to wired
- ◆ Highly variable bandwidth
- ◆ High latency

Wireless Communication

- ◆ More difficult than wired communication
- ◆ Dis-connections

Mobility

- ◆ Address migration
- ◆ Location-dependent information
- ◆ Migration locality

Portability

- ◆ Light weight power
- ◆ Risks to data
- ◆ Small user interface
- ◆ Small storage capacity

Challenges in Mobile Multimedia Infor- System

- ◆ Portable end-points
- ◆ End-to-end Quality of Services
- ◆ Seamless operation under context (location) changes
- ◆ Context-aware operation
- ◆ Secure operation

Channel Propagation and Fading

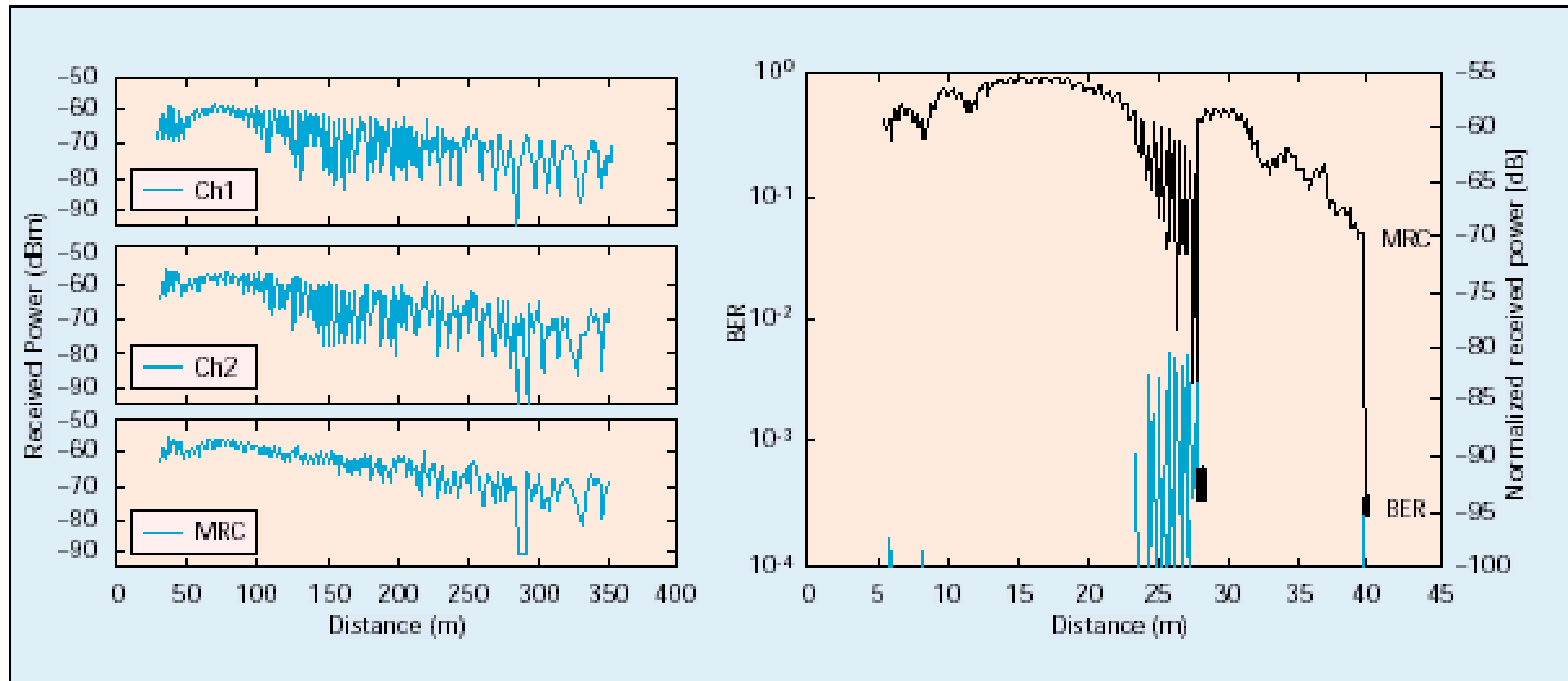

■ Figure 4. Received power as a function of distance: in a street (left), in a pavilion (right); BER and handover (right).