

無線網路多媒體系統 Wireless Multimedia System

Radio Propagation: Issues & Models

Dr. Eric Hsiaokuang Wu

<http://wmlab.csie.ncu.edu.tw/course/wms>

We
provide
無線網路多媒體實驗室
Wireless
Wireless Network & Multimedia Laboratory
Solution

Lecture II Agenda

- ◆ Radio Propagation
 - Physical of radio propagation
 - Two types of propagation models
 - Outdoor vs. Indoor Radio Propagation Model
 - How to do simple “link budget” calculation
 - Combating the radio channel impairment

- ◆ Wireless Modem Design

- ◆ Modern Application: 911 services



Reading list for This Lecture

- ◆ Required Reading:

(Jorgen95) J. B. Andersen, T. S. Rappaport, “Propagation Measurements and Models for Wireless Communications channels”, (IEEE Communication Magazine), pp. 42~49

(Jeffrey H98) Jeffrey H. Reed, Kevin J. Krizman, Brian D. Woerner, and T. S. Rappaport, “An Overview of the Challenges and Progress in Meeting the E-911 Requirement for Location Service, (IEEE Communication Magazine), pp.30~37

Further Reading

(Rappaport97) T. S. Rappaport, K. Blankenship, H. Xu, “Propagation and Radio System Design Issues in Mobile Radio Systems for the GloMo Project

The mystery of the Radio Propagation



How to deal with Radio Propagation

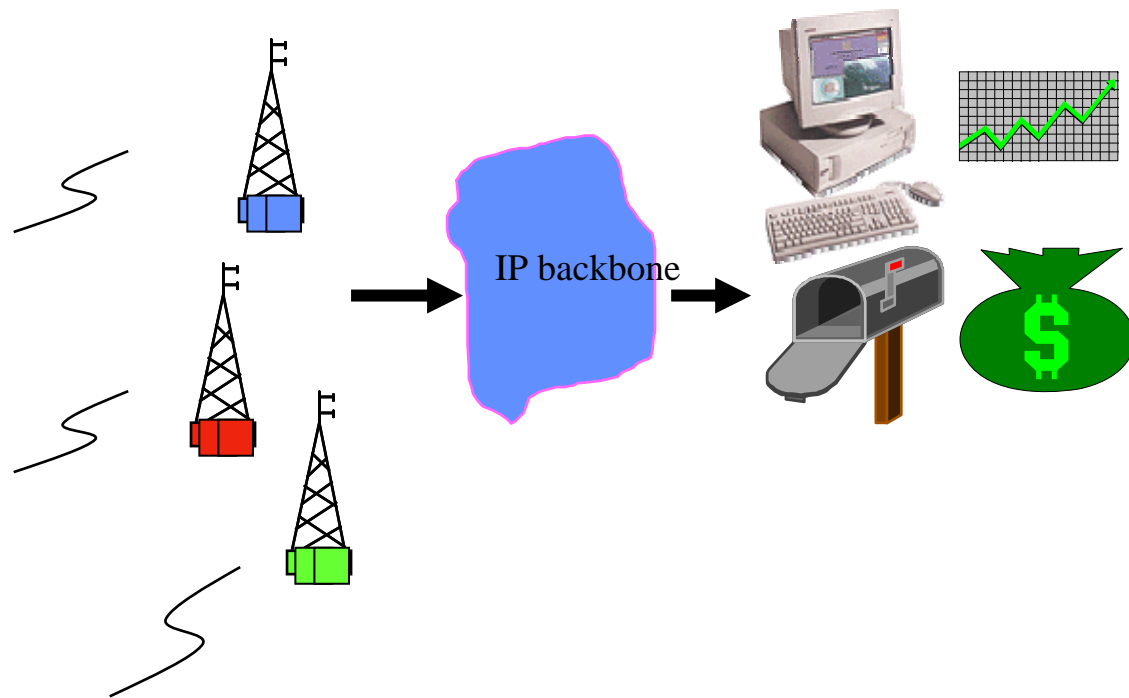

Where are you from?

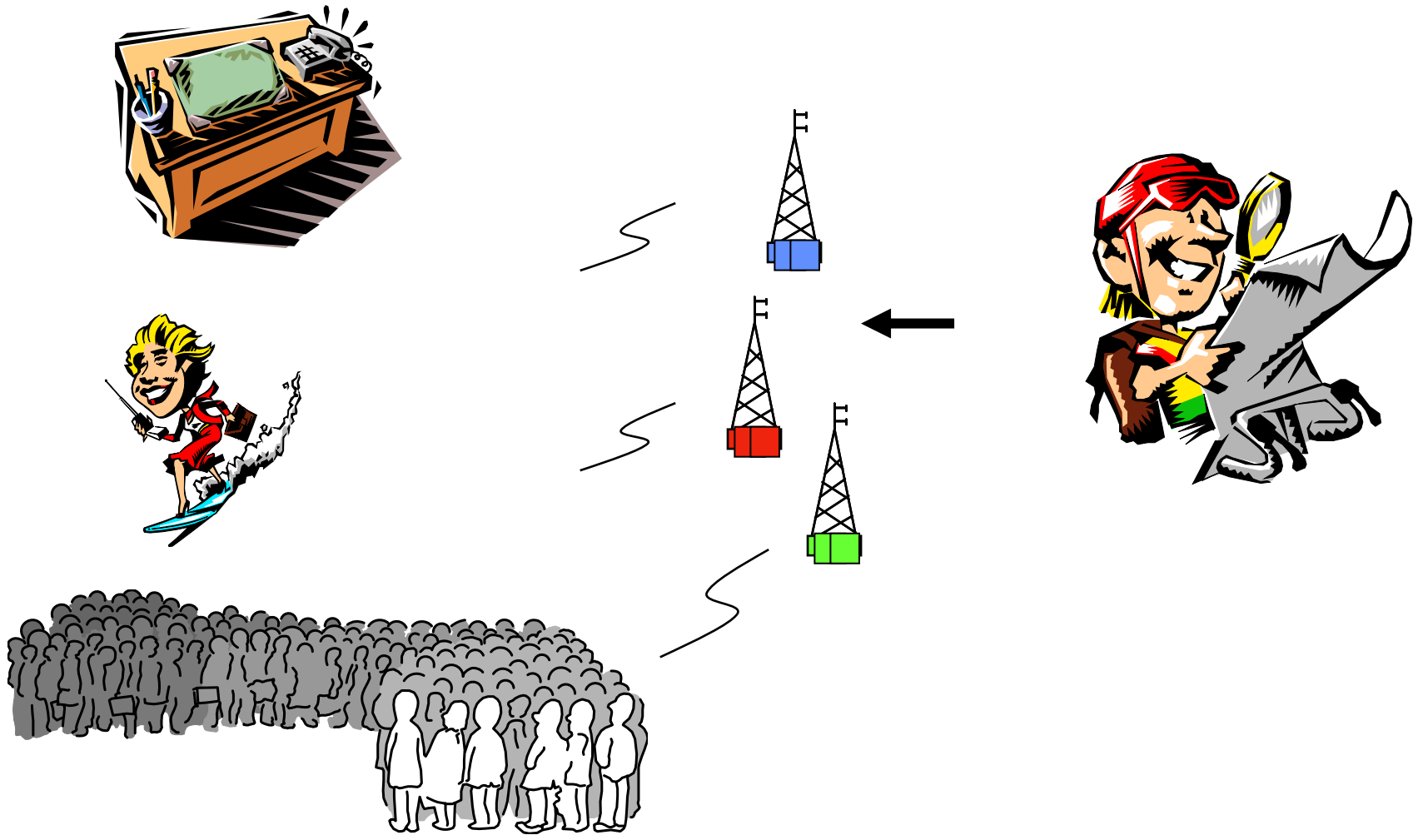

QoS and Multimedia Traffic Support

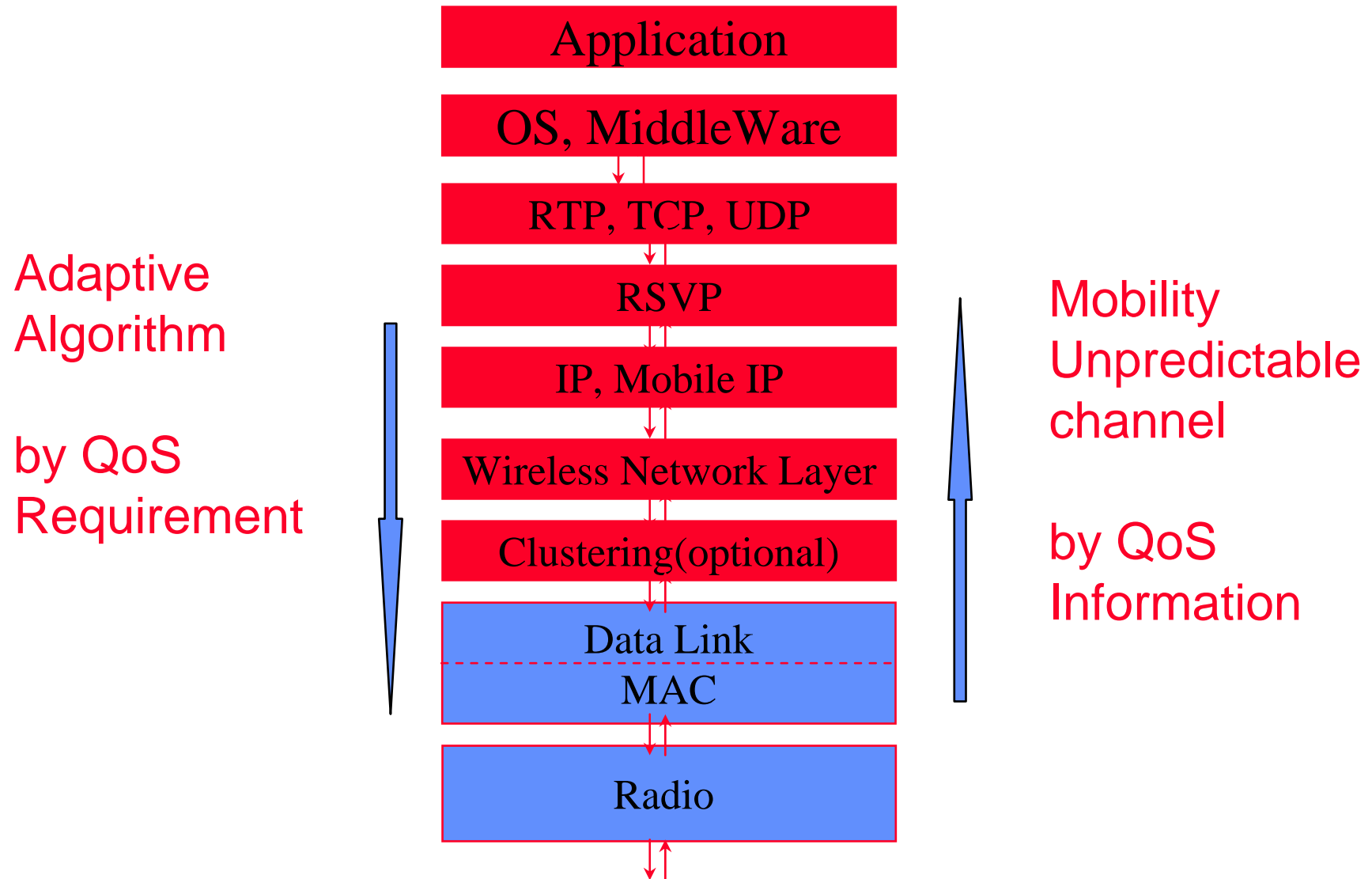

Simplified View of a Digital Radio Link

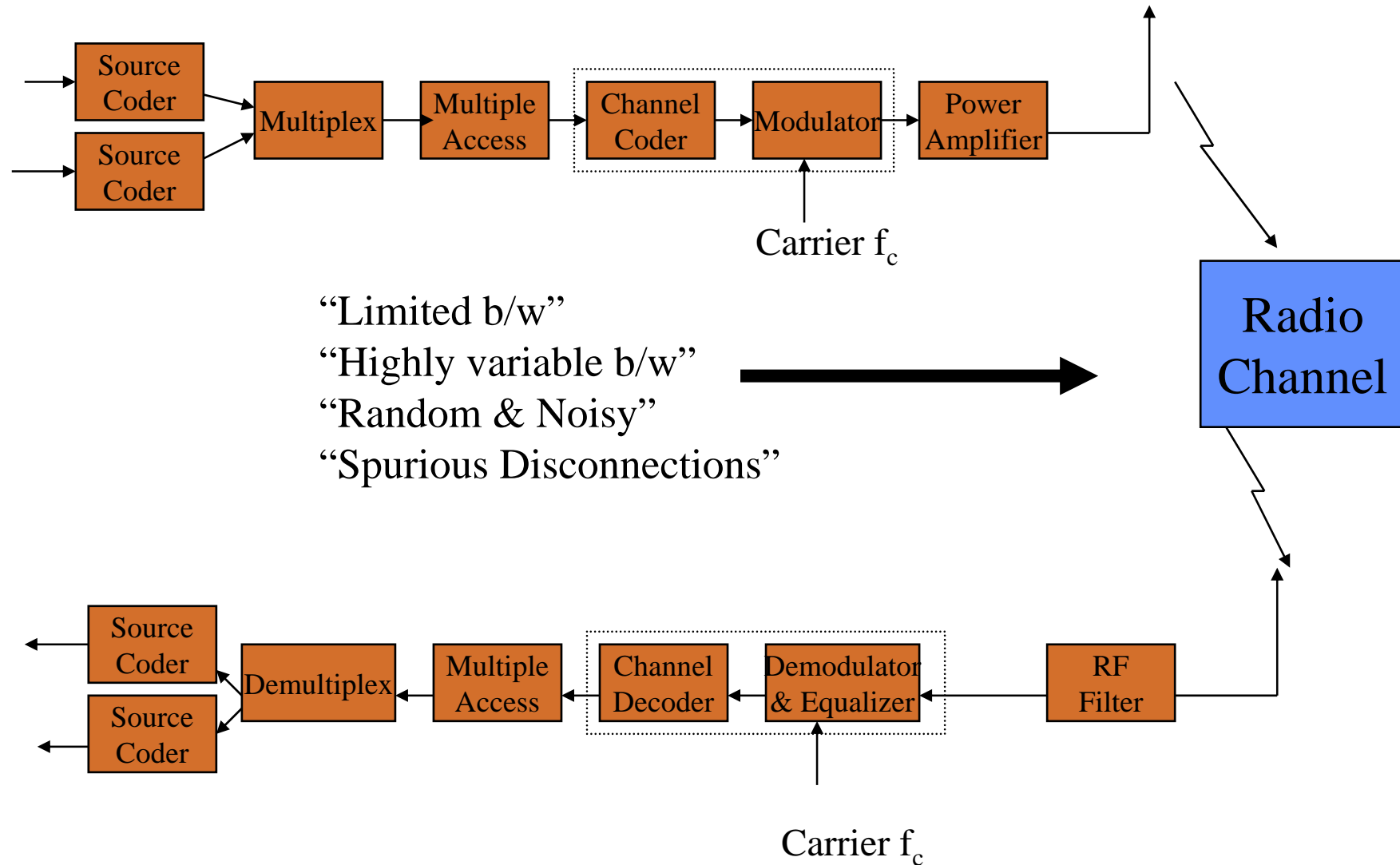

Digital to Analog Modulation

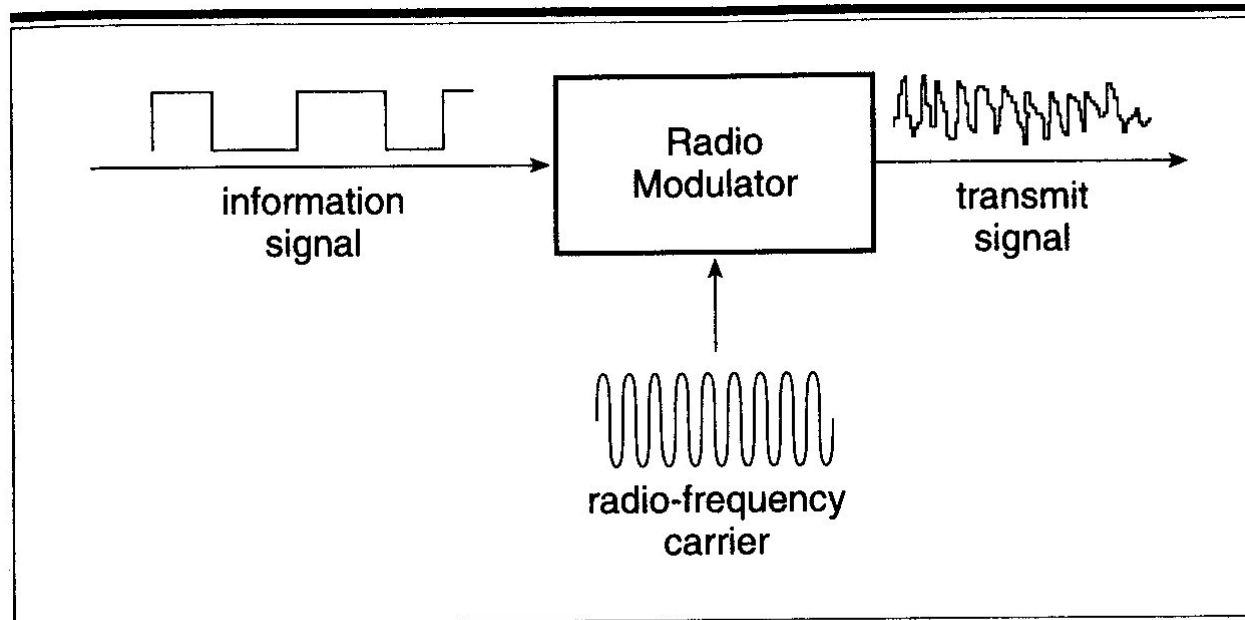

Figure 6.2 Single-stage digital modulation (TDMA and FDMA).

Digital-Digital-Analog Modulation

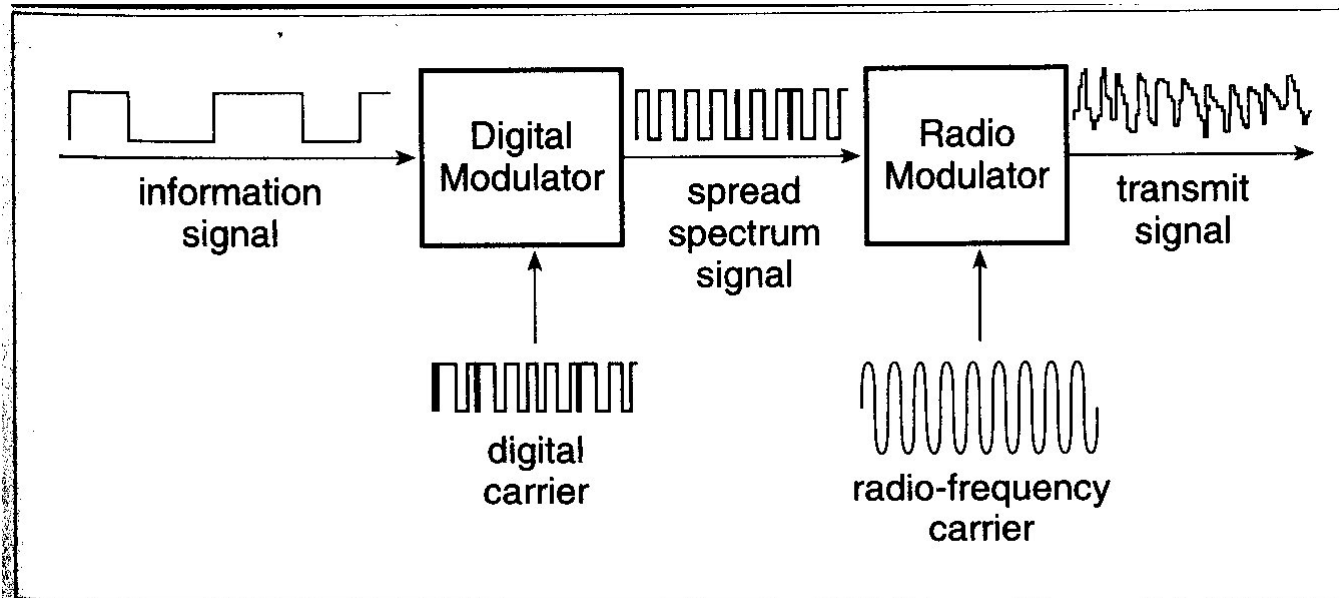

Figure 6.3 Two stages of modulation in a spread spectrum system.

Digital Correlator

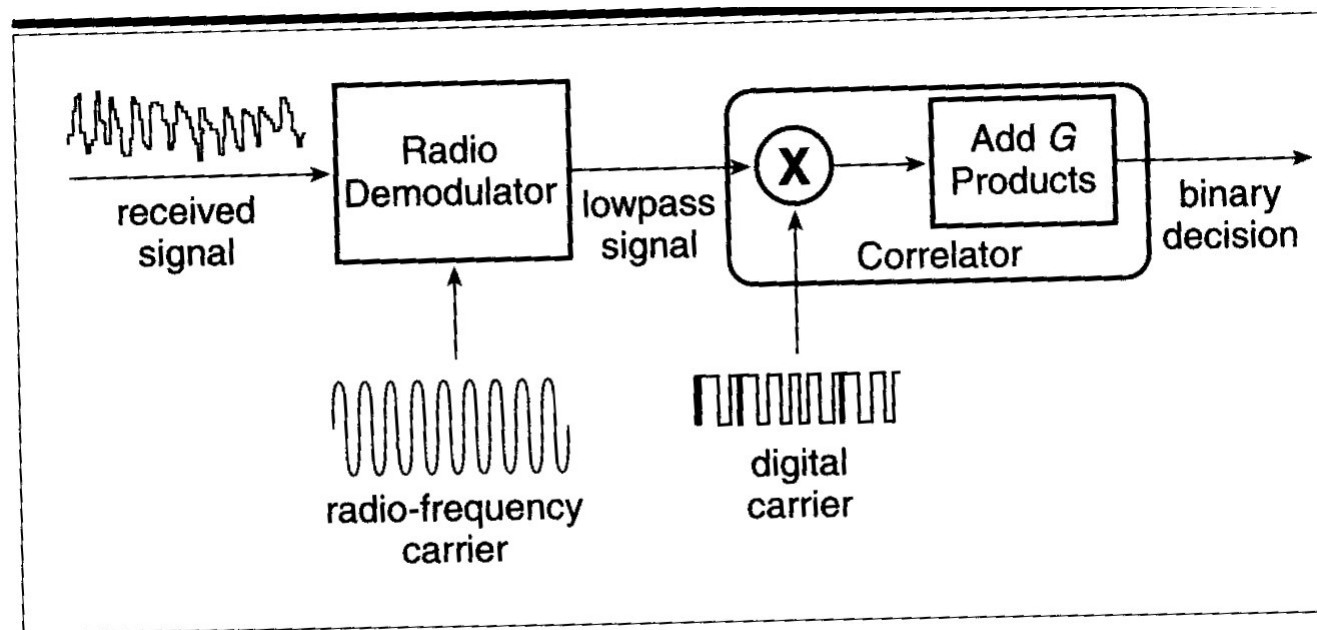
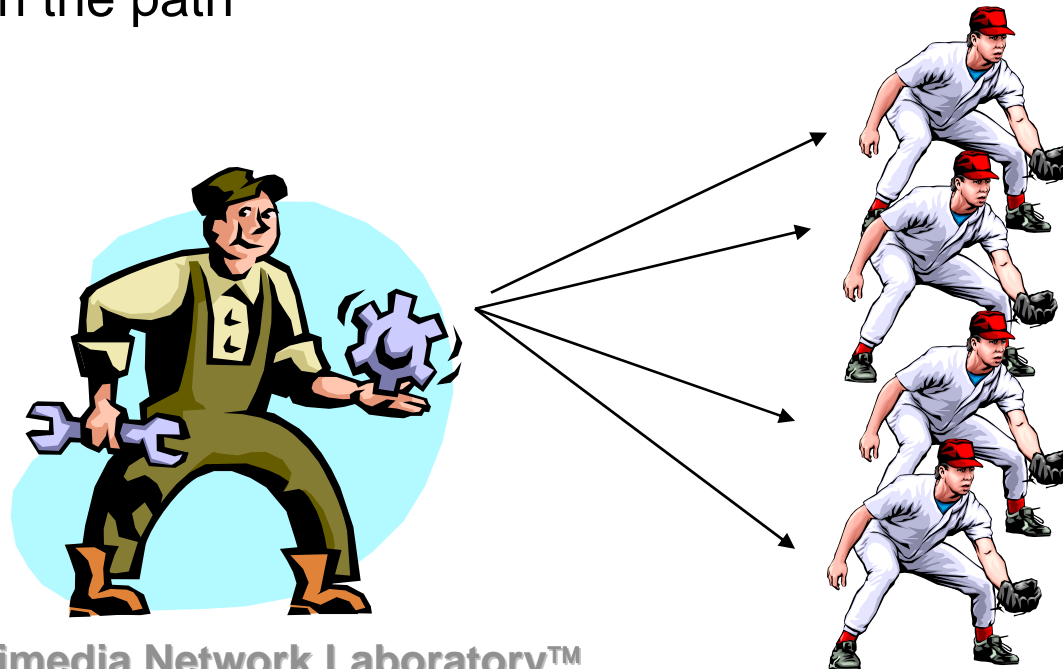

Figure 6.4 Two stages of demodulation in a spread spectrum receiver.

Multiple correlators

- ◆ Multiple correlators in each receiver
- ◆ At any instant of time, the signal carriers in the different correlators are synchronize to signal paths with different propagation times
- ◆ A search circuit examines the arriving signal in order to detect the appearance of a new path, then assign a correlator to synchronize the signal on the path



Key role for the radio propagation

- ◆ Radio Propagation determines
 - the area which could be covered
 - The maximum data rate in a system
 - Battery power requirement for mobile transceivers

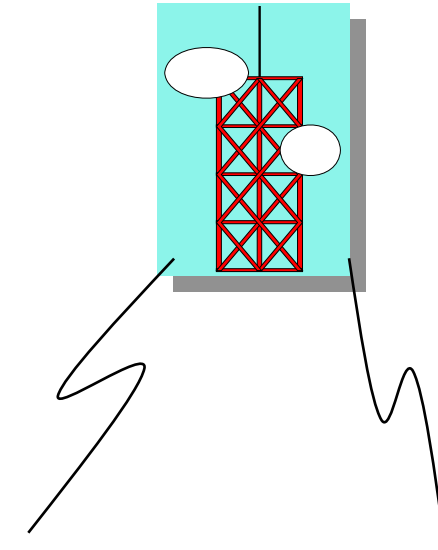



Speed, Wavelength, Frequency

Light speed = Wavelength x Frequency
 $= 3 \times 10^8 \text{ m/s} = 300,000 \text{ km/s}$

System	Frequency	Wavelength
AC current	60 Hz	5,000 km
FM radio	100 MHz	3 m
Cellular	800 MHz	37.5 cm
Ka band satellite	20 GHz	15 mm
Ultraviolet light	10^{15} Hz	10^{-7} m

Types of Waves

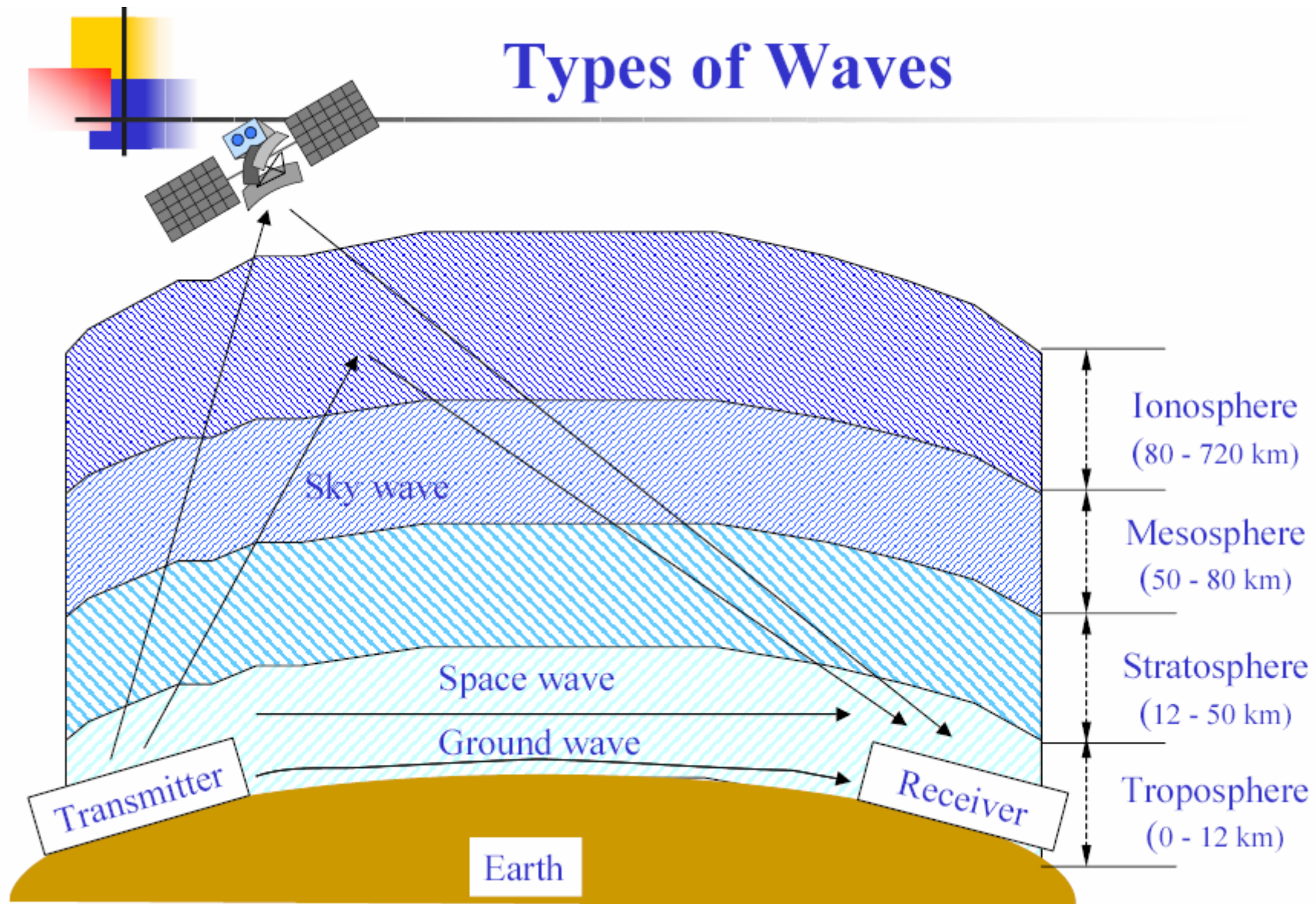



Radio Frequency Bands

Classification Band	Initials	Frequency Range	Characteristics
Extremely low	ELF	< 300 Hz	
Infra low	ILF	300 Hz • •3 kHz	
Very low	VLF	3 kHz • •30 kHz	
Low	LF	30 kHz • •300 kHz	Surface/ground wave
Medium	MF	300 kHz • •3 MHz	
High	HF	3 MHz • •30 MHz	Sky wave
Very high	VHF	30 MHz • •300 MHz	Space wave
Ultra high	UHF	300 MHz • •3 GHz	
Super high	SHF	3 GHz • •30 GHz	
Extremely high	EHF	30 GHz • •300 GHz	Satellite wave
Tremendously high	THF	300 GHz • •3000 GHz	

Radio Channel

- ◆ Free Space
- ◆ Land Mobile
- ◆ Multi-path Propagation
- ◆ Shadow



Some Distributions

- ◆ Normal (Gaussian)
- ◆ Log-normal Distribution
- ◆ Rayleigh Distribution
- ◆ Rician Distribution
 - Dominant path
- ◆ Impulse Response



Propagation Mechanisms in Space with Objects

- ◆ Reflection (with Transmittance and Absorption)
 - Radio wave impinges on an object
 - Surface of earth, walls, buildings, atmospheric layers
 - If perfect (lossless) dielectric object, then zero absorption
 - If perfect conductor, then 100% reflection
- ◆ Diffraction
 - Radio path is obstructed by an impenetrable surface with sharp irregularities (edges)
 - Secondary waves “bend” around the obstacle (Huygen’s principle)
 - Explain how RF energy can travel without LOS
 - “shadowing”
- ◆ Scattering (diffusion)
 - Similar principles as diffraction, energy reradiated in many directions

Reflection, Diffraction, and Scattering in Real-Life

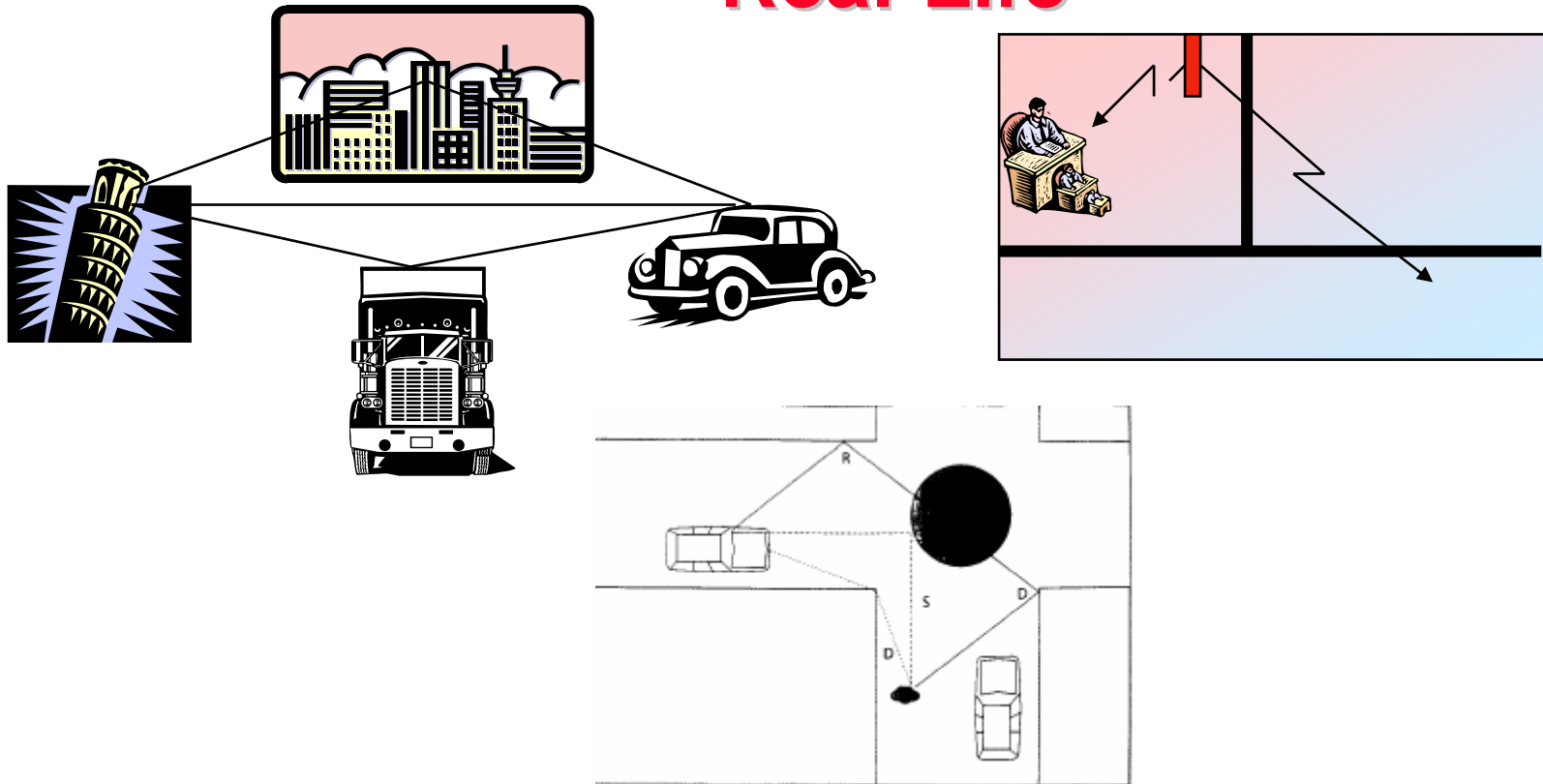

- ◆ Received signal often a sum of contributions from different directions
- ◆ Random phases make the sum behave as noise (Rayleigh Fading)

Small-scale and Large-scale Fading

- ◆ Signal fades rapidly as receiver moves, but the local average signal changes much more slowly

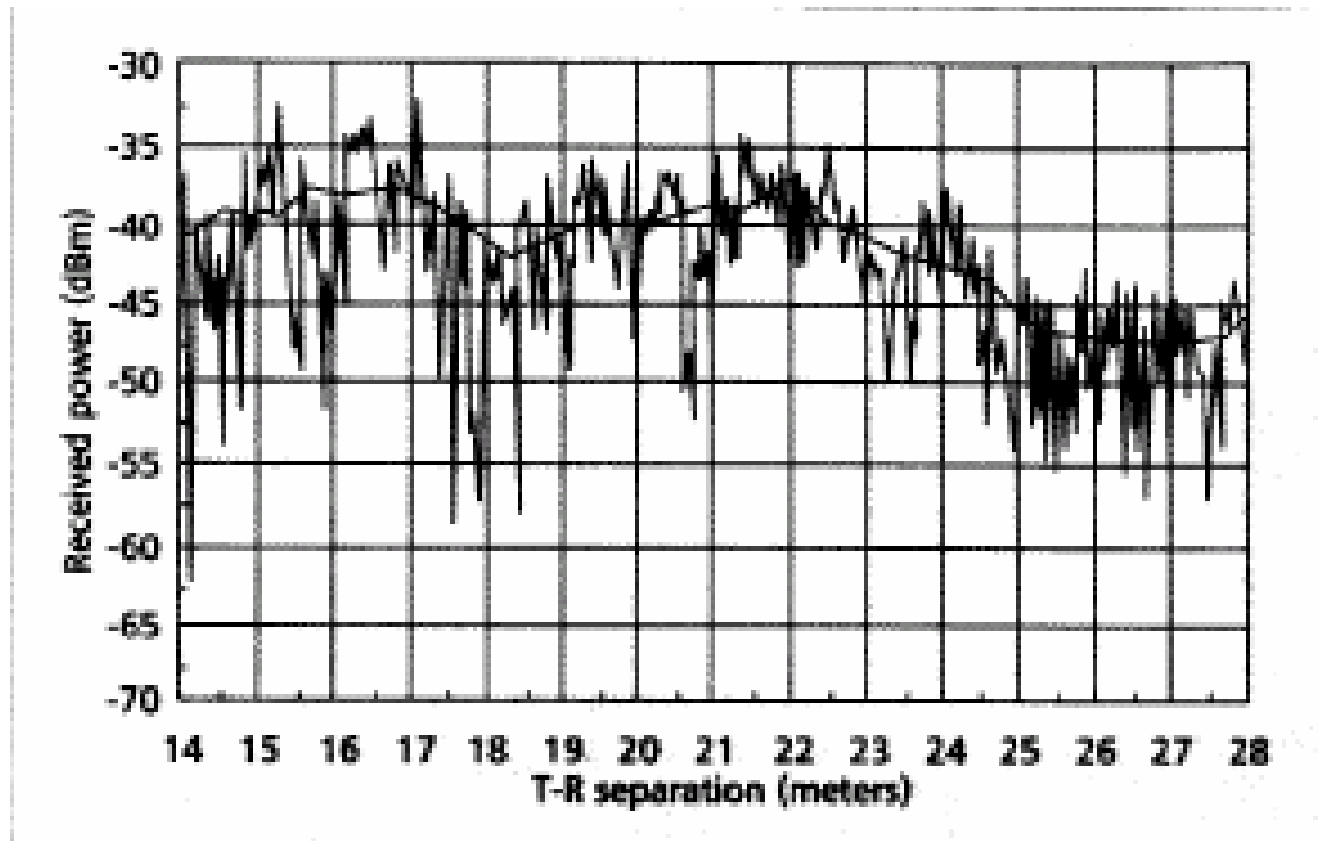

Path Loss (Free-space)

- Definition of path loss L_P :

$$L_P = \frac{P_t}{P_r},$$

Path Loss in Free-space:

$$L_{PF}(dB) = 32.45 + 20 \log_{10} f_c (MHz) + 20 \log_{10} d(km),$$

where f_c is the carrier frequency.

This shows greater the f_c , more is the loss.

Land Propagation

- The received signal power:

$$P_r = \frac{G_t G_r P_t}{L}$$

where G_r is the receiver antenna gain,

L is the propagation loss in the channel, i.e.,

$$L = L_p L_S L_F$$

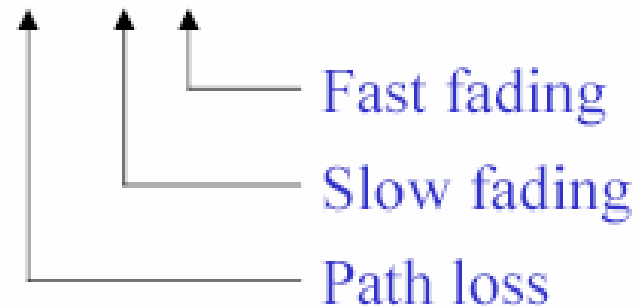

Path Loss (Free-space)

- Definition of path loss L_p :

$$L_p = \frac{P_t}{P_r},$$

Path Loss in Free-space:

$$L_{pF} (dB) = 32.45 + 20 \log_{10} f_c (MHz) + 20 \log_{10} d (km),$$

where f_c is the carrier frequency.

This shows greater the f_c , more is the loss.



Example of Path Loss (Free-space)

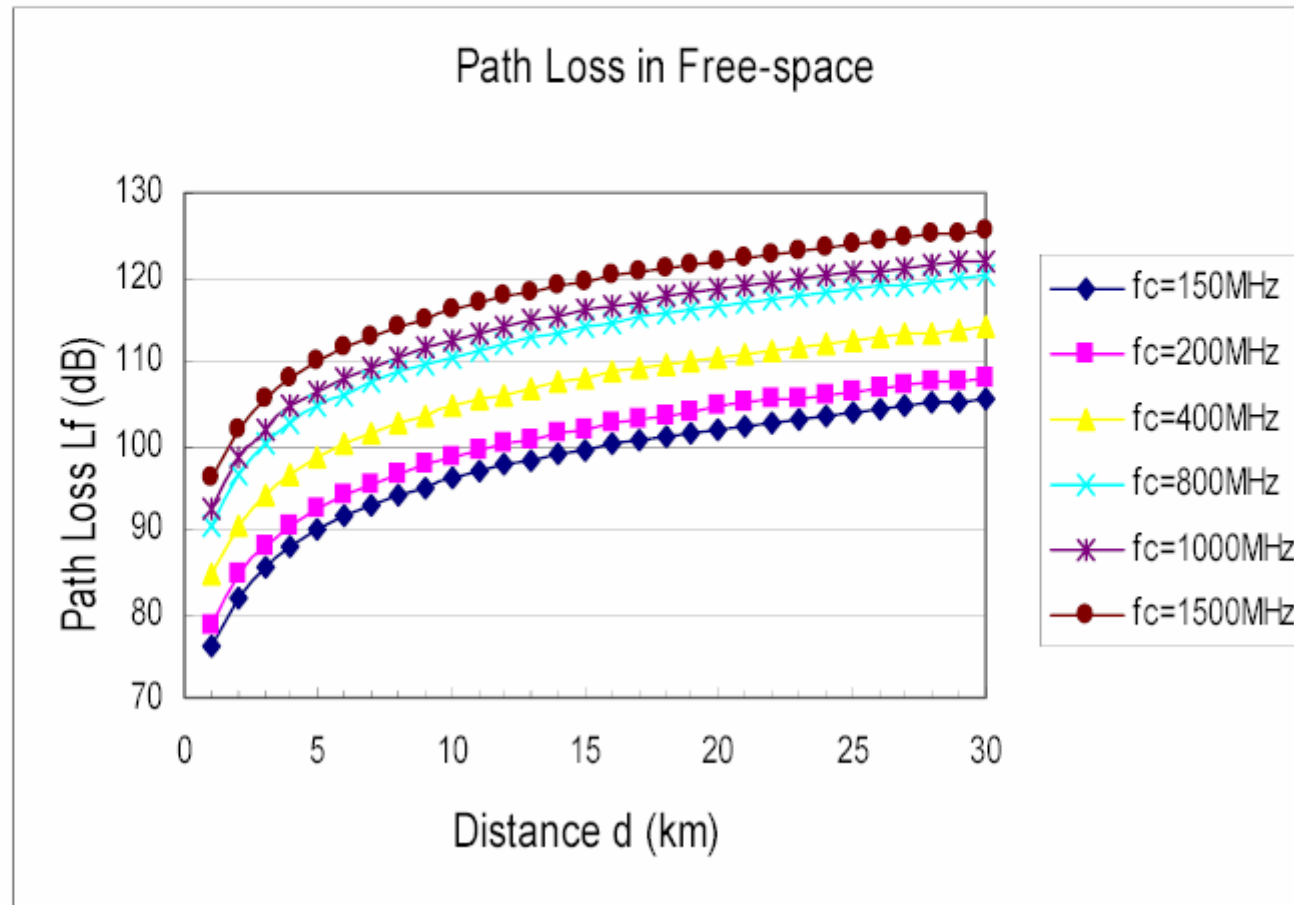



Example of Path Loss (Urban Area: Large City)

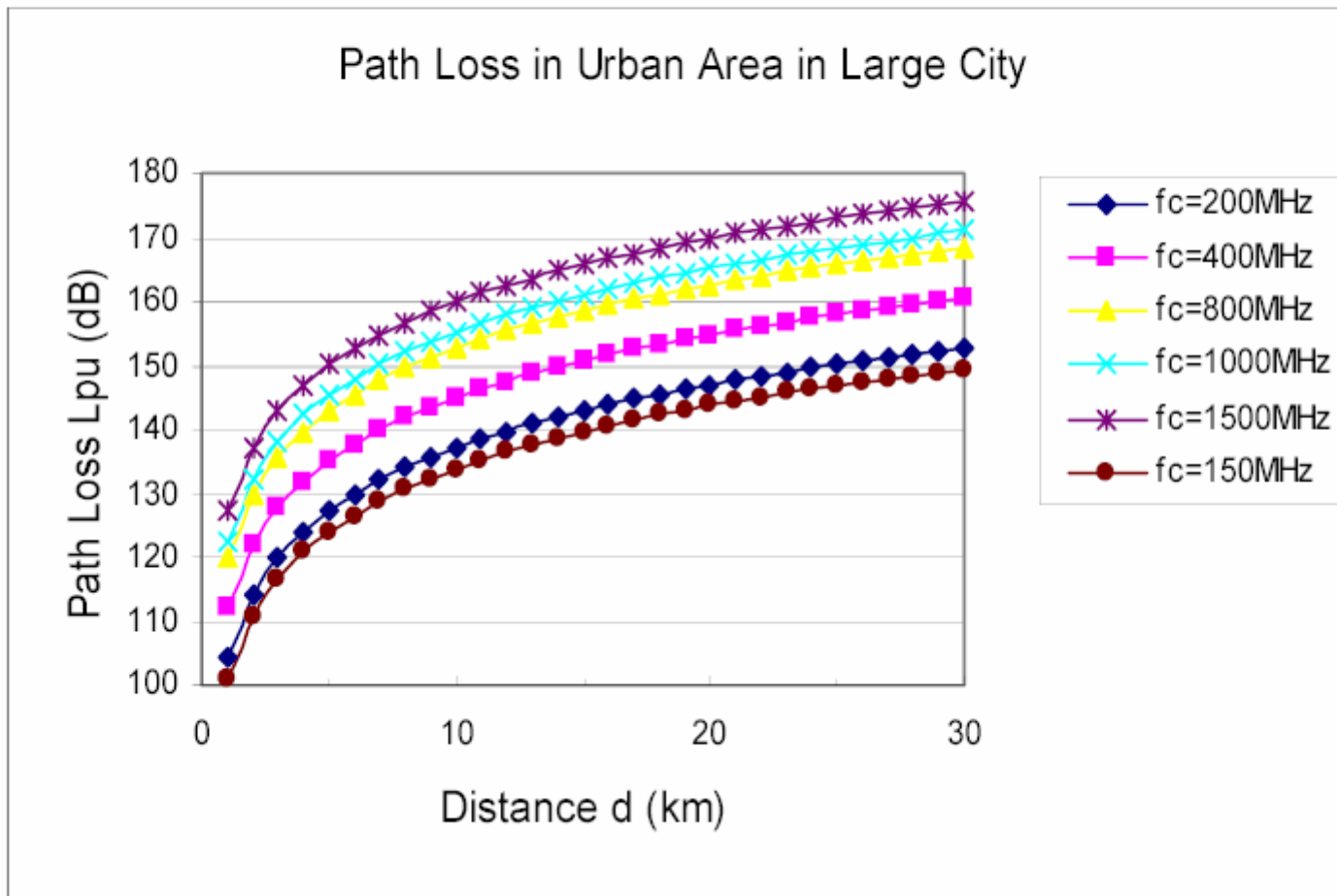

Example of Path Loss (Suburban Area)

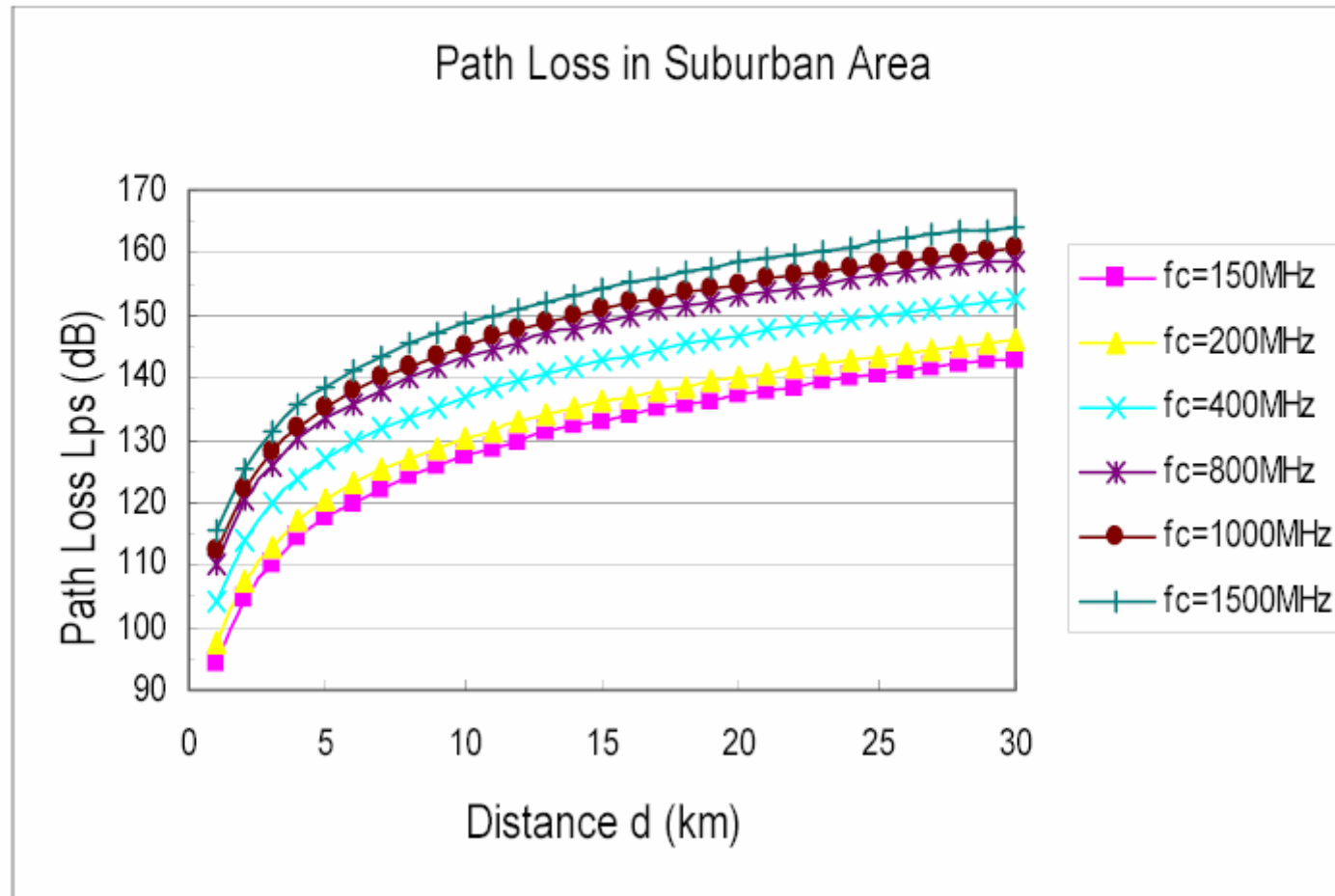



Fading

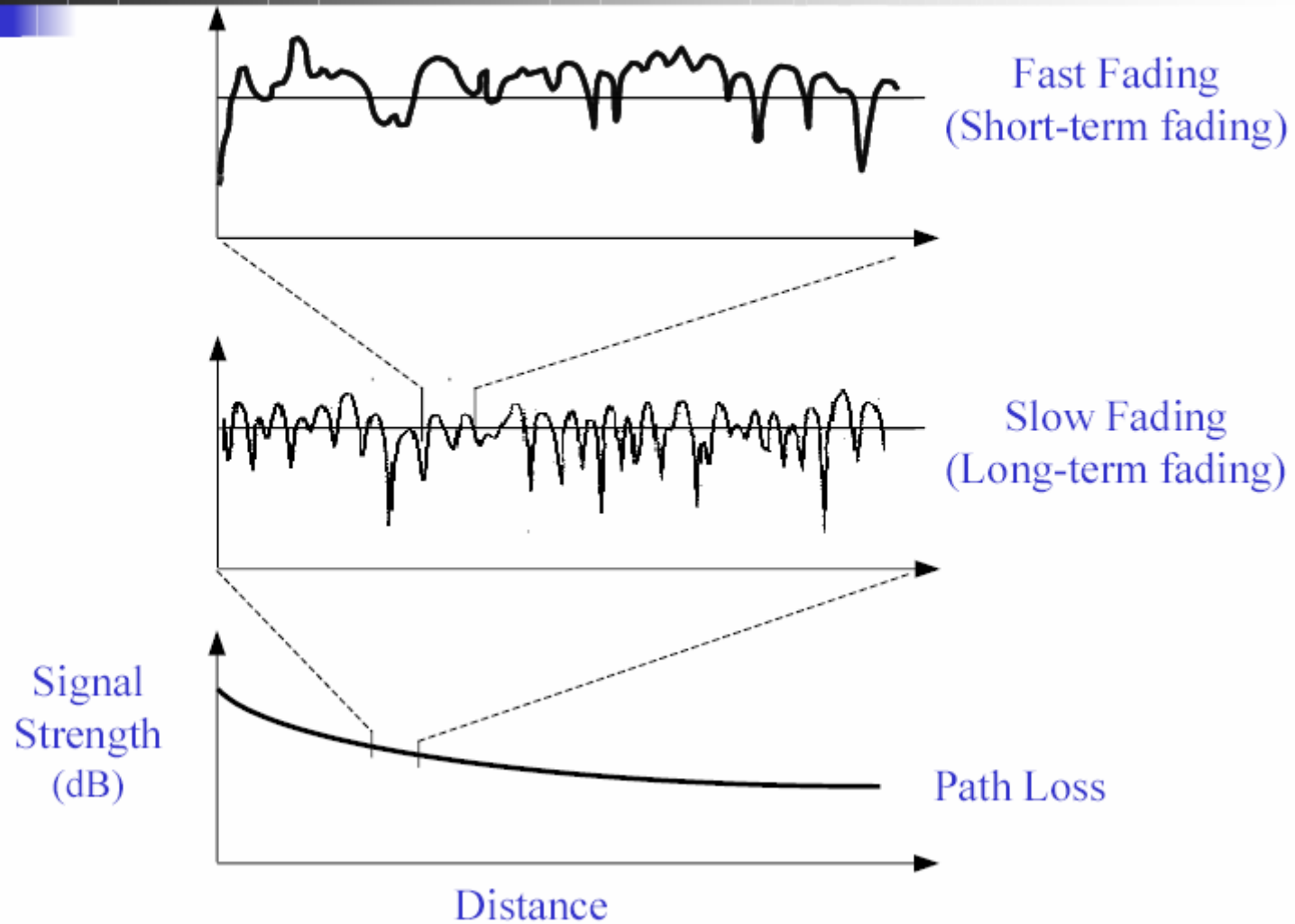

Analysis of the Propagation

- ◆ Large Scale Effect
 - The variation of the mean received signal strength over large distance or long time intervals

- ◆ Small Scale Effect
 - The fluctuations of the received signal strength about a local mean, where these fluctuations occur over small distances or short time interval

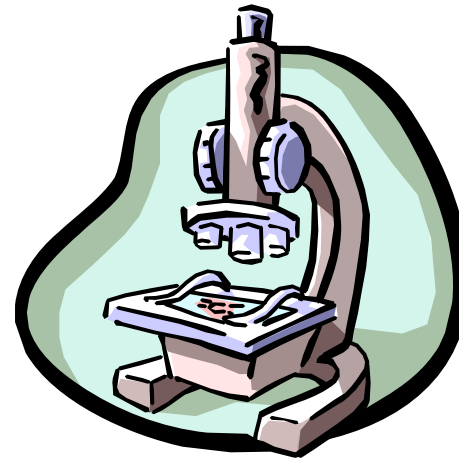

Large Scale -> Link Budget



Slow Fading

- The long-term variation in the mean level is known as slow fading (shadowing or log-normal fading). This fading caused by shadowing.
- Log-normal distribution:
 - The pdf of the received signal level is given in decibels by

$$p(M) = \frac{1}{\sqrt{2\pi}\sigma} e^{-\frac{(M-\bar{M})^2}{2\sigma^2}},$$

where M is the true received signal level m in decibels, i.e., $10\log_{10}m$,
 \bar{M} is the area average signal level, i.e., the mean of M ,
 σ is the standard deviation in decibels



Log-normal Distribution

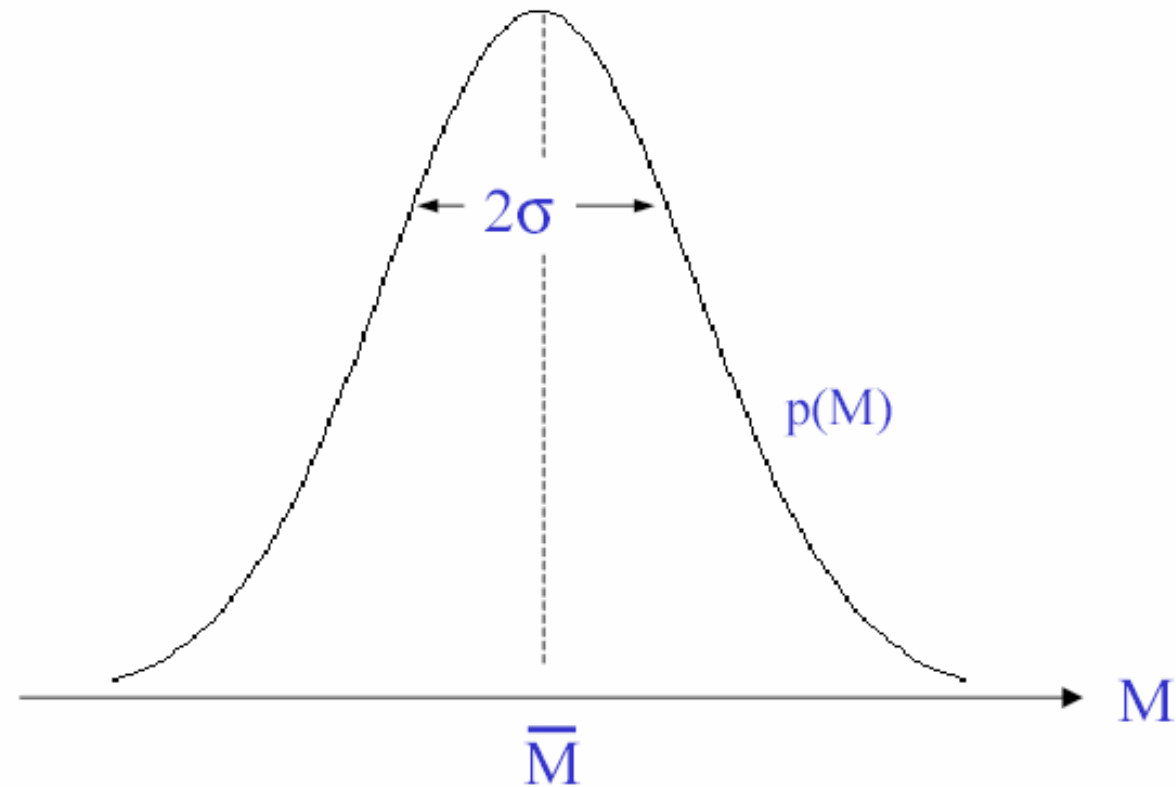

The pdf of the received signal level

Free Space Propagation Model

- ◆ Used when Transmitter and Receiver have a clear, unobstructed, line of sight (LOS) path
 - e.g. satellite channels, microwave LOS radio links

- ◆ Free space power at a receiver antenna at a distance d from transmitter antenna is

$$P_r(d) = \frac{P_t G_t G_r \lambda^2}{(4\pi)^2 d^2 L}$$

where,

G_t and G_r are antenna gains

$L \geq 1$ is the system loss factor not related to propagation (e.g. loss due to filter losses, hardware)

- ◆ Path loss = signal attenuation as a positive quantity in dB

$$Pl(dB) = 10 \log \frac{P_t}{P_r}$$

$$P_t(dBm) = 10 \log [P_t(mW) / 1mW]$$

Radio Propagation Effects

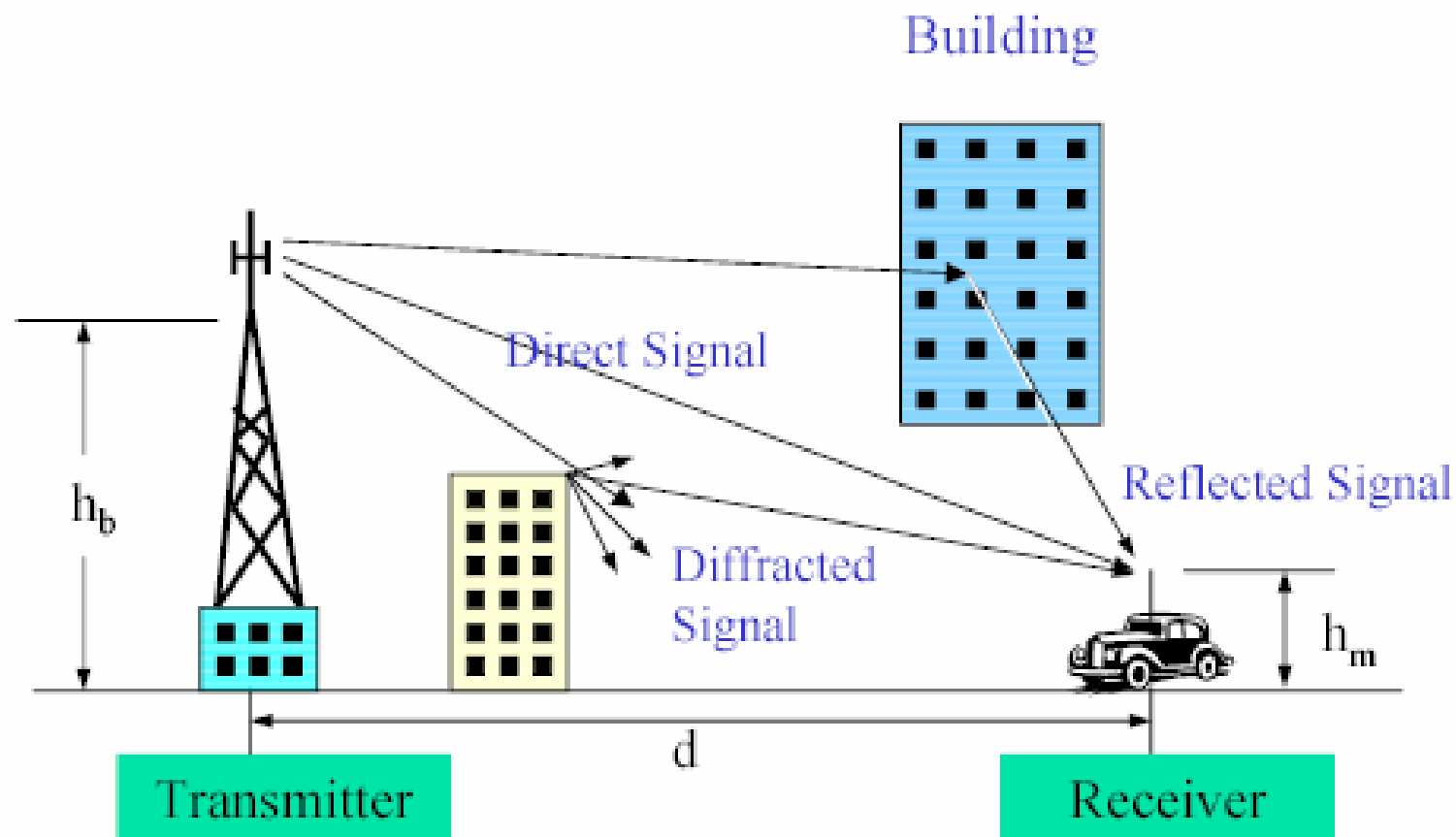

Example: Ground Reflection (2-Ray) Model

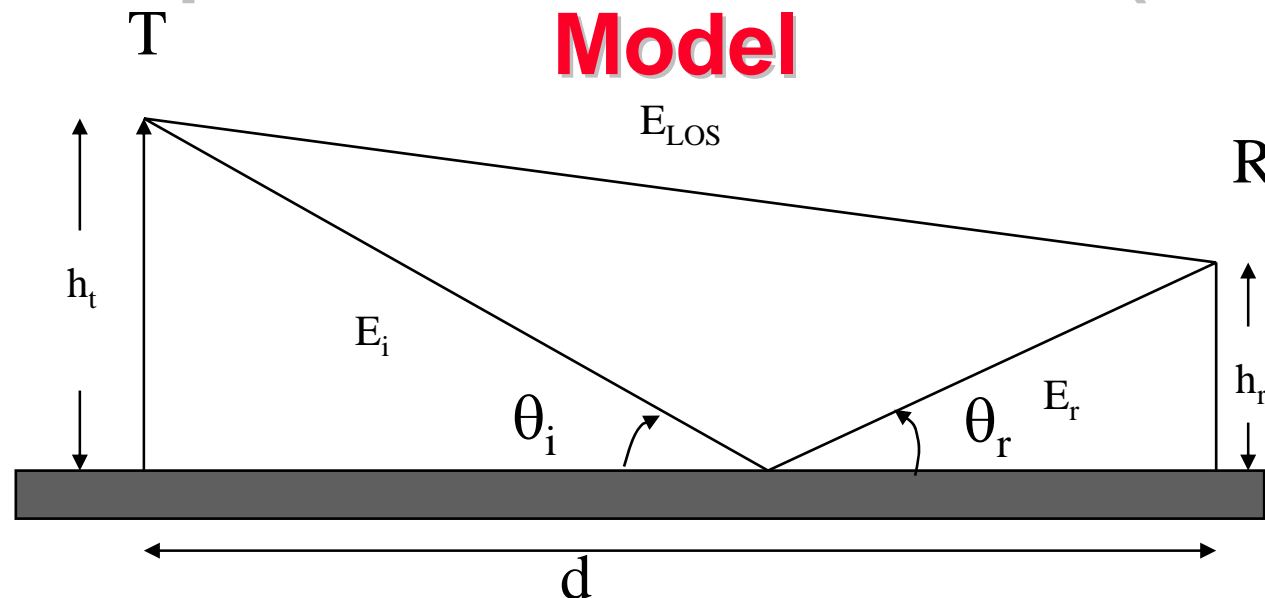

- ◆ Model found a good predictor for large-scale signal strength over distances of several kilometers for mobile systems with tall towers (heights > 50m) as well as for LOS microcell channels
- ◆ Can show (physics) that for large d

$$P_r(d) = \frac{P_t G_t G_r h_t^2 h_r^2}{d^4}$$

- ◆ Much more rapid path loss than expected due to free spaces

Log-Distance Path Loss Model

- ◆ Assume average power (in dB) decreases proportional to log of distance

$$\overline{PL}(d) = \overline{PL}(d_0) + 10n \log\left(\frac{d}{d_0}\right)$$

- ◆ Justification?
 - Measurements
 - Intuition/theory.. Recall; free space, ground-reflection model
- ◆ Problem: “Environment Clutter” may differ at two locations at the same time (Log-normal Shadowing)

$$\overline{PL}(d) = \overline{PL}(d_0) + 10n \log\left(\frac{d}{d_0}\right) + X_\sigma$$

Typical Path Loss Exponent, n

Environment	Path Loss Exponent, n
Free Space	2
Urban area cellular / PCS	2.7 to 4.0
Shadow urban cellular / PCS	3 to 5
In building line of sight	1.6 to 1.8
Obstructed in building	4 to 6
Obstructed in factories	2 to 3

Practical Link Budget Design Using Path Loss Models

- ◆ Bit-Error-rate is a function of SNR (signal-to-noise ratio), or equivalently CIR (carrier-to-interference ratio), at the receiver
 - The “function” itself depends on the modulation scheme
- ◆ Link budget calculations allow one to compute SCR or CIR
- ◆ Battery Life-> Talk Time -> received/Transmitted power -> Path Loss Models



$$SNR(dB) = P_s(dBm) - N(dBm)$$

$$P_s(dBm) = (P_t) + (G_t) + (G_r) - (\overline{PL}(d))$$

$$N = KT_0BF$$

$$N = -174(dBm) + 10\log_{10} B + F(dB)$$

Example Link Budget Calculation

- ◆ Maximum separation distance vs. transmitted power (with fixed BW)
 - Given
 - ◆ Cellular phone with 0.6W transmitted power
 - ◆ Unity gain antenna, 900 MHz carrier frequency
 - ◆ SNR must be at least 25 dB for proper reception
 - ◆ Receiver BW is $B=30\text{KHz}$, noise figure $F=10\text{ dB}$
 - What will be the maximum distance?
 - Solution:
 - ◆ $N = -174\text{ dBm} + 10 \log 30000 + 10\text{ dB}$
 - ◆ For $\text{SNR} > 25\text{ dB}$, we must have $P_r > (-119+25) = -94\text{ dBm}$
 - ◆ $P_t = 0.6\text{W} = 27.78\text{ dBm}$
 - ◆ This allows path loss $PL(d) = P_t - P_r < 122\text{ dB}$
 for free space, $n=2$, $d < 33.5\text{ km}$
 for shadowed urban with $n=4$, $d < 5.8\text{ km}$

Link Budget (SNR)

- ◆ Frequency
- ◆ Power
- ◆ Distance
- ◆ Environments
- ◆ Bandwidth

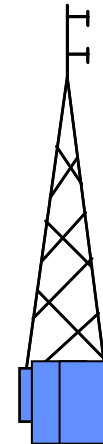
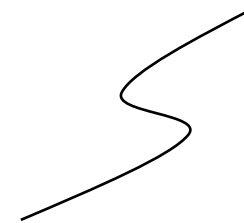

Noise

- ◆ $N = KT_0BF$ ($K = 1.38 \times 10^{-23} \text{ J/K}$ Boltzmann's constant, $T_0 = 290 \text{ K}$)
- ◆ $N(\text{dBm}) = 174(\text{dBm}) + 10 \log_{10} B + F(\text{dB})$

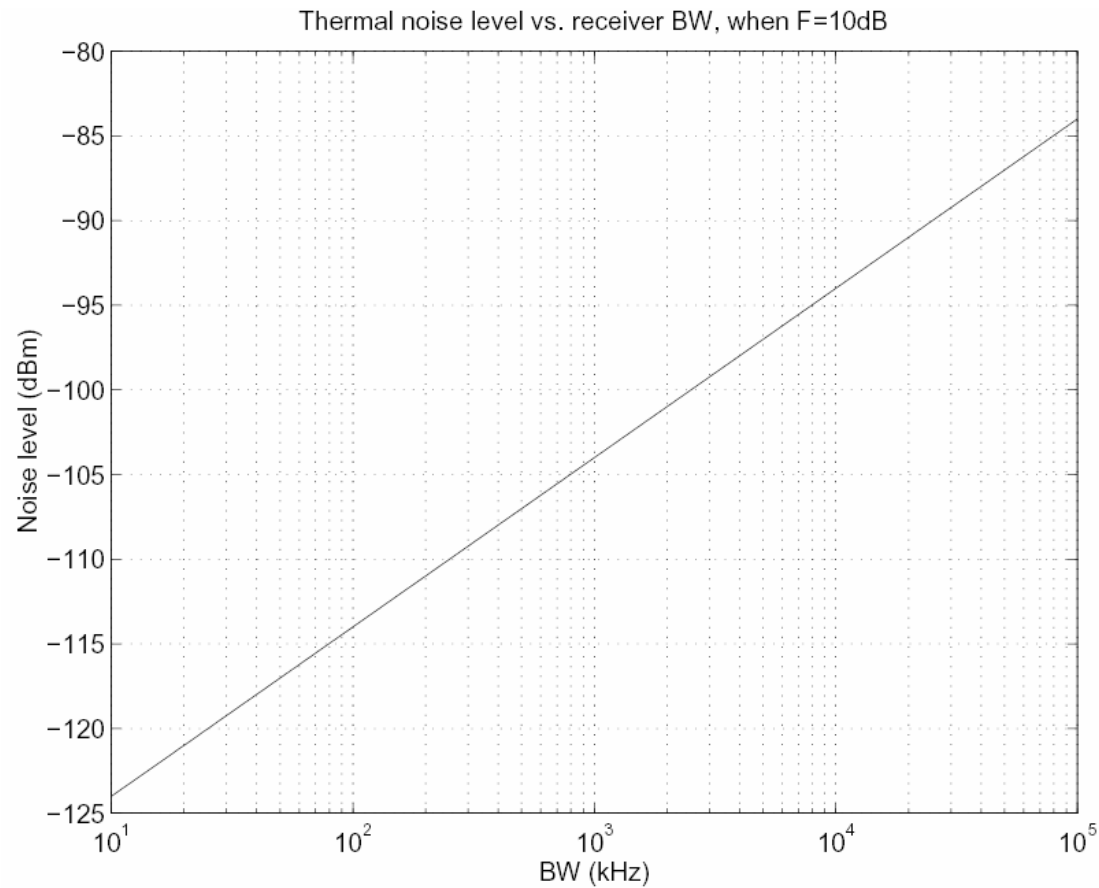

Distance/Power/Battery/Environment

Combined plot of the maximum separation distance and the battery life vs. transmitted power, when BW= 30kHz, F=10 dB, SNR=25 dB.

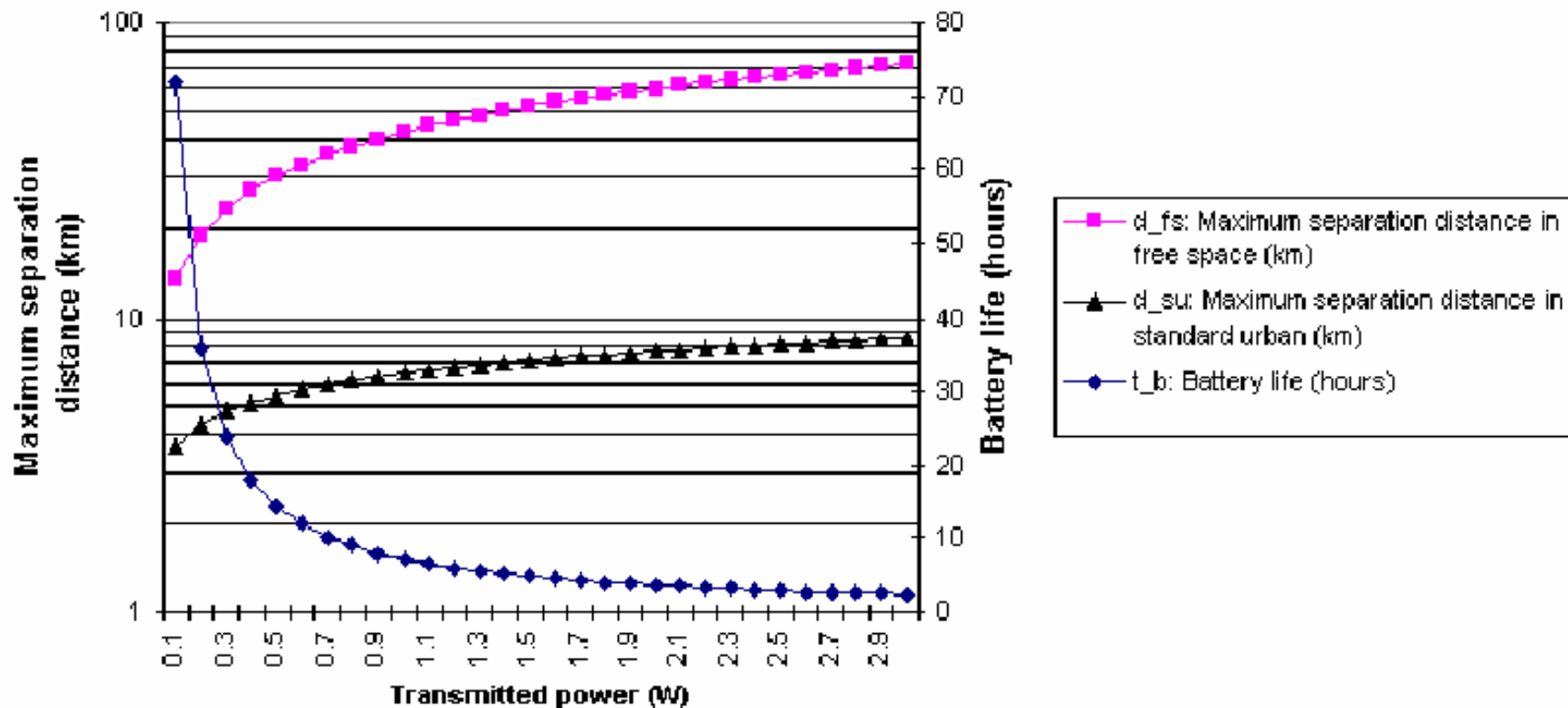

BW/Power/Battery/Environment

Combined plot of the battery life and the maximum transmission BW vs. the transmitted power, when $d=5$ km, $F=10$ dB, $SNR=25$ dB.

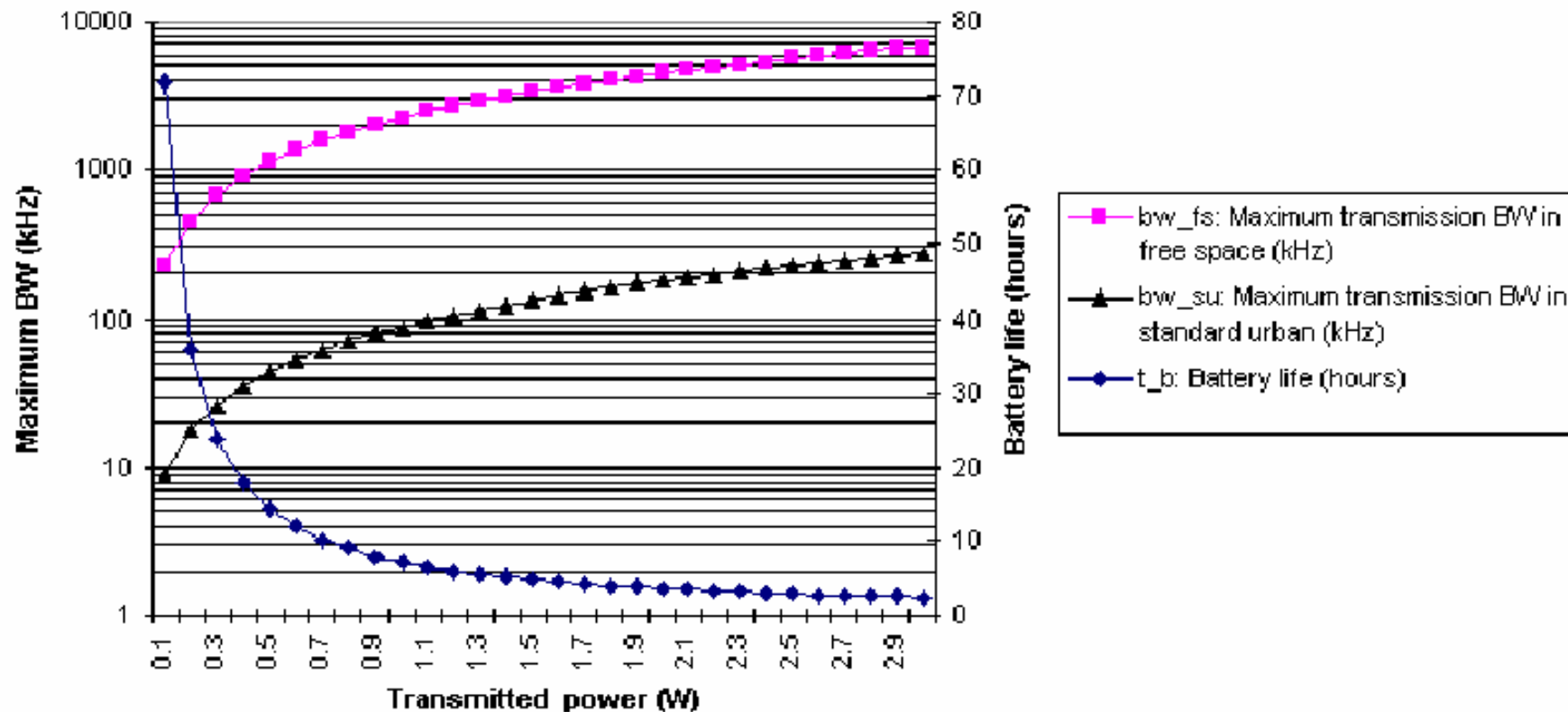

RMS Delay Spreads

TYPICAL RMS DELAY SPREADS IN VARIOUS ENVIRONMENTS.

Environment	Freq. (MHz)	σ_r (ns)	Notes	Source
Urban – New York City	910	1300	Average	[23]
Urban – New York City	910	600	Standard Deviation	[23]
Urban – New York City	910	3500	Maximum	[23]
Urban – San Francisco	892	1000–2500	Worst Case	[24]
Suburban	910	200–310	Averaged Typical Case	[23]
Suburban	910	1960–2110	Averaged Extreme Case	[23]
Indoor – Office Building	1500	10–50		[25]
Indoor – Office Building	1500	25	Median	[25]
Indoor – Office Building	850	270	Maximum	[26]
Indoor – Office Buildings	1900	70–94	Average	[27]
Indoor – Office Buildings	1900	1470	Maximum	[27]

Small Scale -> Quality of Service



Small-Scale Fading Effects (over small t and x)



- ◆ Fading manifests itself in three ways
 - Time dispersion caused by different delays limits transmission rates
 - Rapid changes in signal strength over small x or t
 - Random frequency modulation due to varying Doppler shifts
- ◆ In urban areas, mobile antenna heights \ll height of buildings
 - Usually no LOS from base station
- ◆ Moving surrounding objects also cause time-varying fading

Factors Influencing Small-Scale Fading

- ◆ Multi-path propagation
- ◆ Speed of Mobile
- ◆ Speed of surrounding objects
- ◆ Transmission bandwidth of the signal



Fast Fading

- The signal from the transmitter may be reflected from objects such as hills, buildings, or vehicles.
 - When MS far from BS, the envelope distribution of received signal is Rayleigh distribution. The pdf is

$$p(r) = \frac{r}{\sigma^2} e^{-\frac{r^2}{2\sigma^2}}, \quad r > 0$$

where σ is the standard deviation.

- Middle value r_m of envelope signal within sample range to be satisfied by

$$P(r \leq r_m) = 0.5.$$

- We have $r_m = 1.777 \cdot \sigma$



Rayleigh Distribution

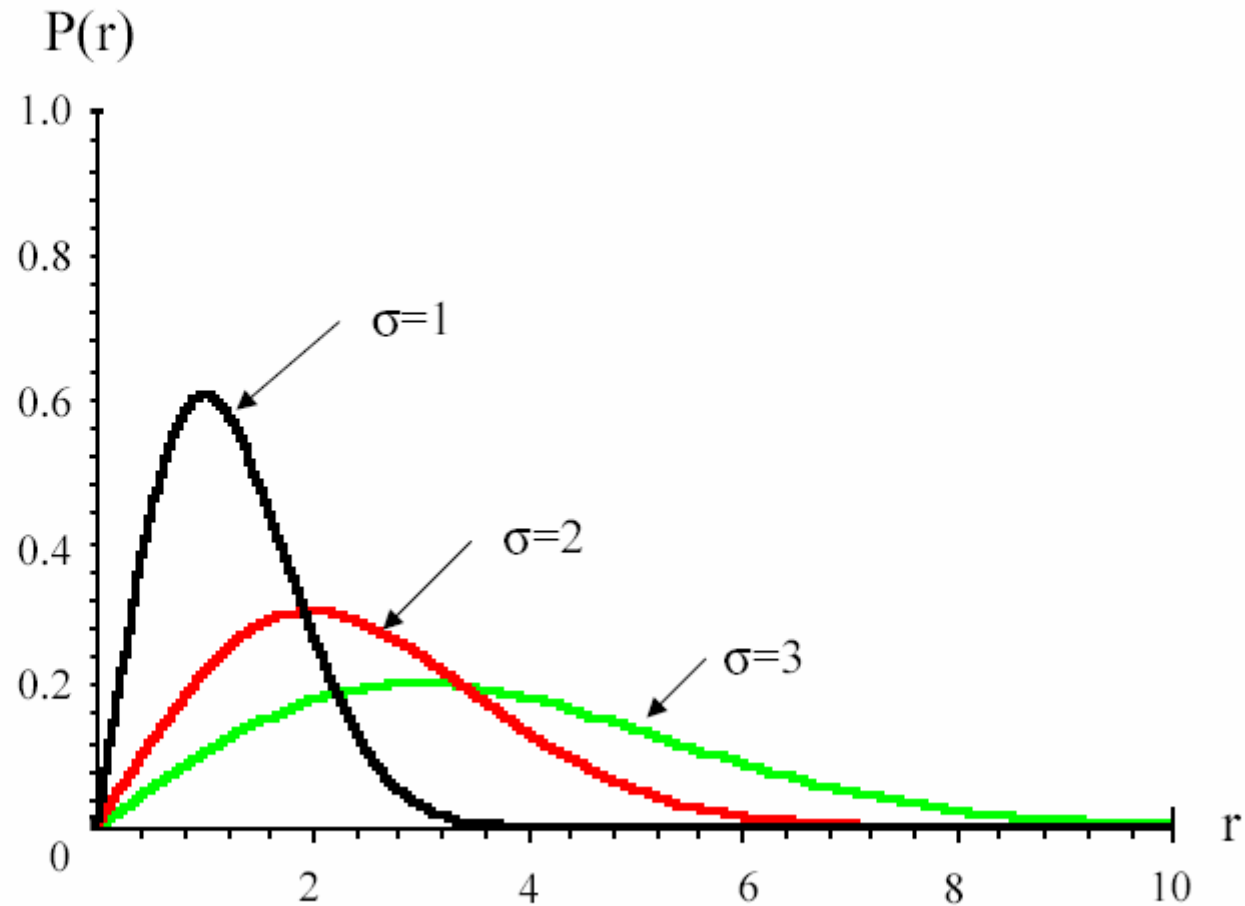

The pdf of the envelope variation



Rician Distribution

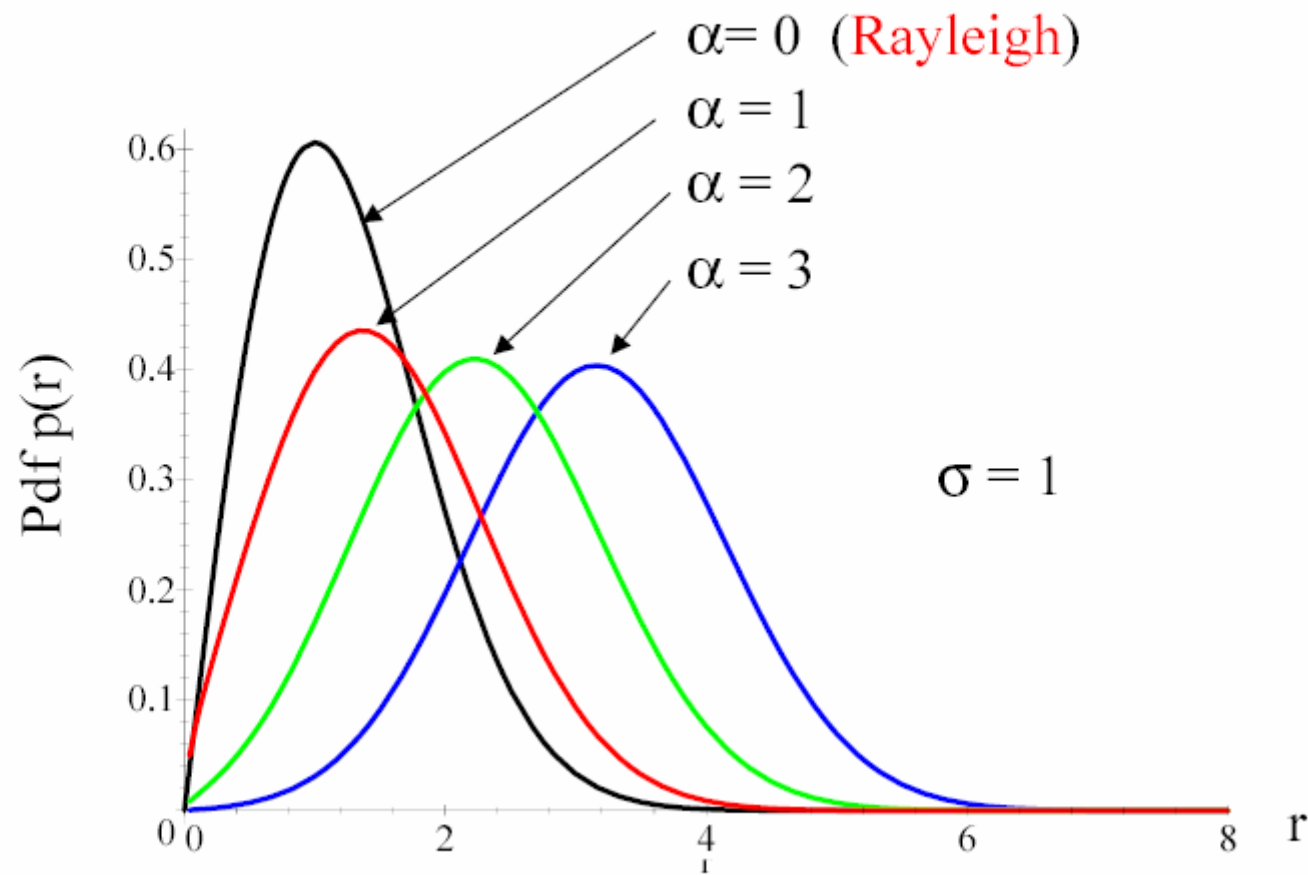

The pdf of the envelope variation

Delay Spread

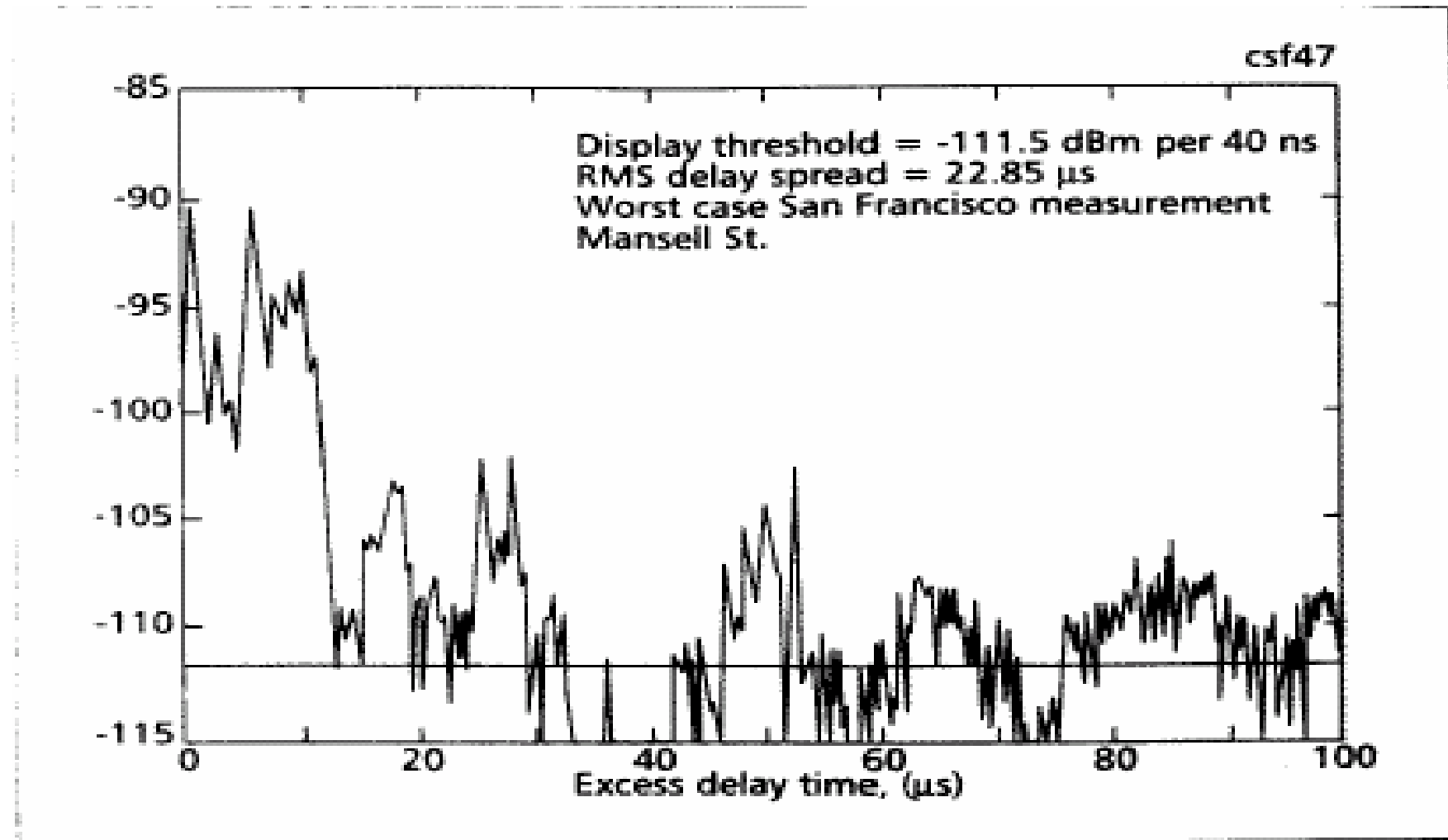



Delay Spread

- When a signal propagates from a transmitter to a receiver, signal suffers one or more reflections.
- This forces signal to follow different paths.
- Each path has different path length, so the time of arrival for each path is different.
- This effect which spreads out the signal is called “Delay Spread”.

Delay Spread

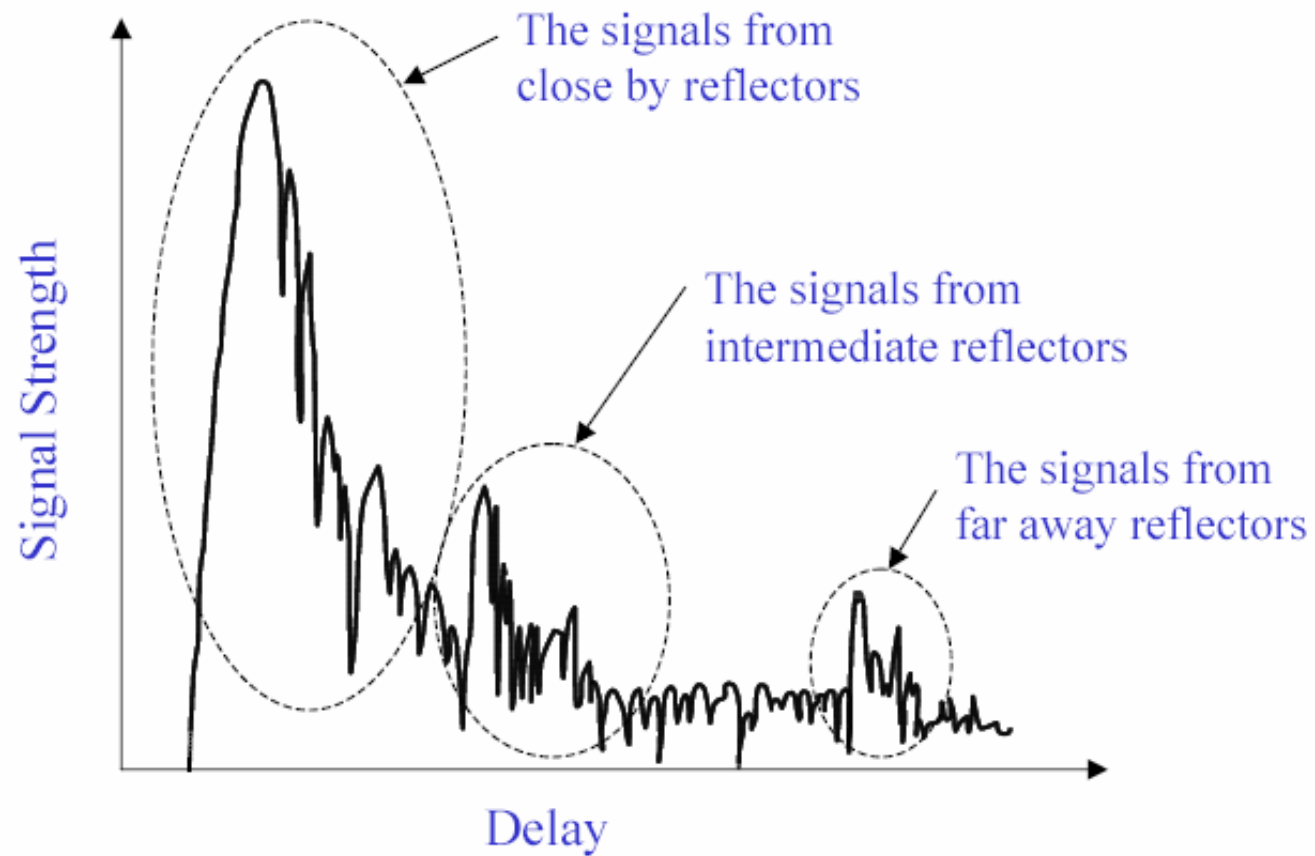



Intersymbol Interference (ISI)

- Caused by time delayed multipath signals
- Has impact on burst error rate of channel
- Second multipath is delayed and is received during next symbol
- For low bit-error-rate (BER)

$$R < \frac{1}{2\tau_d}$$

- R (digital transmission rate) limited by delay spread.

Intersymbol Interference (ISI)

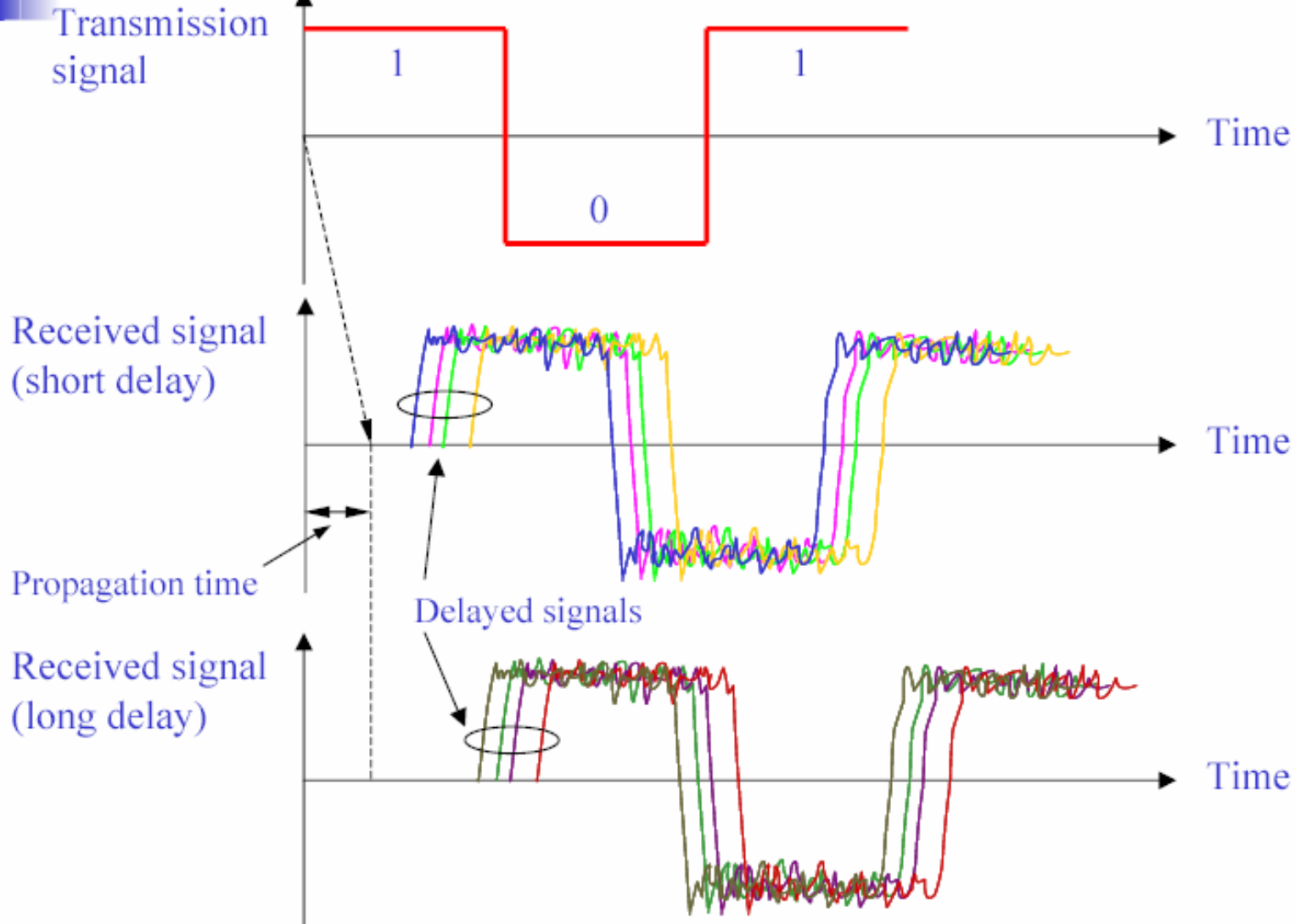

Coherence Bandwidth

- Coherence bandwidth B_c :
 - Represents correlation between 2 fading signal envelopes at frequencies f_1 and f_2 .
 - Is a function of delay spread.
 - Two frequencies that are larger than coherence bandwidth fade independently.
 - Concept useful in diversity reception
 - Multiple copies of same message are sent using different frequencies.

Parameters of a Multipath Channel

- ◆ Multipath Channel Impulse Response (measured by sounding technique)

$$h(t) = \sum_{i=1}^N a_i e^{j\theta_i} \delta(t - \tau_i)$$

- ◆ Four important parameters of interest

- RMS delay spread

$$\sigma_\tau = \sqrt{\overline{\tau^2} - (\overline{\tau})^2}, \overline{\tau} = \sum_k a_k^2 \tau_k / \sum_k a_k^2, \overline{\tau^2} = \sum_k a_k^2 \tau_k^2 / \sum_k a_k^2$$

- Coherence bandwidth

$$B_c = \frac{1}{5\sigma_\tau}$$

- Doppler spread

$$B_D = f_m = \max((v/\lambda) \cos \theta) = (v/c) f_{carrier}$$

- Coherence time

$$T_c = 0.423 / f_m$$

Doppler Shift

- Doppler Effect: When a wave source and a receiver are moving towards each other, the frequency of the received signal will not be the same as the source.
 - When they are moving toward each other, the frequency of the received signal is higher than the source.
 - When they are opposing each other, the frequency decreases.

Thus, the frequency of the received signal is

$$f_R = f_C - f_D$$

where f_C is the frequency of source carrier,

f_D is the Doppler frequency.

- Doppler Shift in frequency:

$$f_D = \frac{v}{\lambda} \cos\theta$$

where v is the moving speed,

λ is the wavelength of carrier.

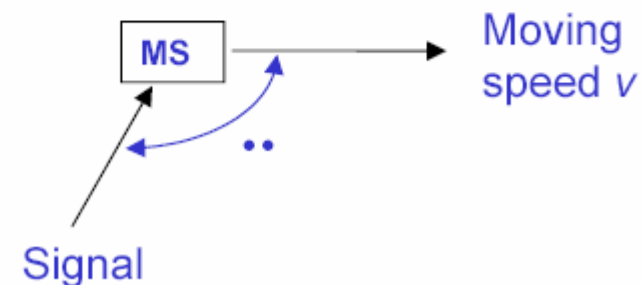

Types of Fading

- ◆ Two independent mechanisms:
 - Time Dispersion (Due to Multi-path delays)
 - ◆ Flat fading
 - ◆ Frequency Selective Fading
 - Doppler Spread (due to Motion of mobile or channel)
 - ◆ Fast Fading
 - ◆ Slow Fading

Fades: Why do we care?

- ◆ Data Rate
- ◆ Equalization
- ◆ Fades result in “Error Bursts”
- ◆ Average duration of (Flat) fades
- ◆ Depends primarily on speed of the mobile.

The Design of Wireless Modem



Combating Errors

- ◆ Increase transmitted power
- ◆ (Adaptive) Equalization
- ◆ Antenna or space diversity for “Multipath”
- ◆ Forward error correction
- ◆ Automatic Repeat Request (ARQ)

Direct Sequence Spread Spectrum

To transmit a 0 the station use a unique “chip sequence”:

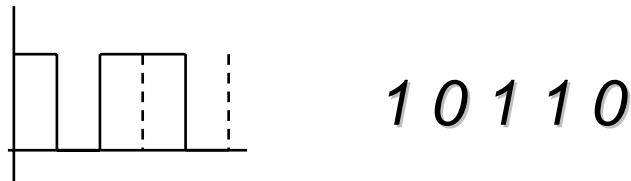

To transmit a 1 the station use the one’s complement of its chip sequence:



Therefore if data is 1010 it will transmit:

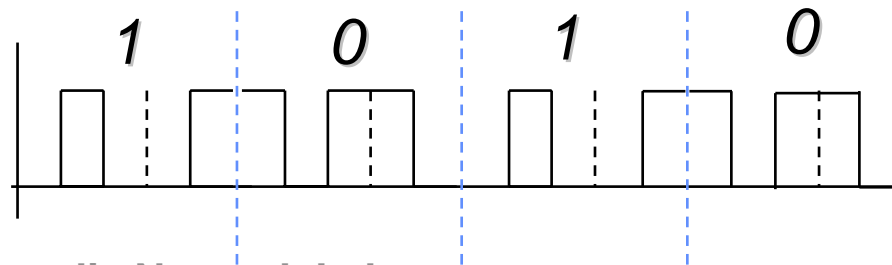

Frequency Hopping Spread Spectrum

- ◆ Transmitted signal is spread over a wide range of frequencies. (i.e. 2.400-2.485 GHz)
- ◆ Transmission usually hop 35 times per second.

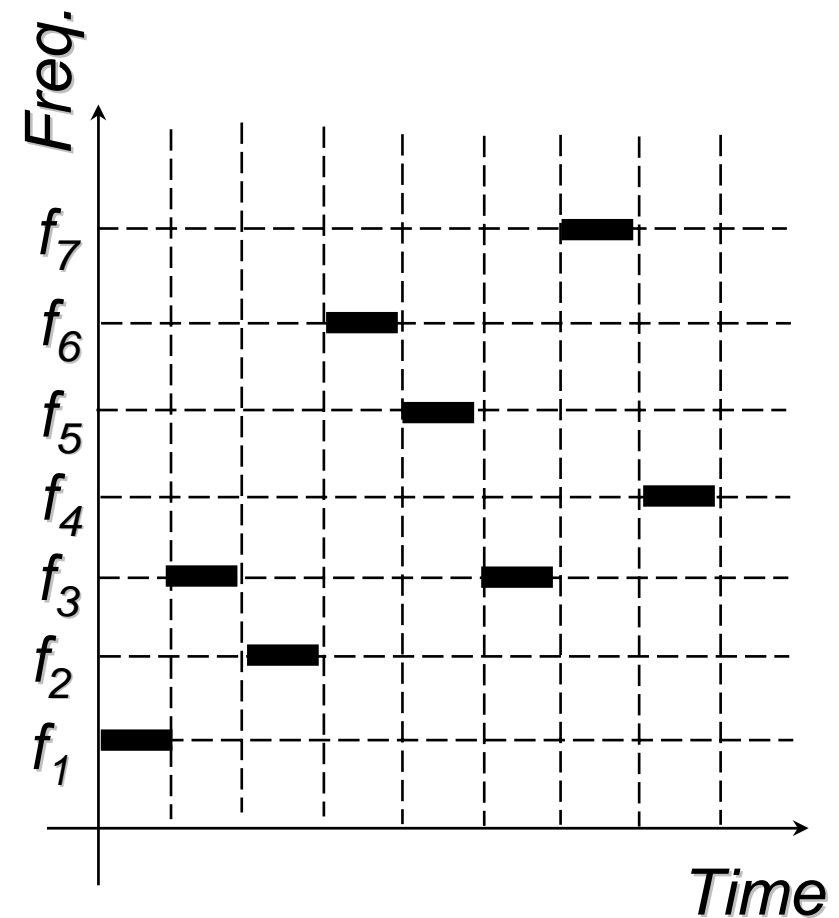

Antenna Types



- *Omni Directional Antenna*



- ◆ YAGI Directional Antenna

Modern Applications: 911 Service



Location Service

E-911 Requirement for Location Service

- ◆ 1996, FCC (Federal Communications Commission) announced its mandate for enhanced emergency services for cellular phone callers.
- ◆ The current deadline for this capability is October 1, 2001



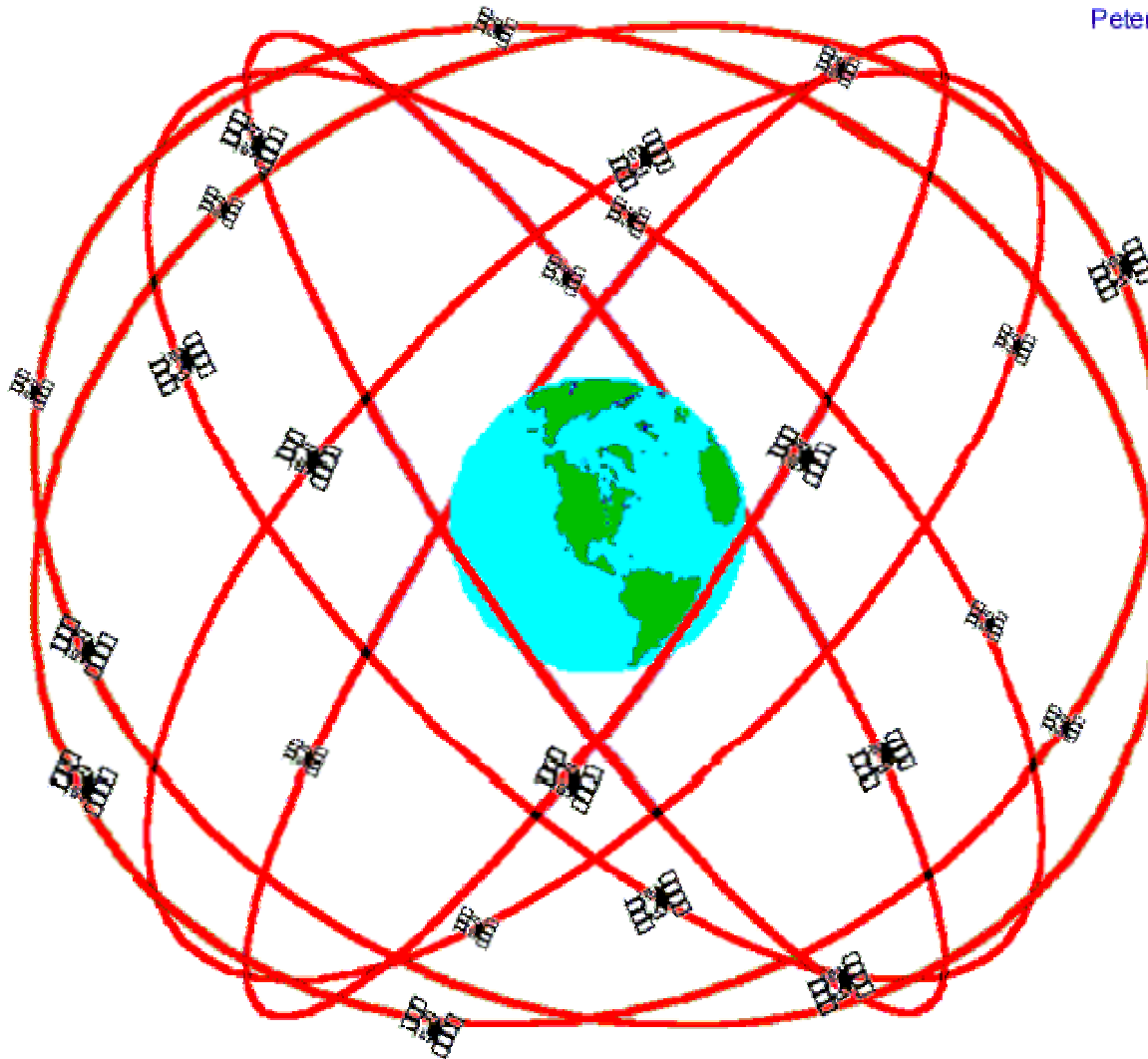

GPS Nominal Constellation
24 Satellites in 6 Orbital Planes
4 Satellites in each Plane

20,200 km Altitudes, 55 Degree Inclination

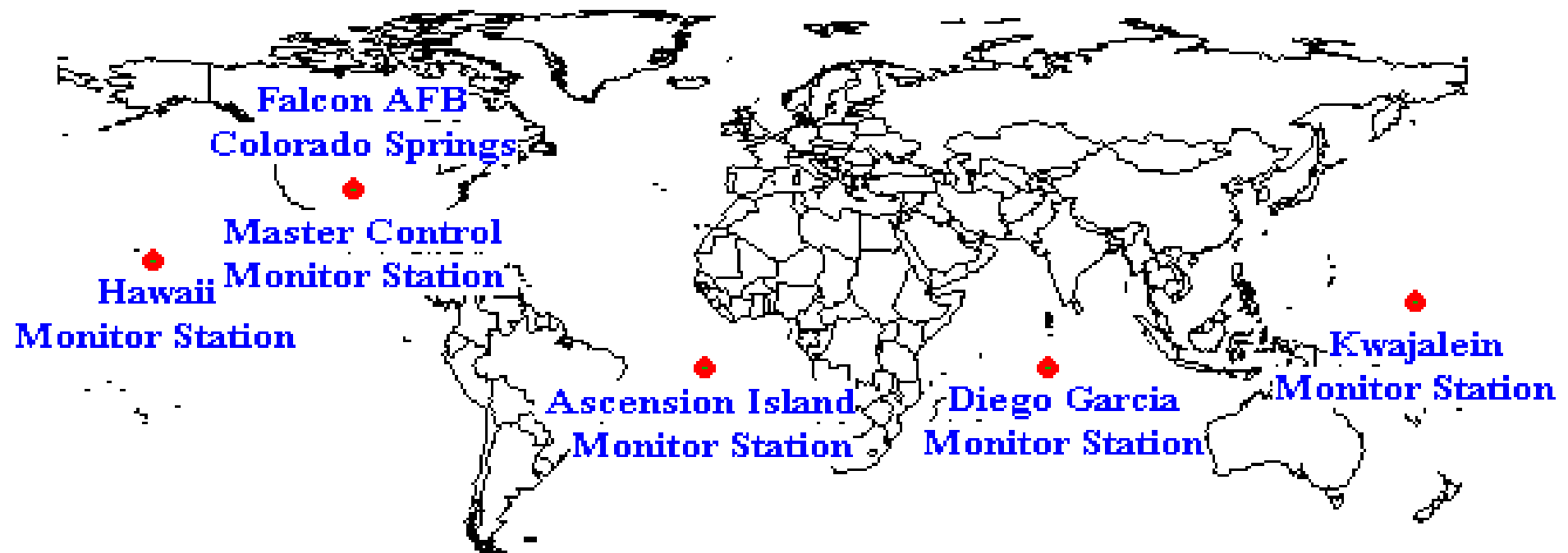

Global Positioning System (GPS) Master Control and Monitor Station Network

GPS (cont.)

◆ Position location

- 3-D 座標 (x,y,z) 需要3個獨立方程式可解.
- 三個GPS衛星得到三個距離量度，可設定所需的三個方程式.
- 需要第四個衛星來求得另一距離量度以建立第四個方程式 (T_{error})
- 這樣就可定位出他的位置
- With accuracy of approximately 100 m.

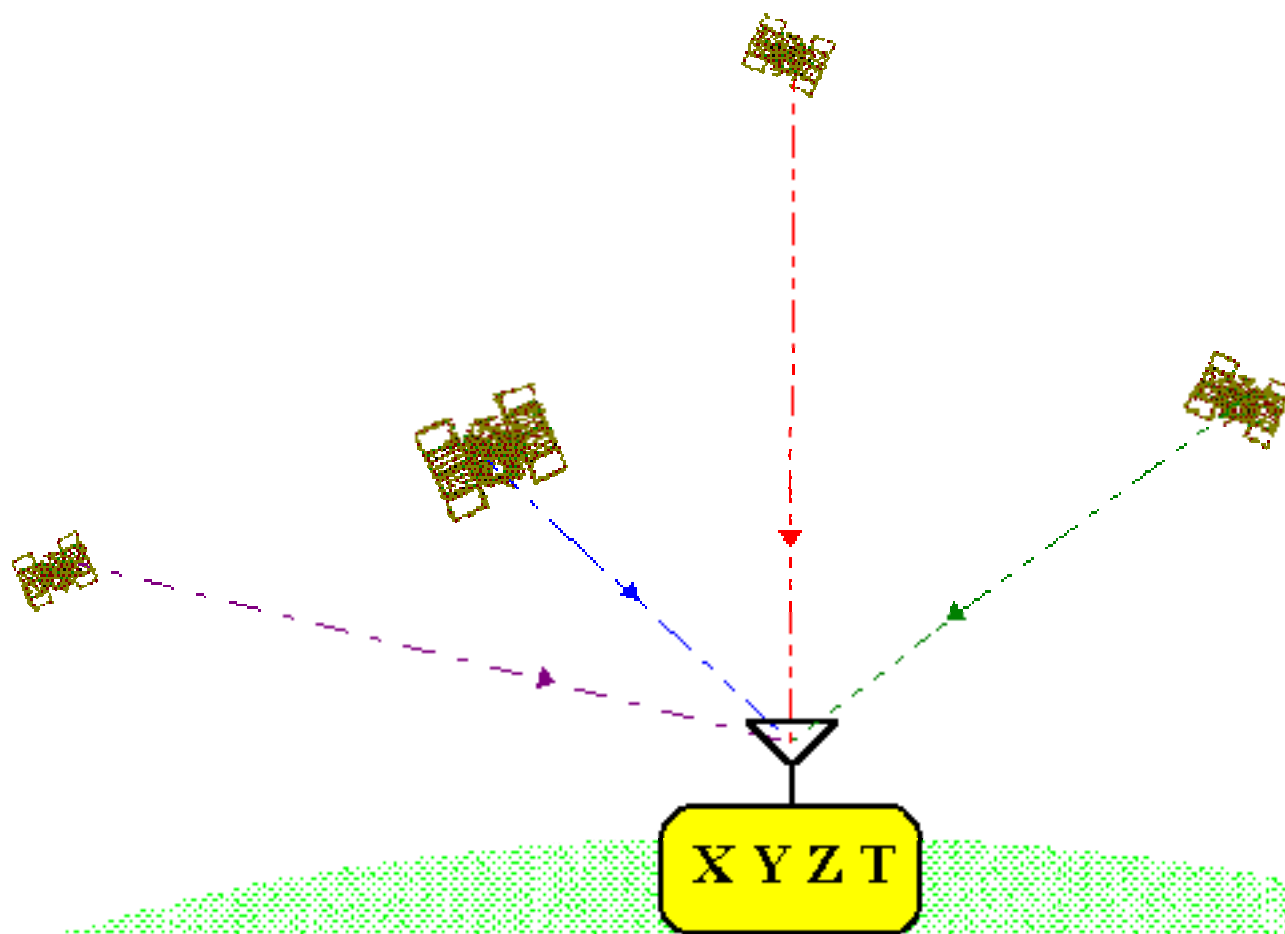

The Global Positioning System
Measurements of code-phase arrival times from at least four satellites are used to estimate four quantities: position in three dimensions (X, Y, Z) and GPS time (T).

Introduction

- ◆ Safety is the primary motivation for vehicle position location.
- ◆ Landline telephone companies to provide 911 emergency service .
- ◆ 1994, begin investigating similar service for U.S cellular and PCS providers.
- ◆ E-911 service include caller's ANI and street address information.

Mobile Location Solution

Driving Force :

Legal aspects :

- Fire brigades, hospitals and other emergency centers.

Commercial aspects :

- Differentiation : new and attractive services.
- Reduced costs : operators can adapt their network to match calling patterns.
- Increased revenues : commercial services that use positioning information is infinite.

Positioning mechanism and requirement

Terminal-based :

- Positioning intelligence is stored in the terminal or its SIM card.
- Network-assisted global positioning system (A-GPS).

Network-based :

- Positioning intelligence isn't built into the handset.
- Measurement of Cell global identity and timing advance (CGI+TA) 、 uplink time of arrival (UL-TOA).

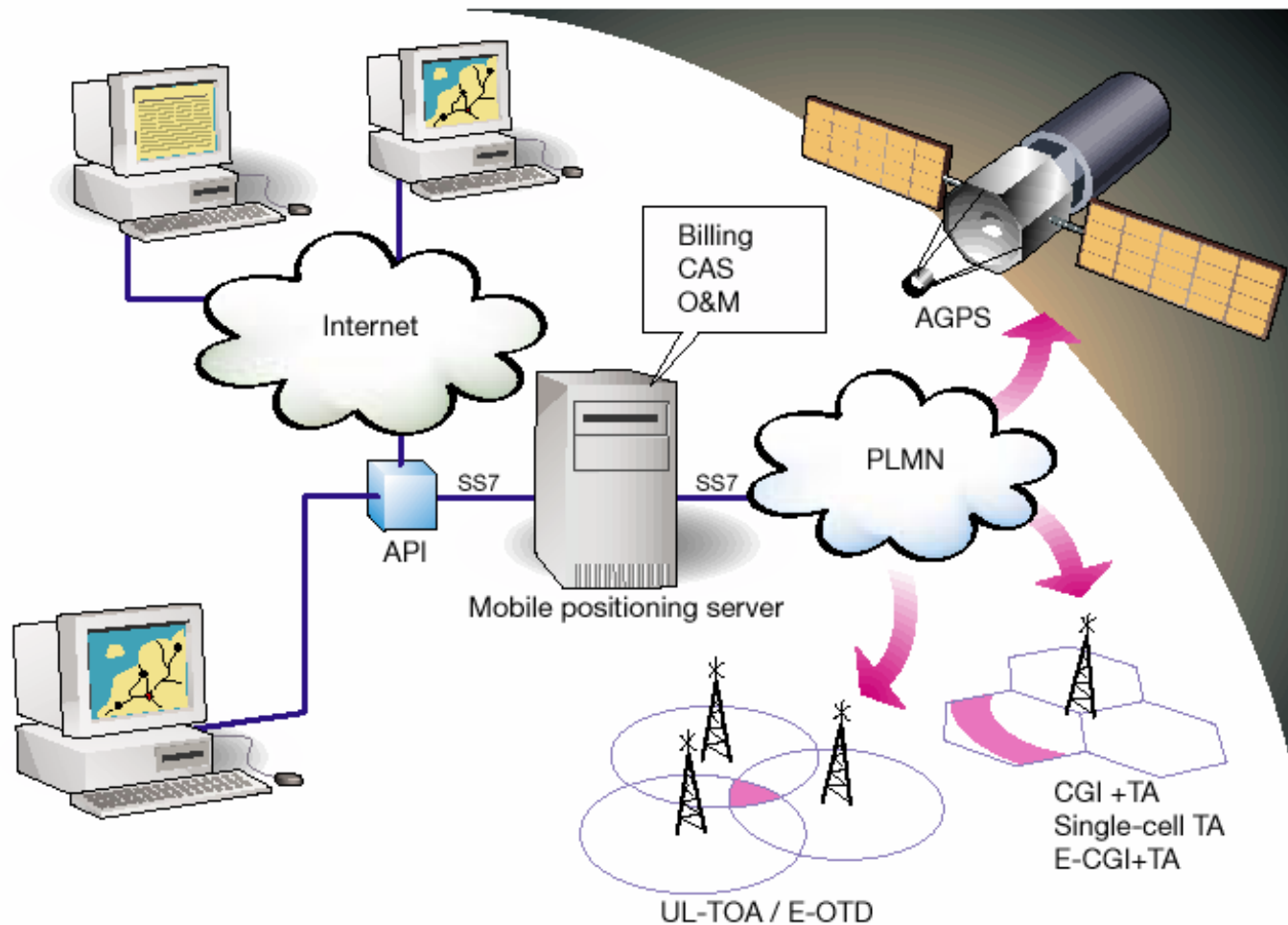

Mobile location solution has been designed to handle a variety of positioning methods and application interfaces.

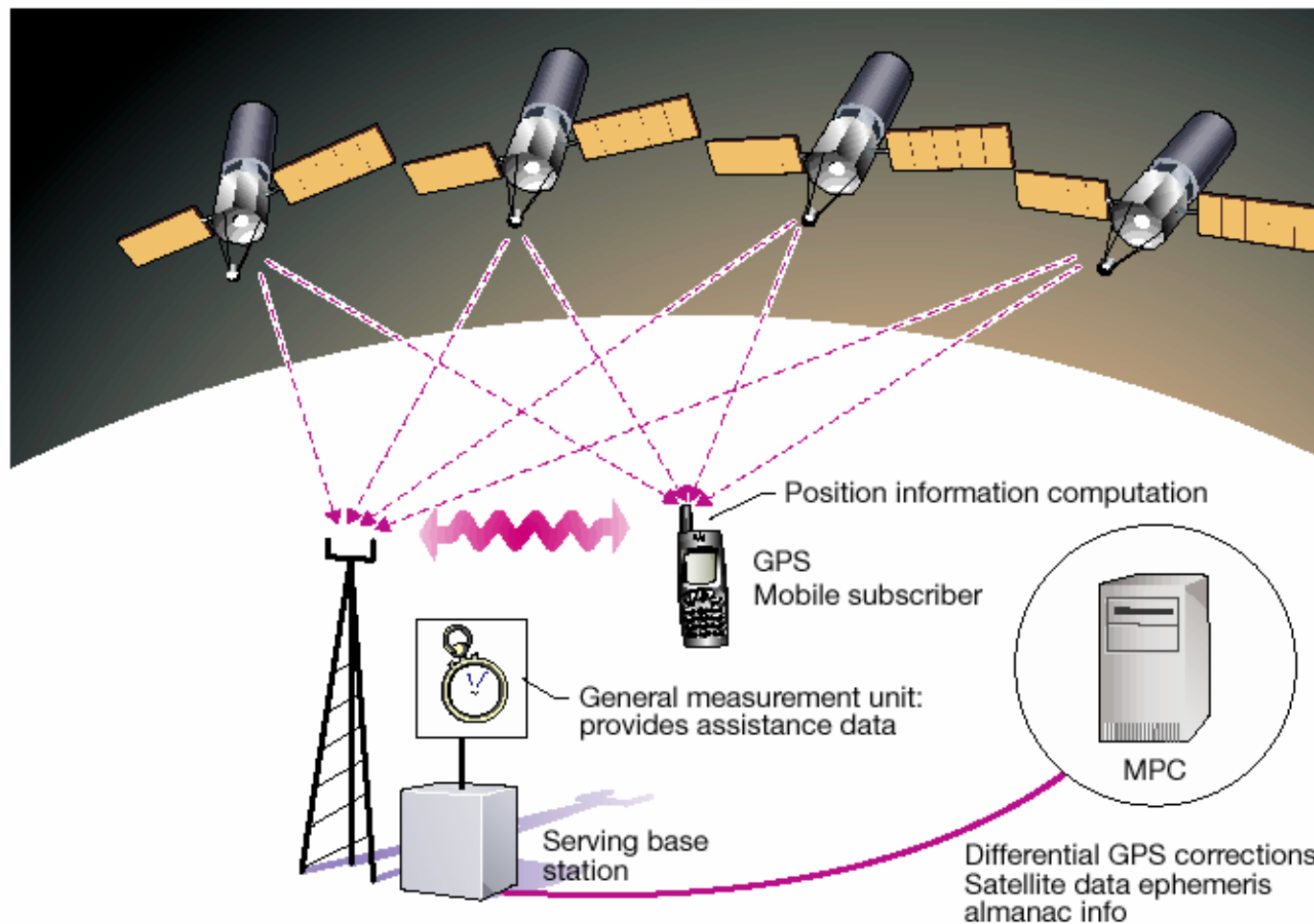

Network-assisted GPS (A-GPS) is a positioning product with very attractive characteristics.

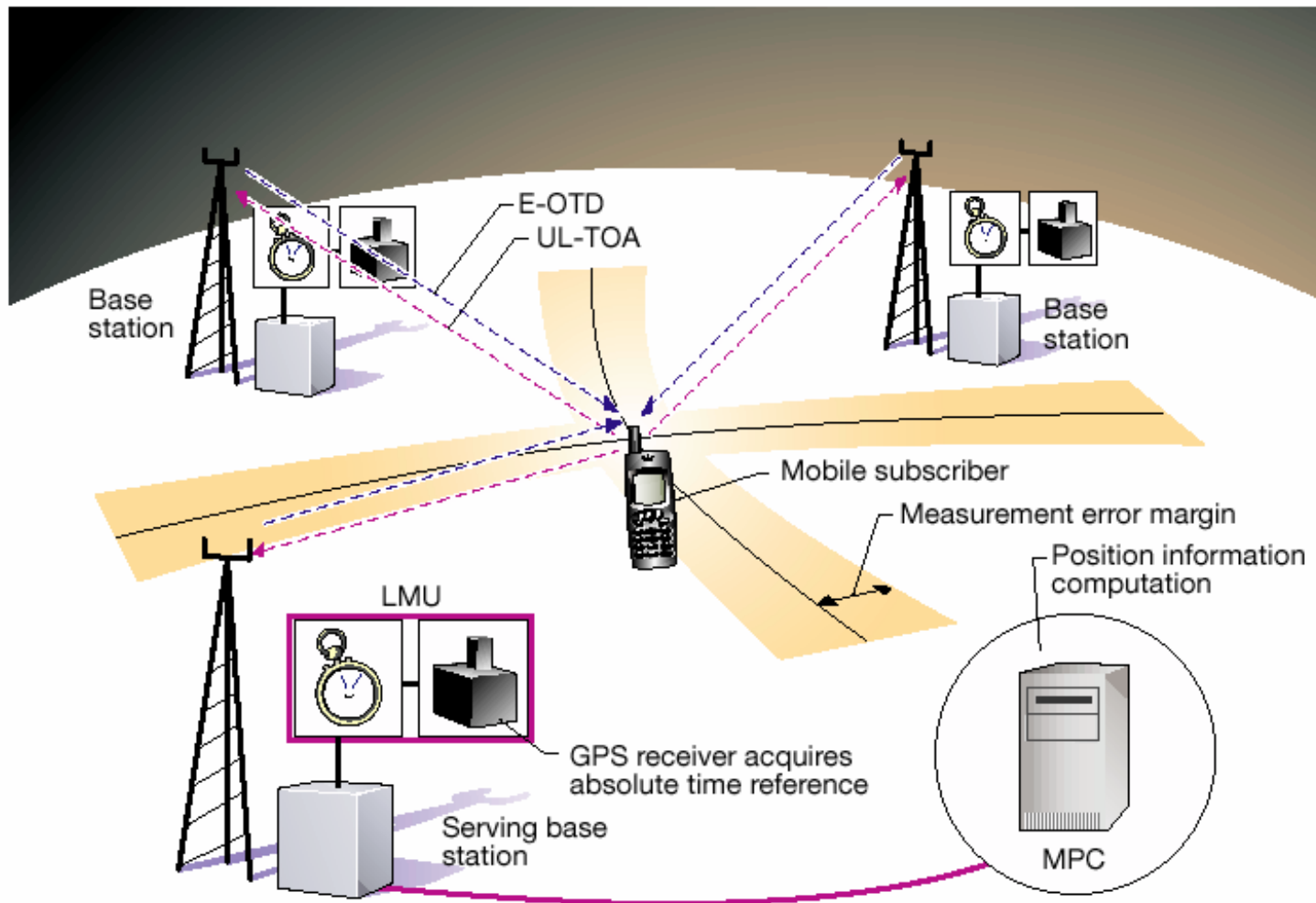

UL-TOA and E-OTD methods each use the triangulation of time difference between base stations and the terminal to determine positions.

Location applications

Information services :

- Location-based yellow pages, events, and attractions (ex. What is happening today in town near here?) .

Tracing services :

- Tracing of a stolen car, helping paramedics to locate persons quickly in an emergency situation, and giving a towing service or automobile repair shop the location of a motorist in need (out of gas, flat tire, dead battery).

Location applications (cont.)

Resource management :

- Taxi fleet management, the administration of container goods, and the assignment and grouping of railway repairmen.

Navigation :

- Vehicle or pedestrian navigation.

Small Scale Fading

- ◆ Mean Excess Delay, rms delay spread

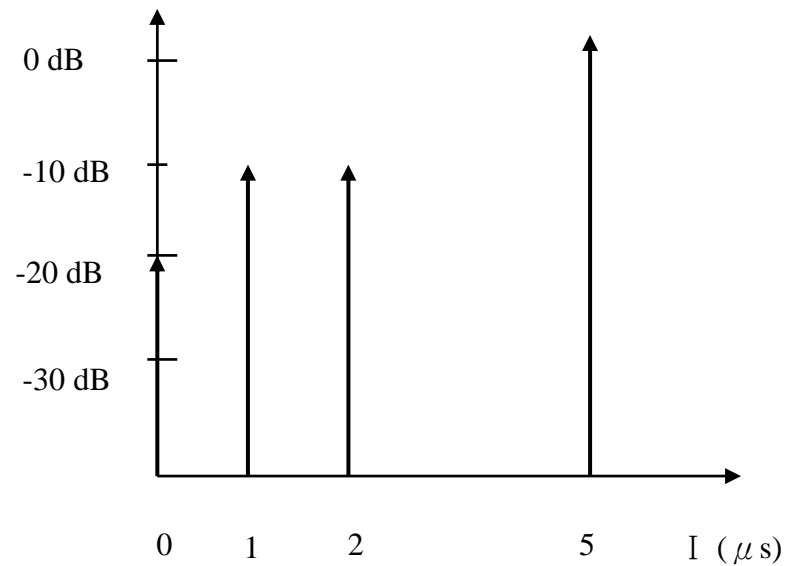

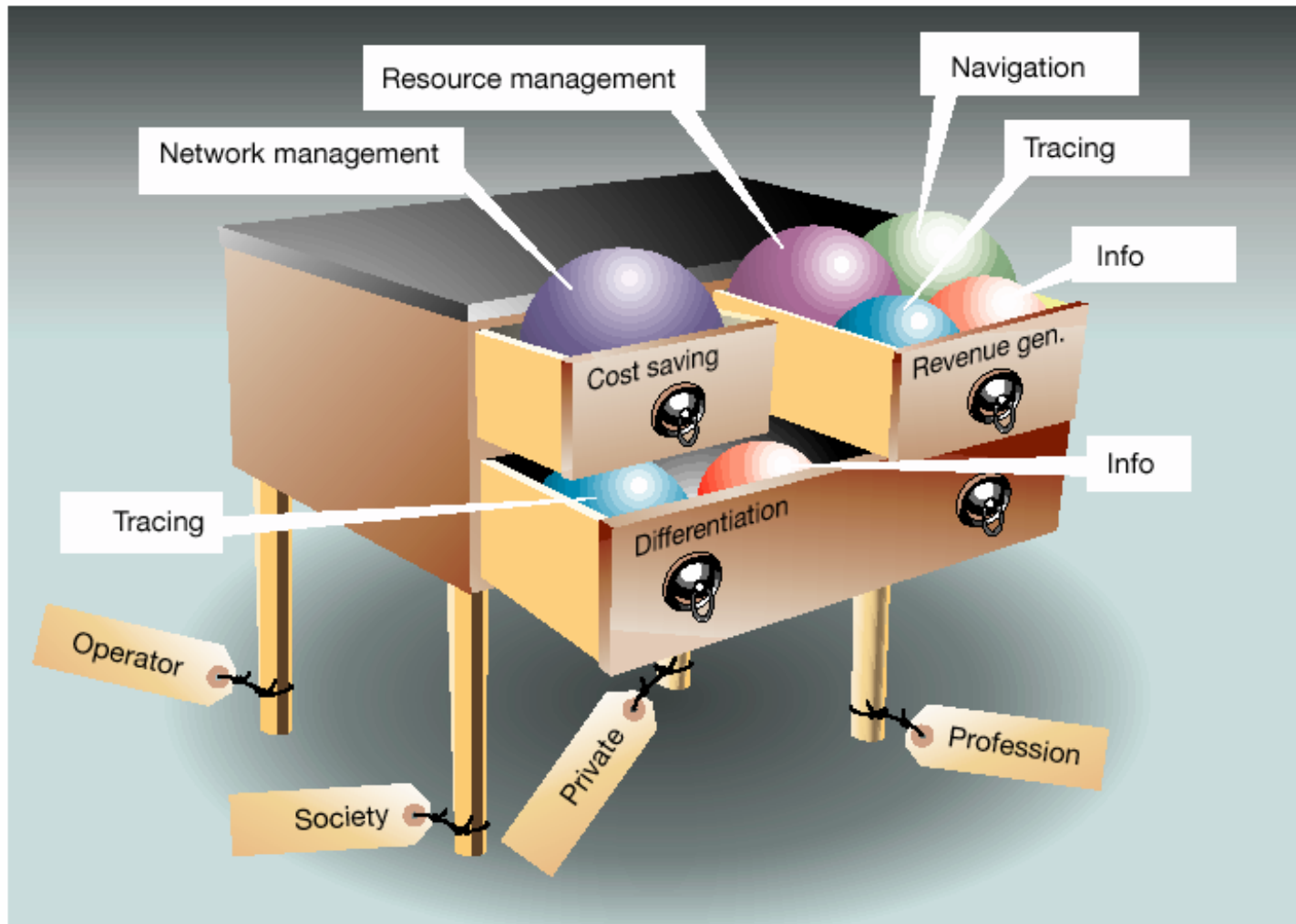

The chest of drawers illustrates how different applications can be grouped strategically for use by their beneficiaries.

Channel Propagation and Fading

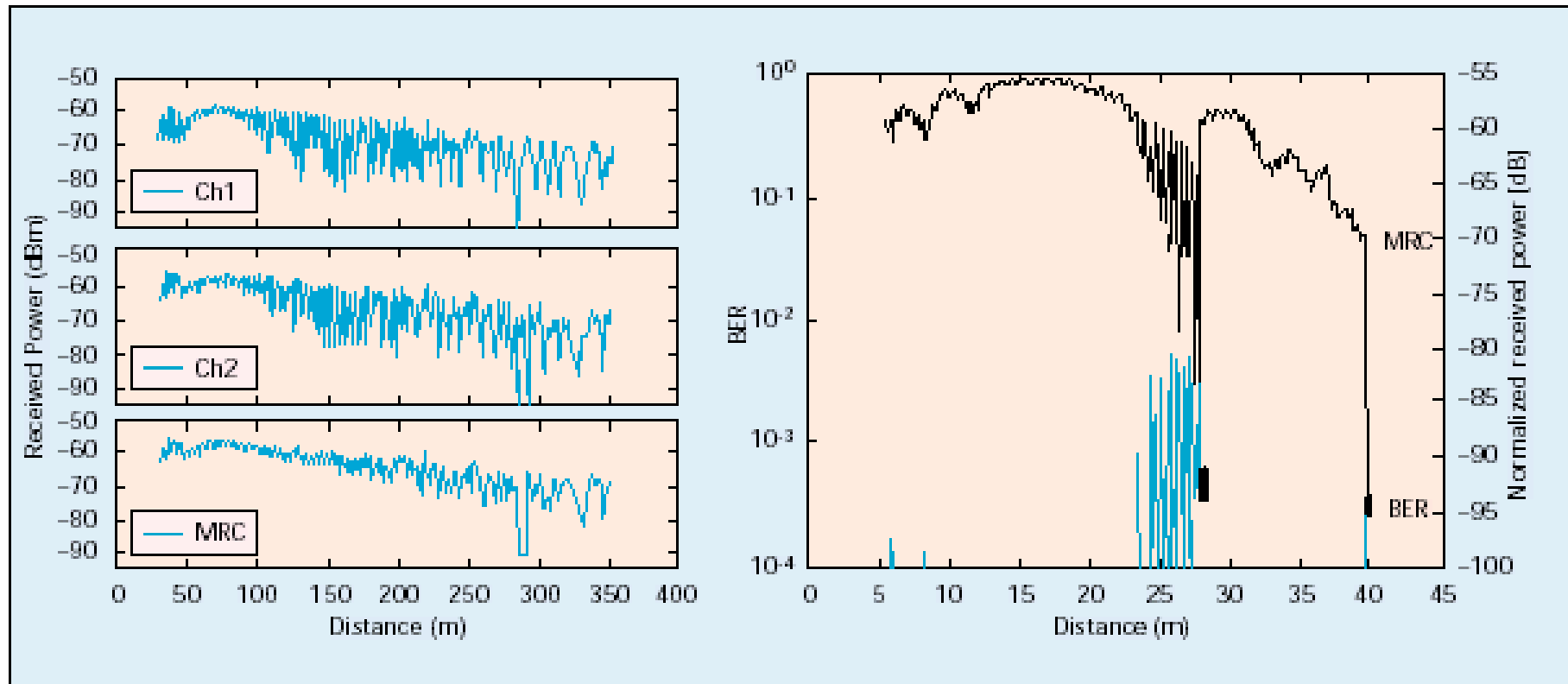

■ Figure 4. Received power as a function of distance: in a street (left), in a pavilion (right); BER and handover (right).