

# 無線網路多媒體系統

## Wireless Multimedia System

### (Topic 3)

Wireless Link I: Fundamental issues of Modulation  
and Multiple Access

中央大學 吳曉光博士

<http://wmlab.csie.ncu.edu.tw/course/wms>

無線網路多媒體實驗室  
Wireless Network & Multimedia Laboratory  
We provide Wireless Solutions

# How to deal with Radio Propagation

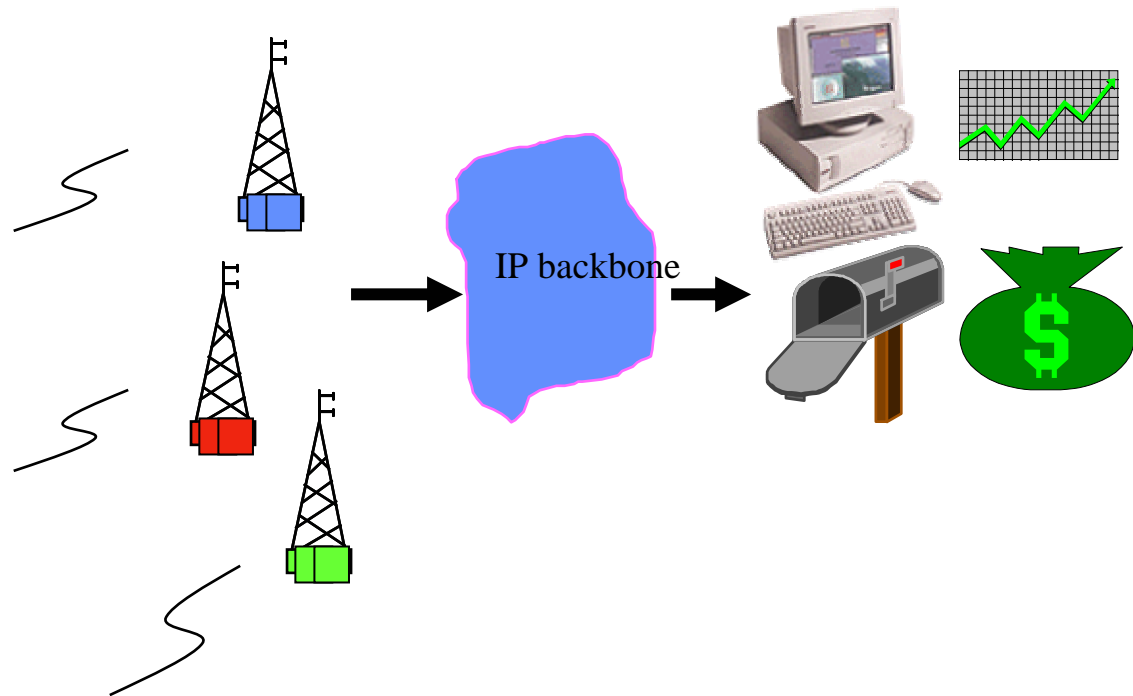

# Where are you from?

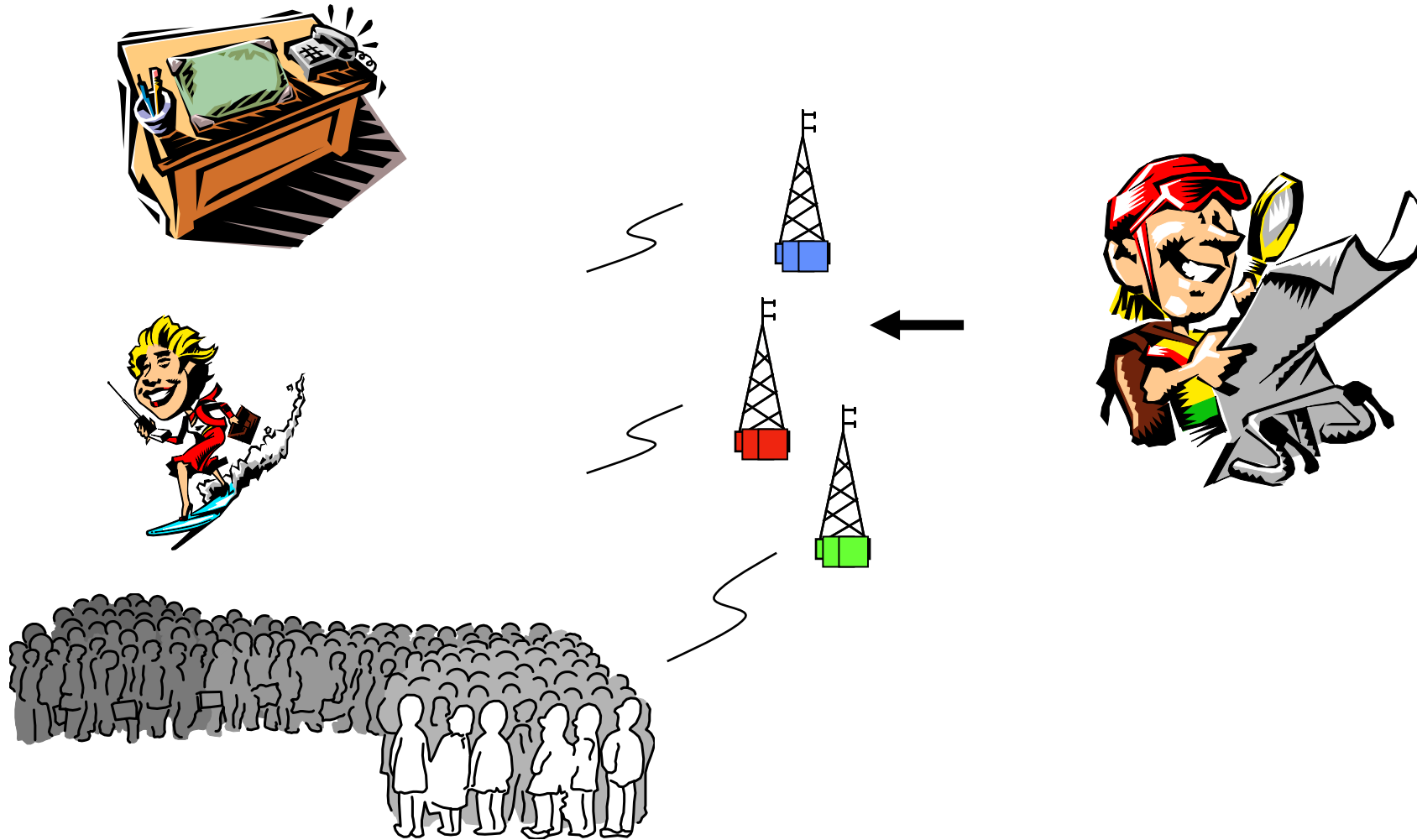

# QoS and Multimedia Traffic Support

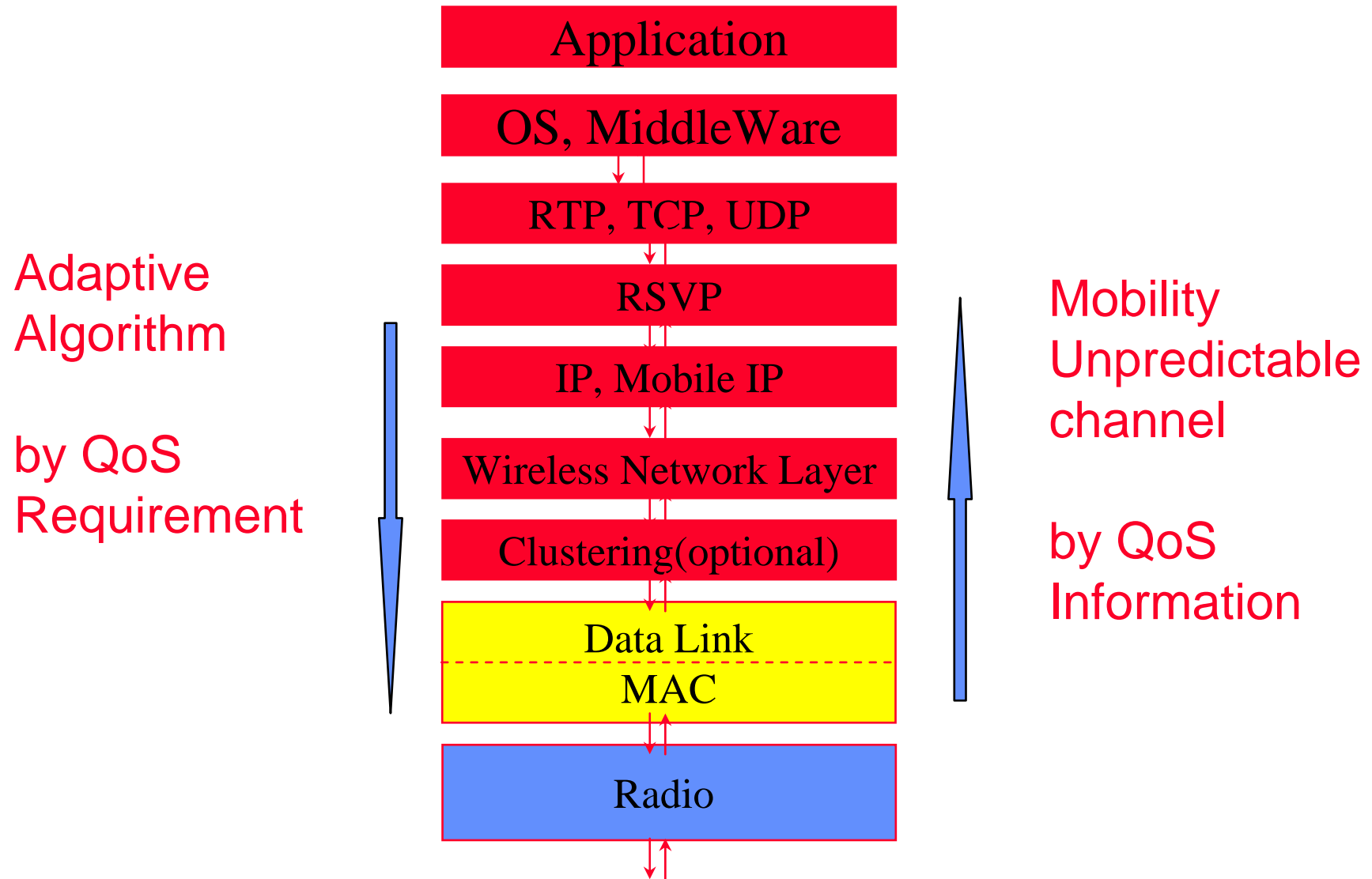

# Multiple Access & Modulation

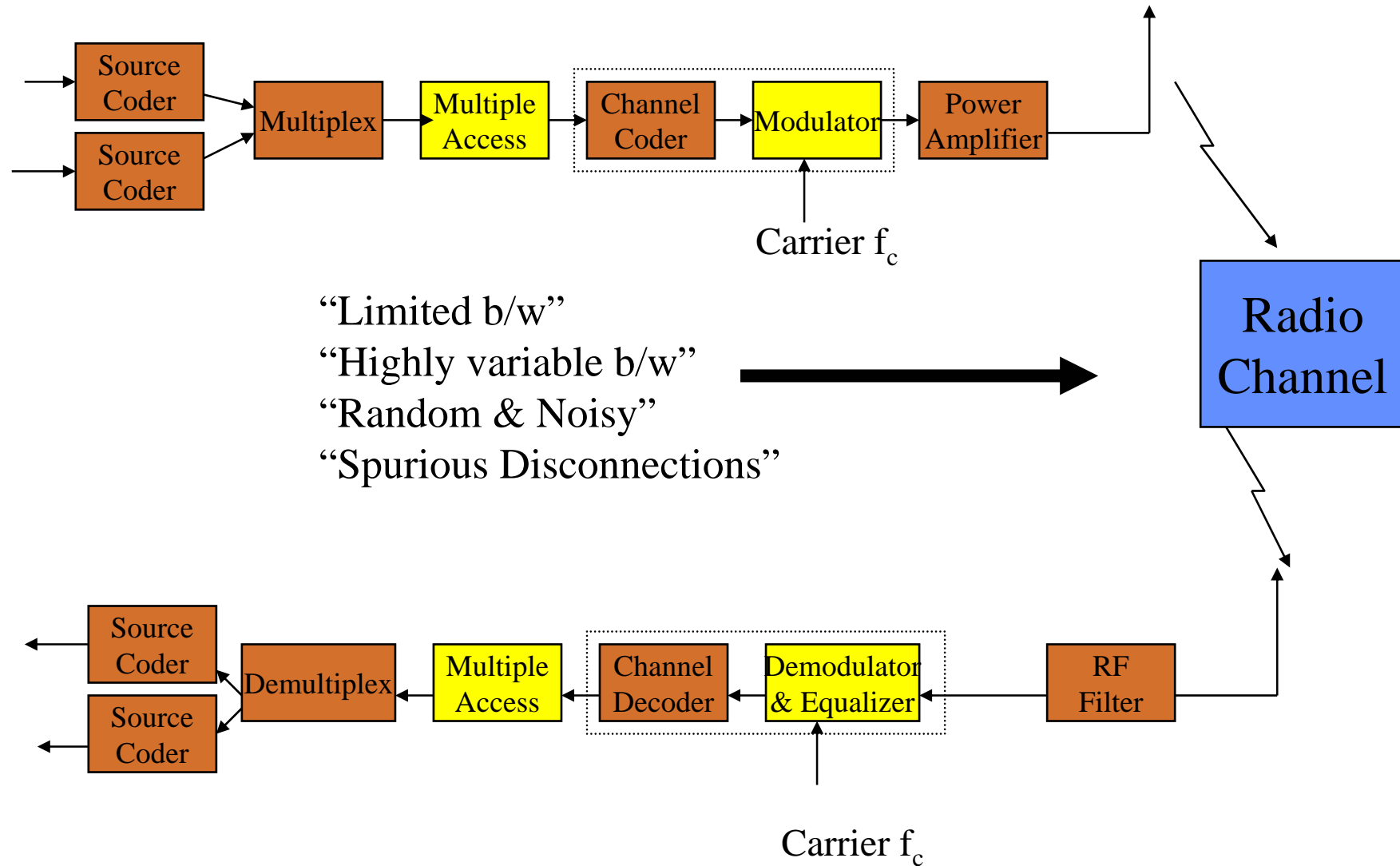

# Topic III Agenda

## ◆ Wireless Link

- Deployment of “Pervasive Computing” and “Seamless Telecom services”
- Channel resource sharing in time, frequency, and code dimensions
- Spread Spectrum-direct sequence, frequency hopping, interference resistance
- Static techniques: TDMA, FDMA, CDMA
- Random access techniques: MACA, MACAW, 802.11 etc



# What kind of multiple access environments?

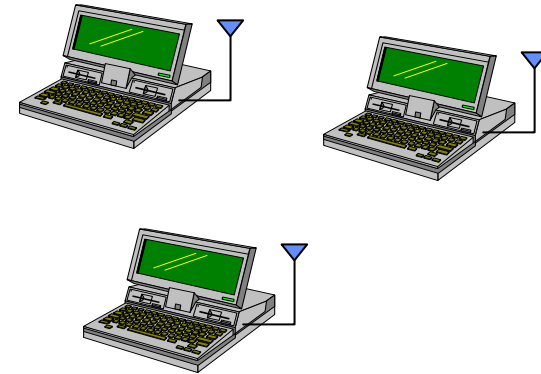

## Reading list for This Lecture

### ◆ Required Reading:

- (David 95) David D. Falconer, F. Adachi, and B. Gudmundson, "Time Division Multiple Access Methods for Wireless Personal Communications", IEEE Communication Magazine January 1995
- (Bharghavan94) V. Bharghavan, A. Demers, S. Shenker, L. Zhang, "MACAW: A Medium Access Protocol for Wireless LANs, Proceedings of SIGCOMM'94
- (J.J.97) L. Fullmer and J.J. Garcia-Luna-Aceves, Solutions to Hidden Terminal Problems in Wireless Networks, Proceedings of SIGCOMM'97
- ("Thomas 2000) Thomas, "Paving the Way for Personal Area Network Standards: An Overview of the IEEE P802.15 Working Group for Wireless Personal Area Networks", Personal Communications February 2000

### Further Reading

- (Vadu2000) Vaduvur Bharghavan, "Achieving MAC Layer Fairness in Wireless Packet Networks". IEEE MobileCom2000
- (Songwu Lu2000) Haiyun Luo, Songwu Lu, Vaduvur Bharghavan, "A New Model for Packet Scheduling in Multihop Wireless Networks". IEEE MobileCom2000
- (J.J.2001) L. Bao A New Approach to Channel Access Scheduling for Ad hoc Networks, IEEE MobileCom2001
- (Alex2001) A. Woo, David E. Culler, "A Transmission Control Scheme for Media Access in Sensor Networks", IEEE MobileCom2001
- (Gavin2001) G. Holland, N. Vaidya, P. Bahl, "A Rate-Adaptive MAC Protocol for Multi-Hop Wireless Network, IEEE MobileCom2001



# Pervasive Computing Projects



Packet Oriented -> Multimedia Traffic

# Smart Kindergarten (UCLA)

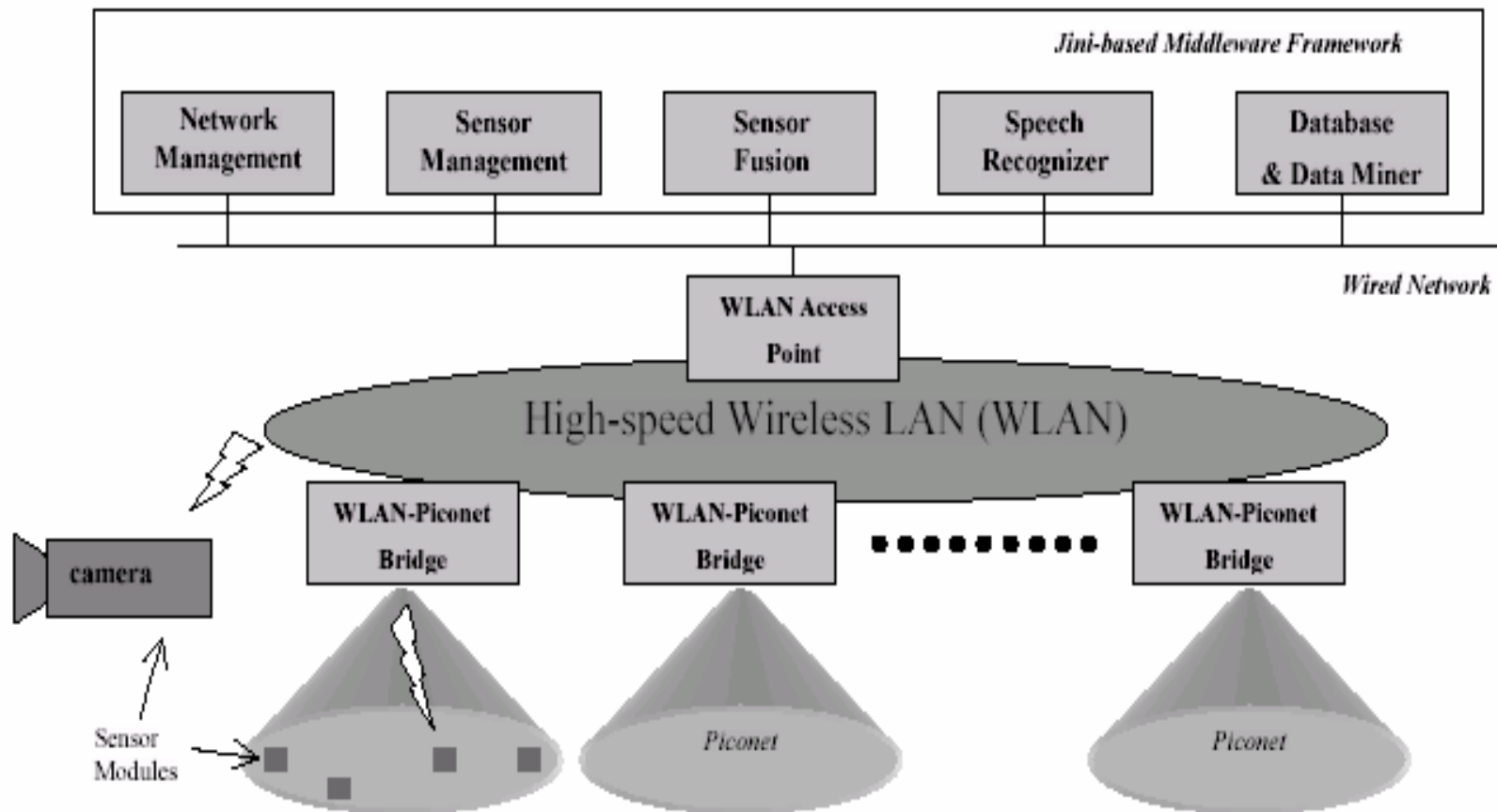

# Cricket Location-Support System (MIT)

- ◆ Beacon broadcast <-> Listeners
- ◆ Cricket Location-support system

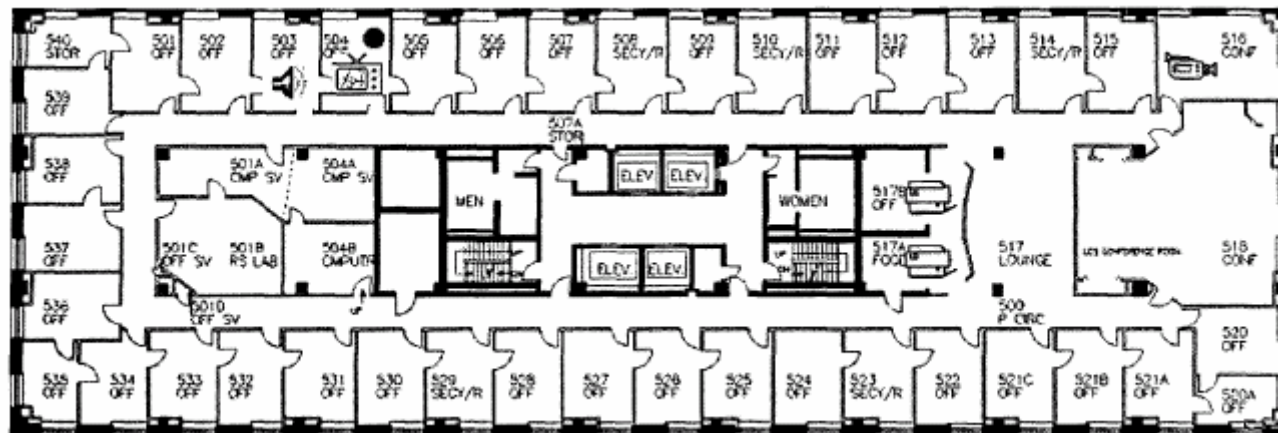

# Making Computer Disappear (Stanford) ADS (Appliance Data Services)

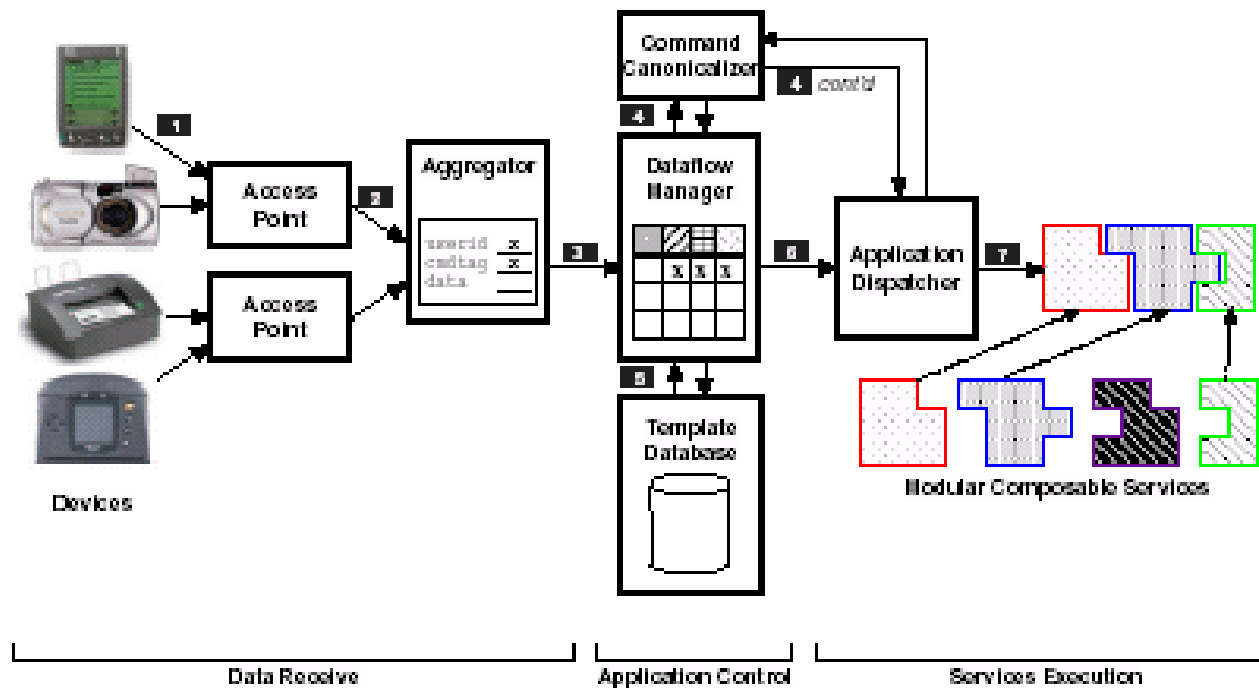

- 1 data sent to Access Point
- 2 Aggregator receives data, which completes the triple: (userid, cmdtag, data)
- 3 completed triple sent to Dataflow Manager
- 4 Canonicalizer converts cmdtag to plaintext
- 5 (userid, cmdtag) looked up in Template Database to find matching application template
- 6 application template and data sent to Application Dispatcher when required data is received
- 7 Application Dispatcher invokes services on data as specified in the application template

# M-Links (Xerox)

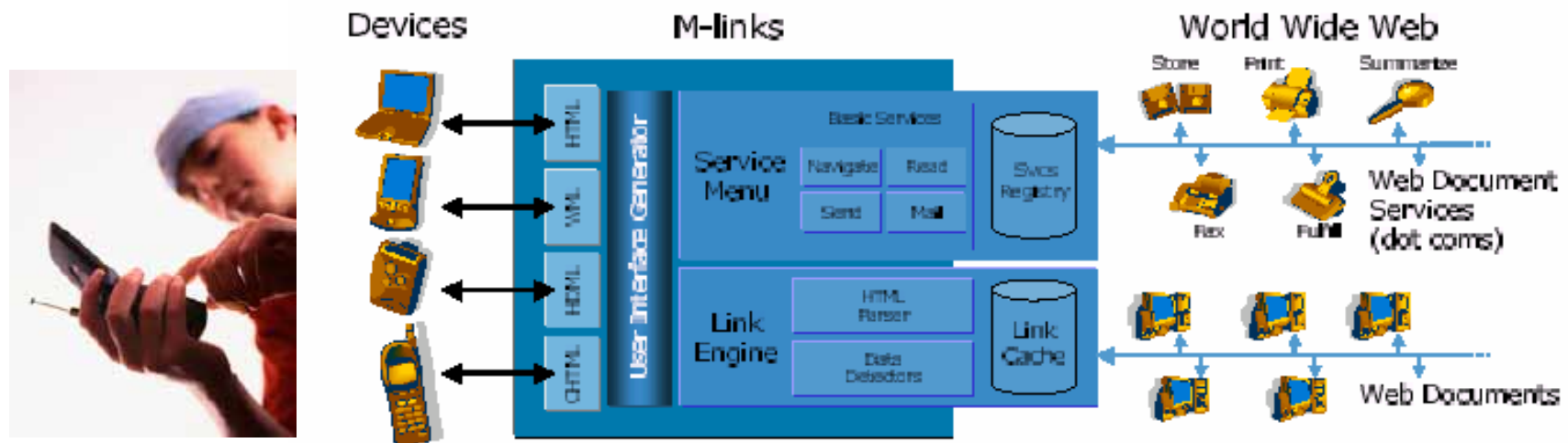

# Seamless Telecom Deployments



**Circuit Services-> Data Services -> Multimedia**

# 2.5 G & 3 G

Packet Radio



Packet Backbone

System Integration  
Multimedia Services  
Mobile Computing

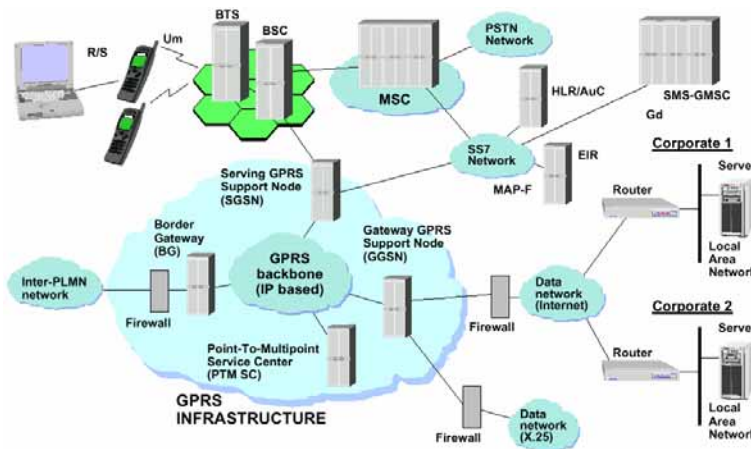

Network	Radio	Terminal	Interconnectivity
Servers (IP)	WAP	Applications • Multimedia • Infotainment	Bluetooth
Packet Networks	JAVA	User Interface	
IS-41, GSM MAP Evolution	3G Radio	EPOC 32 SWD Radio	

# Wireless Networking Technology



**Telecom & Datacom**

**Circuit & Packet**



# MAC Design Issues

- ◆ What kind of Resource we have?
- ◆ How much you need and how often and how regular you need?
- ◆ How often you will initial request?
- ◆ How much traffic you could afford?
- ◆ How much “Promise” you could provide?
- ◆ How fair you are going to be?
- ◆ Control or “Let it be”?
- ◆ Power Saving Issues?
- ◆ Complexity?



# Circuit Switch

- ◆ **Cellular System**
  - AMPS
  - GSM
- ◆ **Voice System**
  - Continue Traffic
- ◆ **Circuit Set up**
  - Reserve A trunk

# HOW about Data

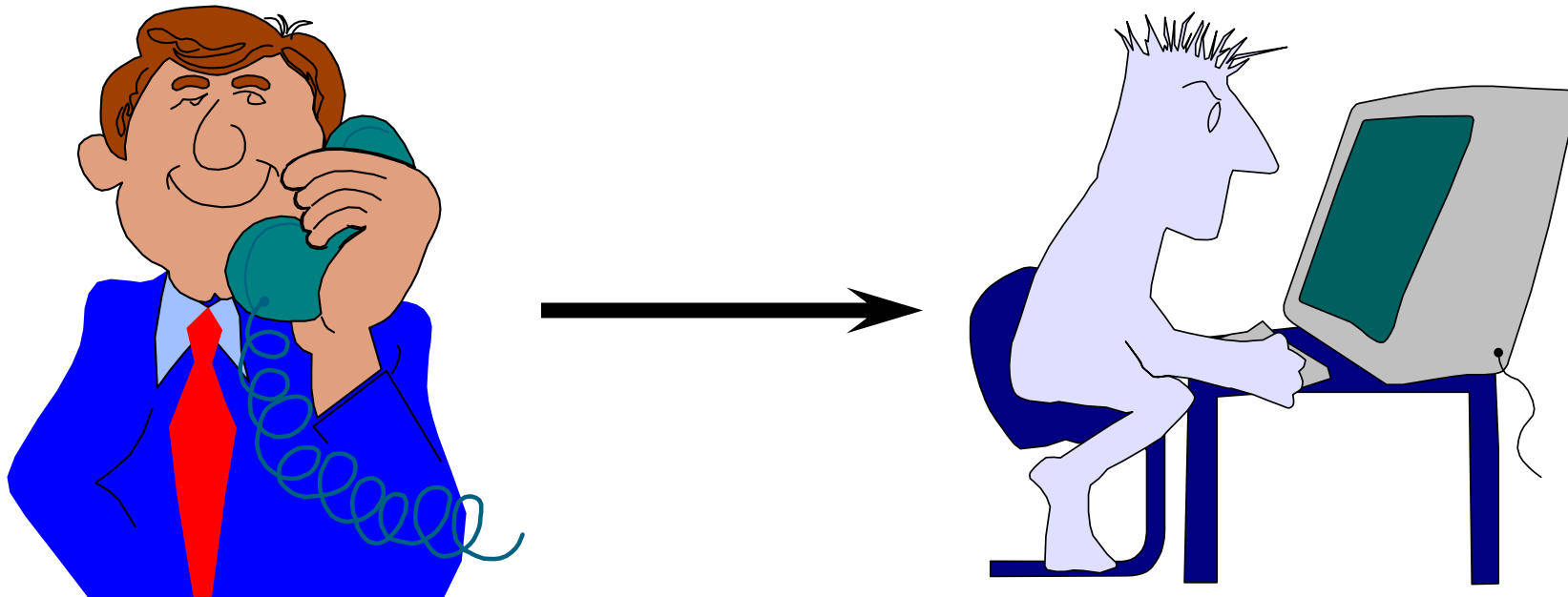

# Packet Radio

- ◆ **Packet Nature**
  - If we could deliver information by packet
  - Bursty Type of Traffic
  - Packet Size

# CSMA with Collision Detection/Avoidance

- ◆ **CSMA/CD: enhancement to slotted or unslotted CSMA schemes**
- ◆ **Node monitors its own transmission**
  - If collision detected, transmission is aborted without waiting for a NACK backoff and re-transmission procedure started
  - A jamming signal may be sent to get everybody else to abort too
- ◆ **Problem: does not work with RF wireless**
  - Cannot easily sense the channel while transmitting
    - ◆ MH's signal will dominate, need different receiving and transmitting antenna patterns
- ◆ **But, does work well with infrared wireless.. Directional receivers**
- ◆ **Wireless networks stick with ACK/NACK approach**
  - Popular called CSMA/CA
  - 802.11

# RANDOM Access

- ◆ Give everybody freedom



# Hawaii Story

- ◆ University of Hawaii
- ◆ ALOHA
  - Hello and Goodbye

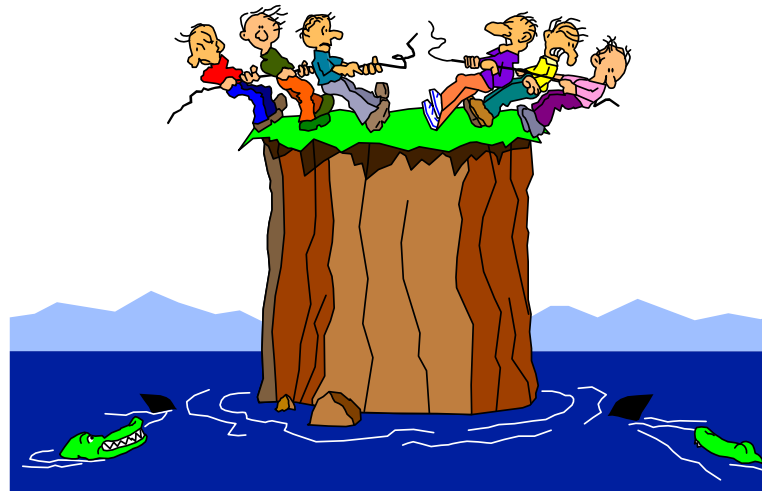

# Multiple Access

## ◆ Fundamental Problem

- How to share the Time-Frequency Space among multiple co-located transmitters?

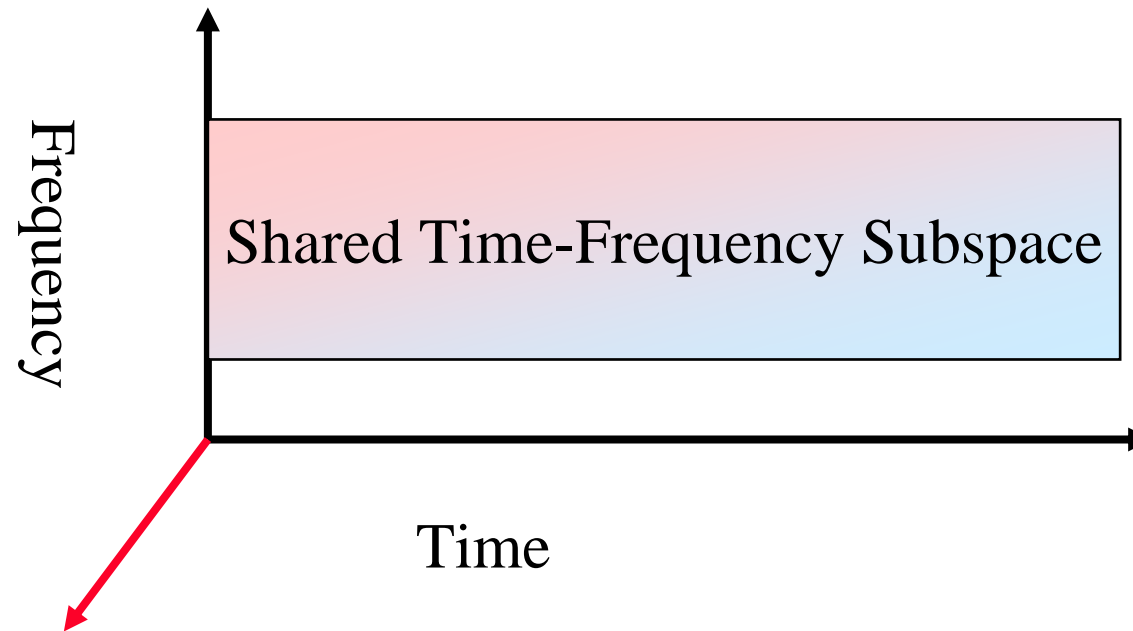

CDMA approach



# Base-station versus Peer-to-Peer Models

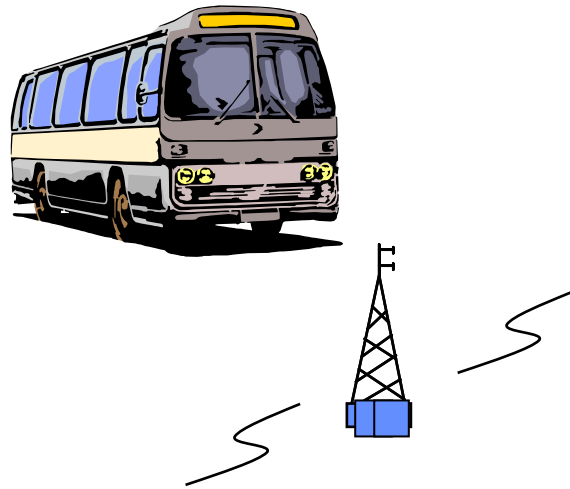

Base-station  
(infrastructure-centralized)

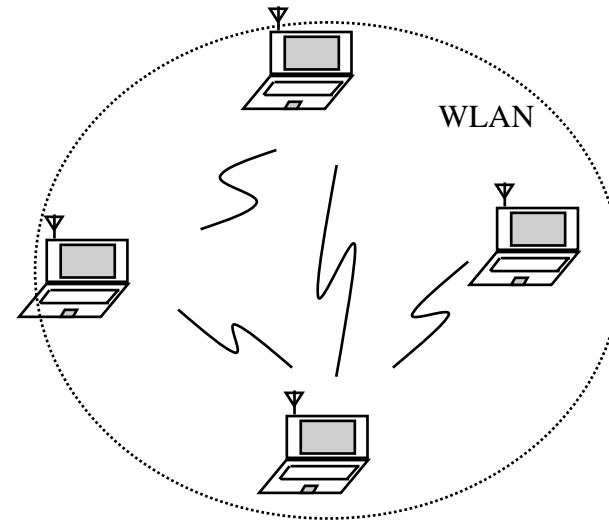

Peer-to-Peer  
(ad hoc network-  
Fully-connected vs multihop)

# Approaches to Wireless Multiple Access

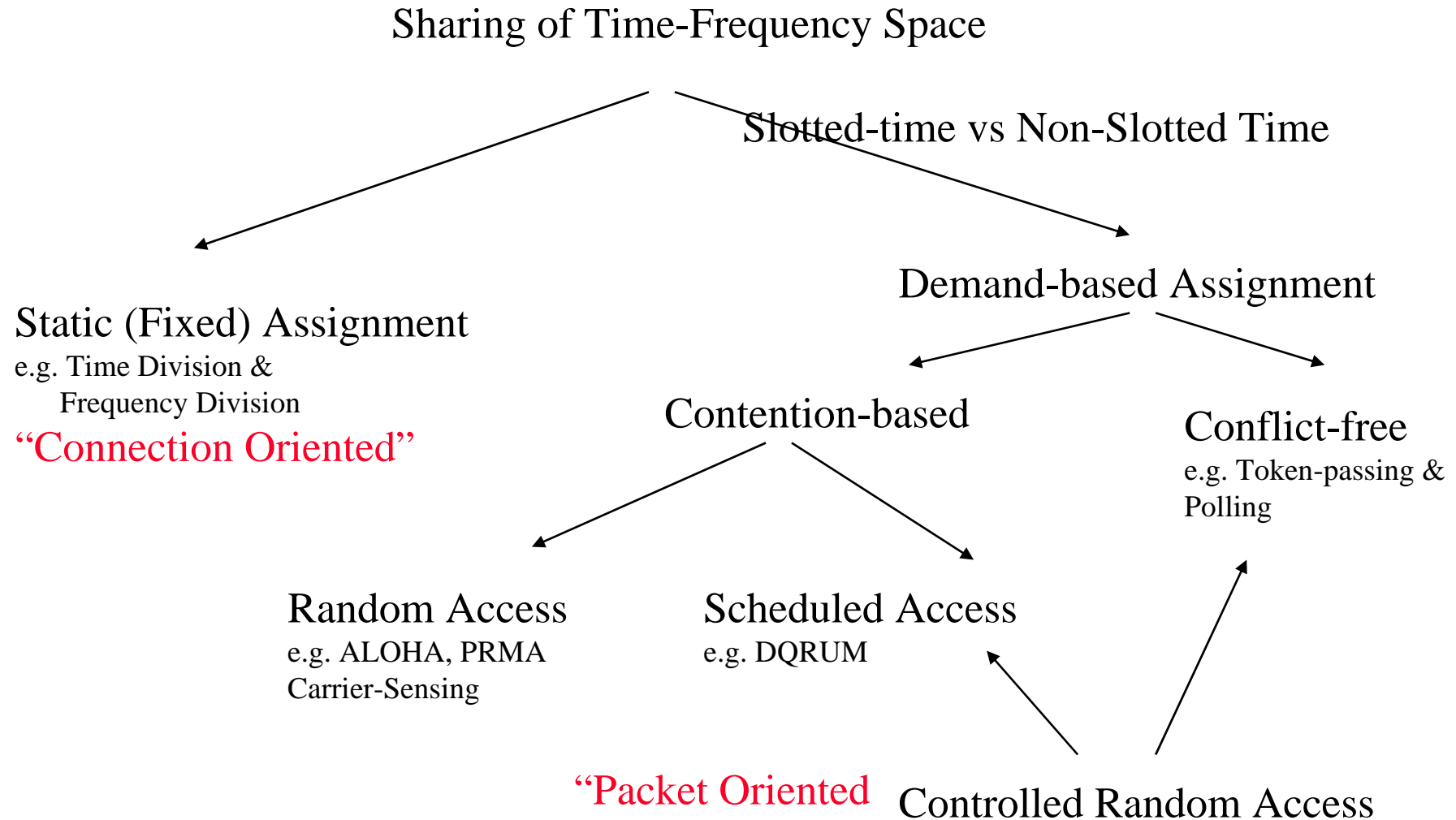

# Frequency Division & Time Division Duplexing



## ◆ Frequency Division Duplexing (FDD)

- Two distinct frequency at the same time for the two directions
- Frequency separation must be coordinated to allow cheap RF technology
- Coordination with out-of-band users between the two bands
- Geared towards providing individual frequencies for each user

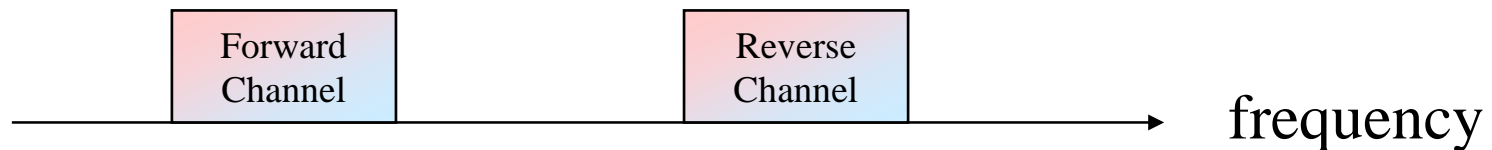

## ◆ Time Division Duplexing (TDD)

- Two distinct sets of time slots on the same frequency for the two directions
- Time latency because only quasi-duplex
- No need for RF duplexer

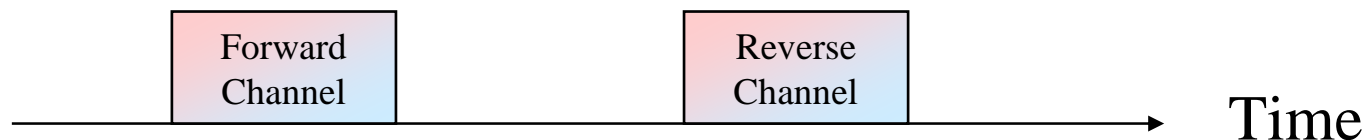

# Frequency Division Multiple Access (FDMA)

- ◆ **Assign different frequency bands to individual users or circuits**
  - Frequency band (“channel”) assigned on demand to users who request service
  - No sharing of the frequency bands: idle if not used
  - Usually available spectrum divided into number of “narrowband” channels
    - ◆ Symbol time  $\gg$  average delay spread, little or no equalization required
  - Continuous transmission implies no framing or synchronization bits needed
  - Tight RF filtering to minimize adjacent band interference
  - Costly bandpass filters at basestation to eliminate spurious radiation
  - Usually combined with FDD for duplexing

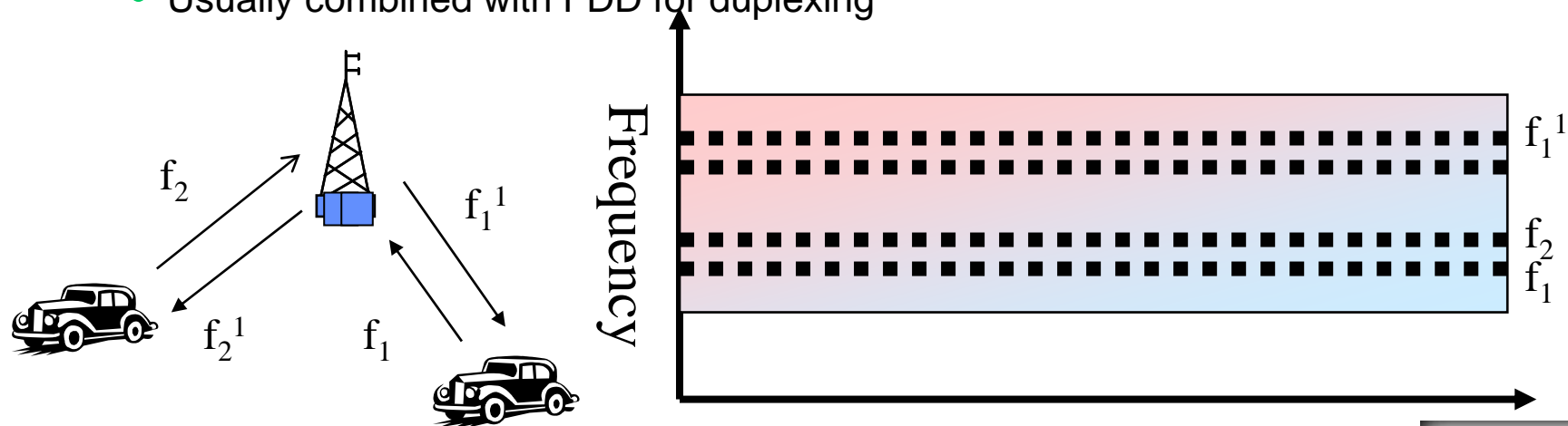

# Example-AMPS Cellular System

## ◆ User FDMA/FDD

- A channel is a pair of frequency duplexed simplex channels
- Each simple channel is 30 KHz
- Simple channels are separated by 45 MHz (allow cheap RF duplexers)
- Forward link 869-894 MHz, reverse link 824-849 MHz
- Two carriers per market share the channels

## ◆ Number of supported channels in AMPS

$$N = \frac{B_{total} - 2B_{guard}}{B_{channel}} = \frac{12.5MHz - 2(10kHz)}{30KHz} = 416$$

## ◆ Problem: set of active users is not fixed

- How is the FDMA/FDD allocated to a user who becomes active?
  - ◆ Static multiple access is not a complete solution .. Need a separate signalling channel with “demand-access”.
  - ◆ Pure FDMA is basically “dead” in the digital world

# Time Division Multiple Access (TDMA)

- ◆ **Multiple user share frequency band via cyclically repeating “time slots”**
  - “channel”==particular time slot reoccurring every frame of N slots
  - Transmission for any user is non-continuous: buffer-and-burst digital data & modulation needed, lower battery consumption
  - Adaptive equalization is usually needed due to high symbol rate
  - Larger overhead-synchronization bits for each data burst, guard bits for variations in propagation delay and delay spread
  - Usually combined with either TDD or FDD for duplexing
    - ◆ TDMA/TDD: half the slots in a frame used for uplink, half downlink
    - ◆ TDMA/FDD: identical frames, with skew (why), on two frequencies

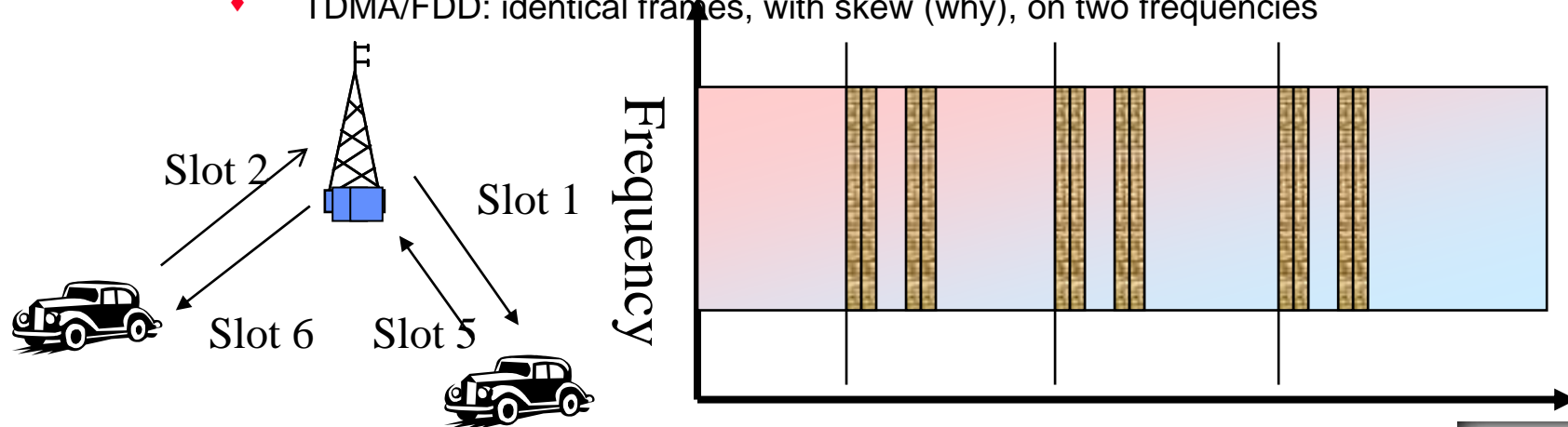

# TDMA

- ◆ **More features**
  - Simply mobility & link control.. Snoop for other BSs during idle slots
  - Pulsating power envelop:interference with devices such as hearing aids
  
- ◆ **Possible enhancements to basic TDMA to integrate non-voice services**
  - Different # of slots per frame to different users (variable bit rate)
  - Dynamically reassign time slots for “bandwidth on demand”

# Packet Radio

- ◆ **Packet Nature**
  - If we could deliver information by packet
  - Bursty Type of Traffic
  - Packet Size



# CSMA with Collision Detection/Avoidance

- ◆ **CSMA/CD: enhancement to slotted or unslotted CSMA schemes**
- ◆ **Node monitors its own transmission**
  - If collision detected, transmission is aborted without waiting for a NACK backoff and re-transmission procedure started
  - A jamming signal may be sent to get everybody else to abort too
- ◆ **Problem: does not work with RF wireless**
  - Cannot easily sense the channel while transmitting
    - ◆ MH's signal will dominate, need different receiving and transmitting antenna patterns
- ◆ **But, does work well with infrared wireless.. Directional receivers**
- ◆ **Wireless networks stick with ACK/NACK approach**
  - Popular called CSMA/CA
  - 802.11

# RANDOM Access

- ◆ Give everybody freedom



# Hawaii Story

- ◆ University of Hawaii
- ◆ ALOHA
  - Hello and Goodbye

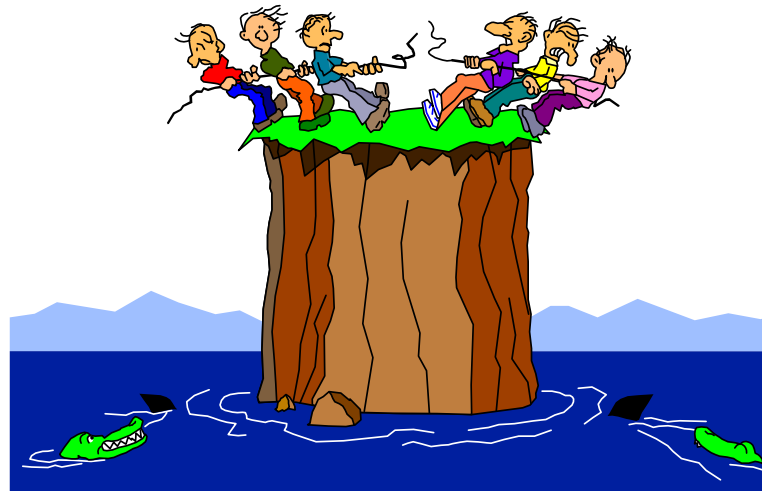

# ALOHA System

- ◆ If you want, transmit
- ◆ If no acks
  - wait a random time
  - transmit the same packet again
- ◆ Problem ?
  - Collision ?
  - A lot of Users ?



# Pure ALOHA Throughput

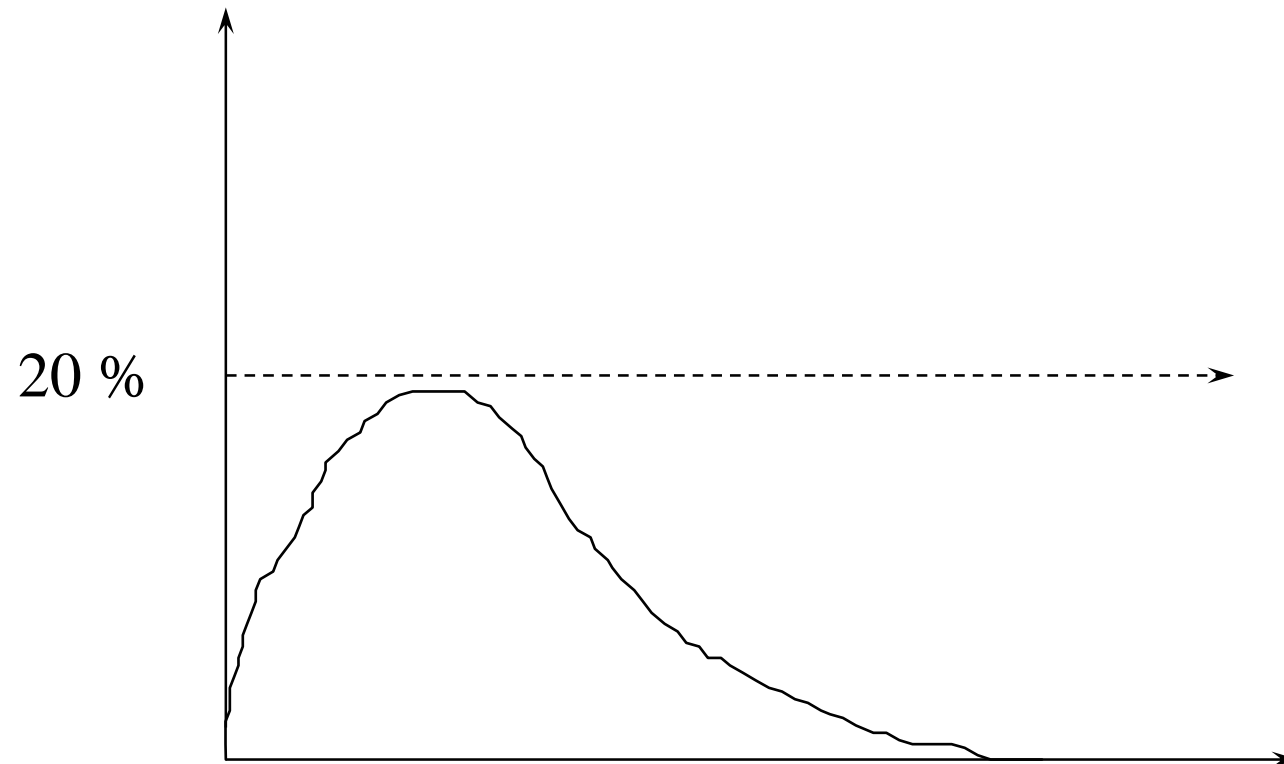

Traffic Load

# Slotted ALOHA Throughput

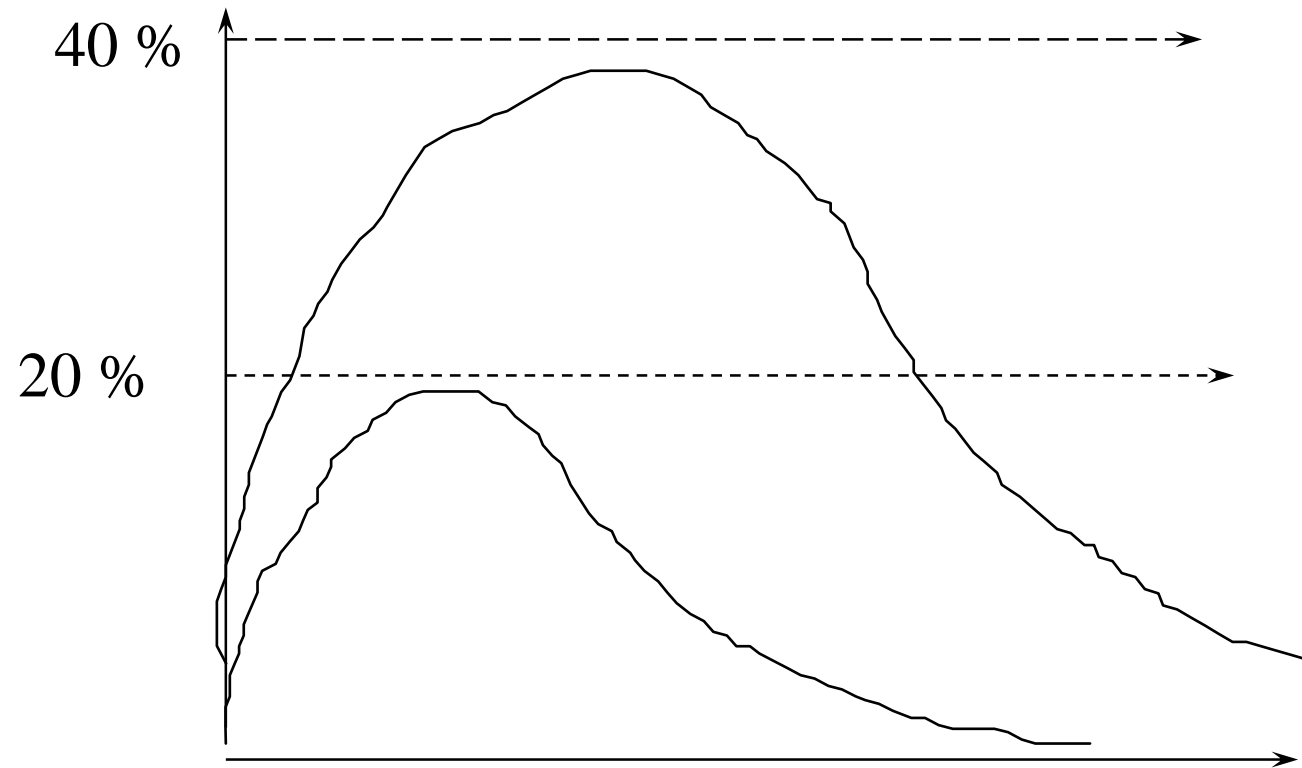

Traffic Load

# Slotted ALOHA

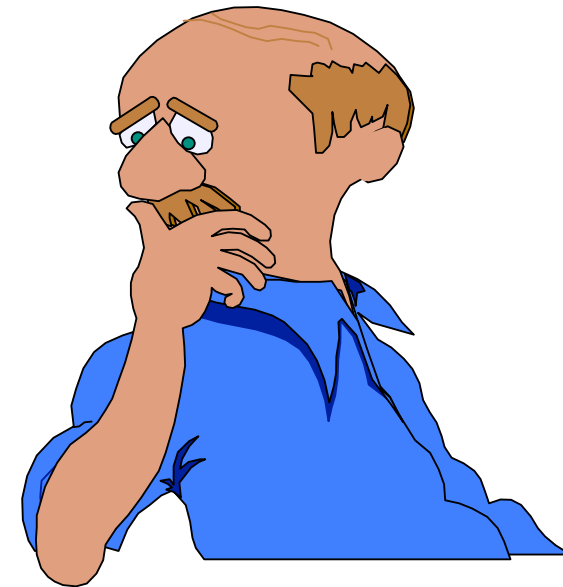
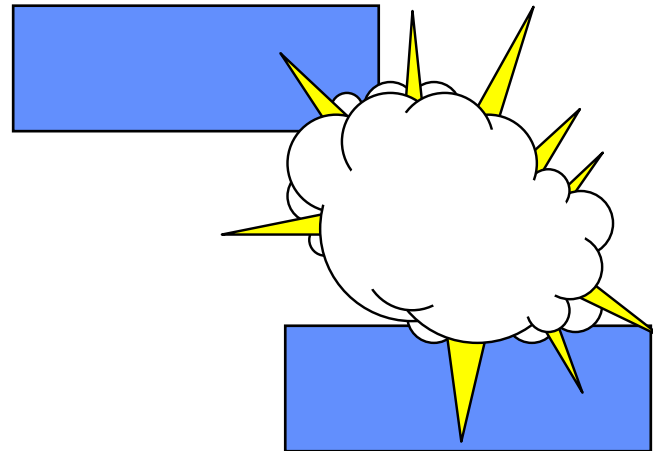

Maybe We could do  
some arrangement ?

# QoS & Delay

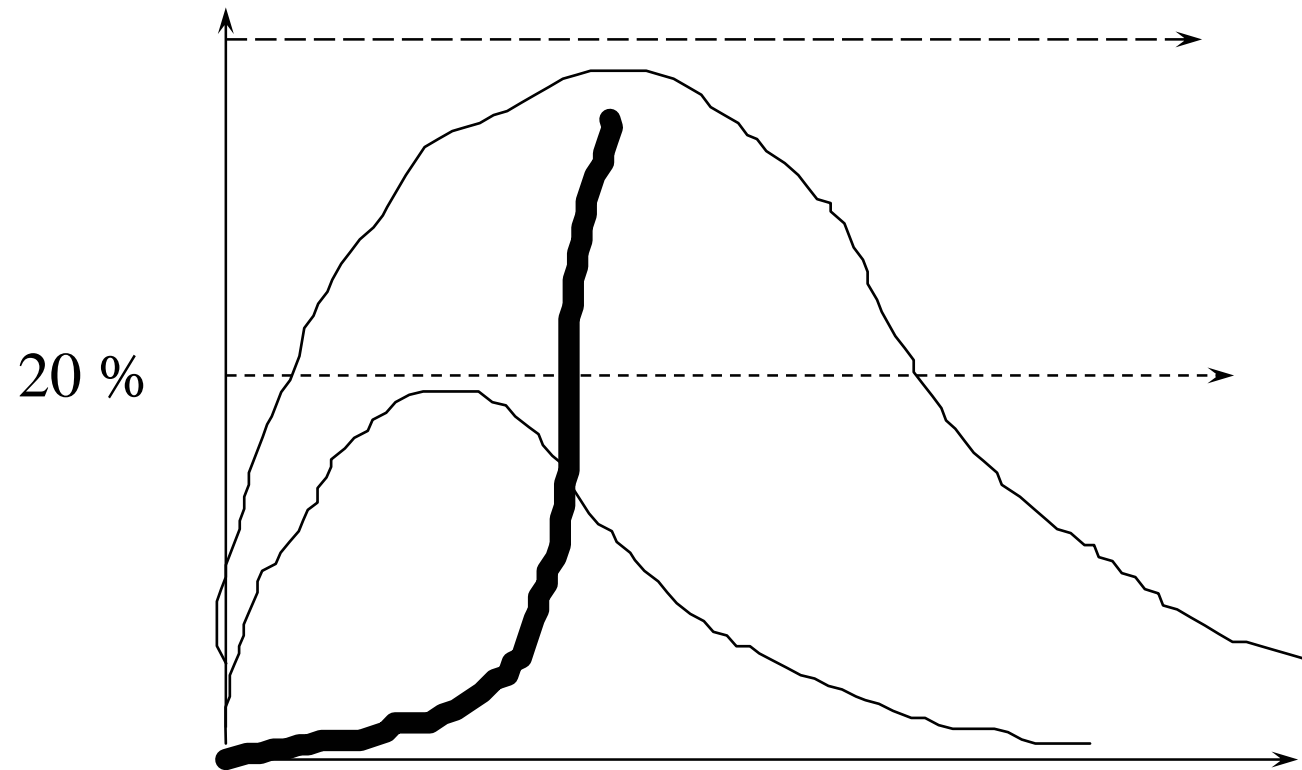

Traffic Load

**DELAY**



# Whenever Users are many

- ◆ No one will succeed
- ◆ Collides all the time



# Reason

- ◆ No one really listen to other people
- ◆ No one really cares

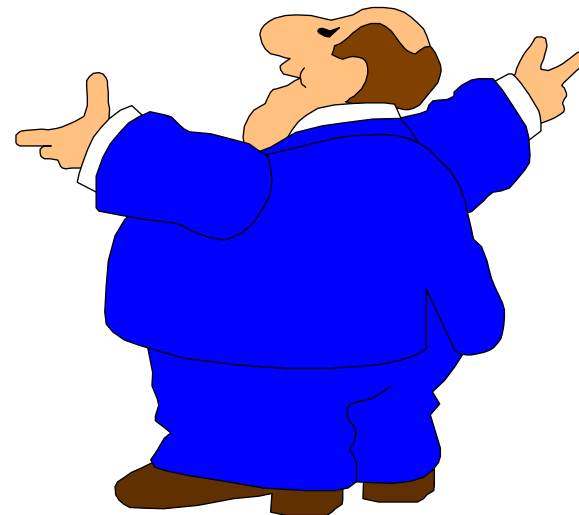

# CSMA

- ◆ **Most LANs use CSMA**
- ◆ **Carrier Sense**
  - CSMA/CA: Collision Avoidance
  - CSMA/CD: Collision Detection

# CSMA

- ◆ **Check if carrier is ok**
- ◆ **if the channel is free**
  - transmit
- ◆ **Otherwise, if the channel is busy**
  - wait a random time and try again
  - Back of a random time

# CSMA

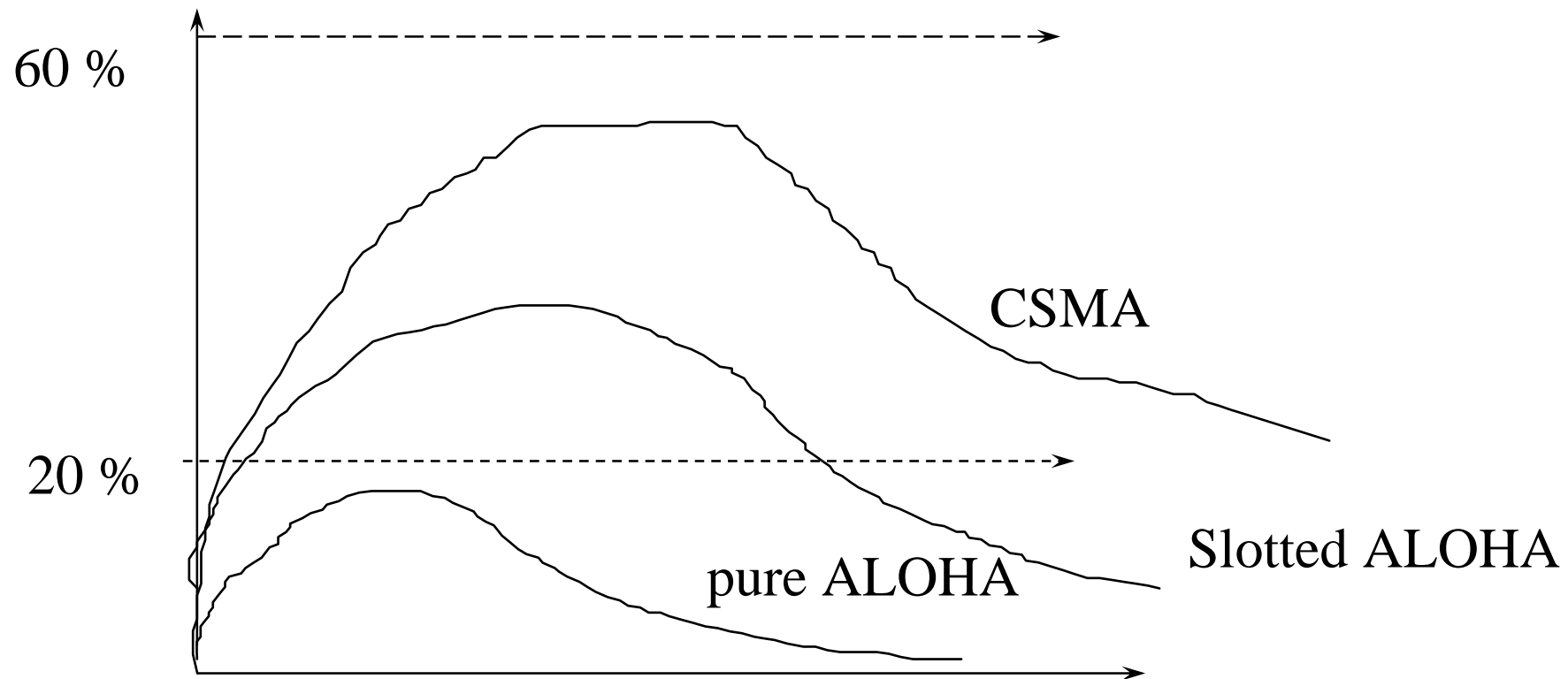

Traffic Load

# Integrated CSMA/TDMA MAC Protocol

- ◆ Hybrid of reservation and Random Access
- ◆ A frame is segmented into:
  - Two reservation intervals for isochronous traffic
  - One interval for random access traffic

# Can Support AP or Ad Hoc

- ◆ **AP (Access Point)**
- ◆ **Ad HOC**
  - Coordination Function will be distributed among all of the nodes of the ad hoc network

# Challenge of Wireless Network

- ◆ Does “listen before you talk “ work ?

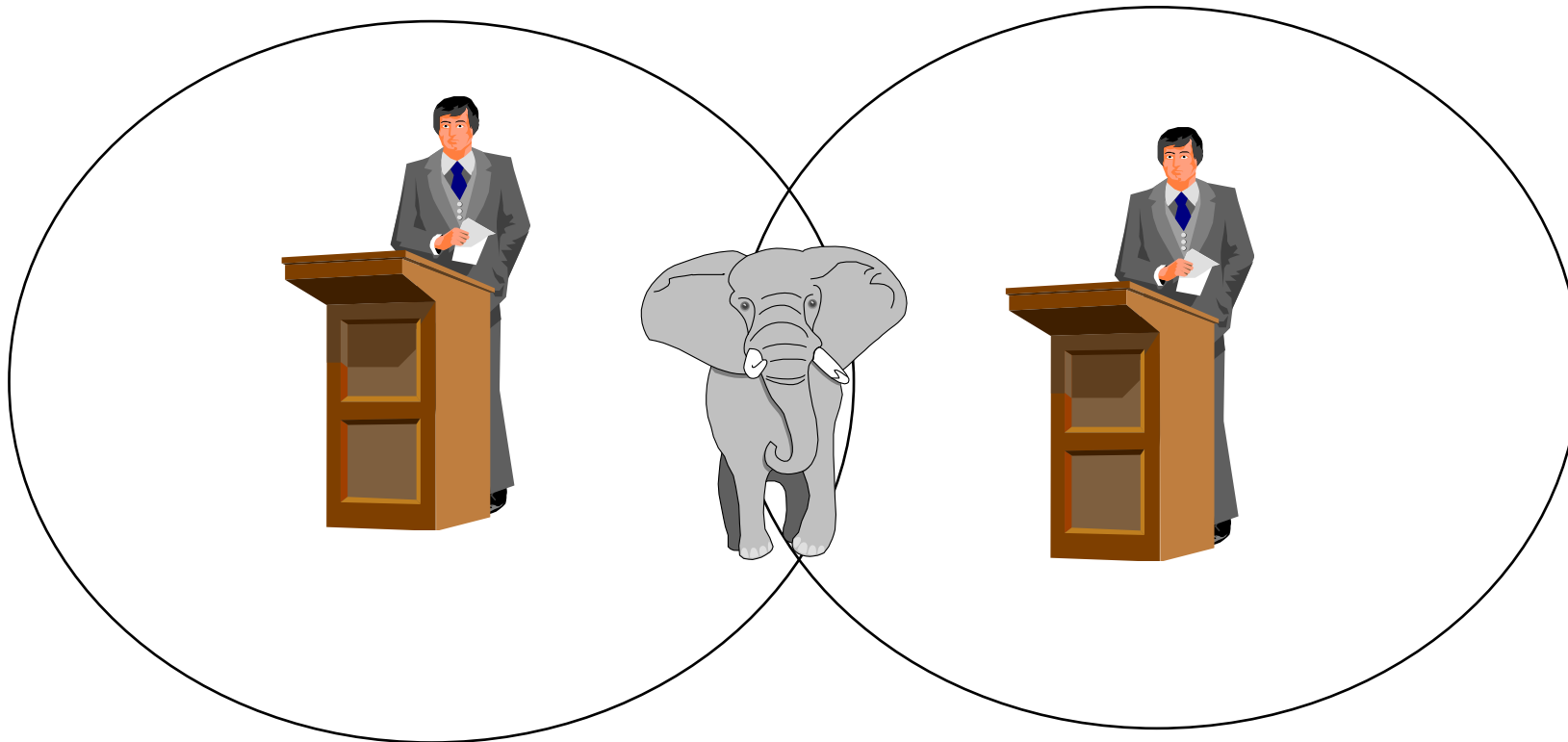



# Hidden Terminal

- ◆ Due to transimssion range

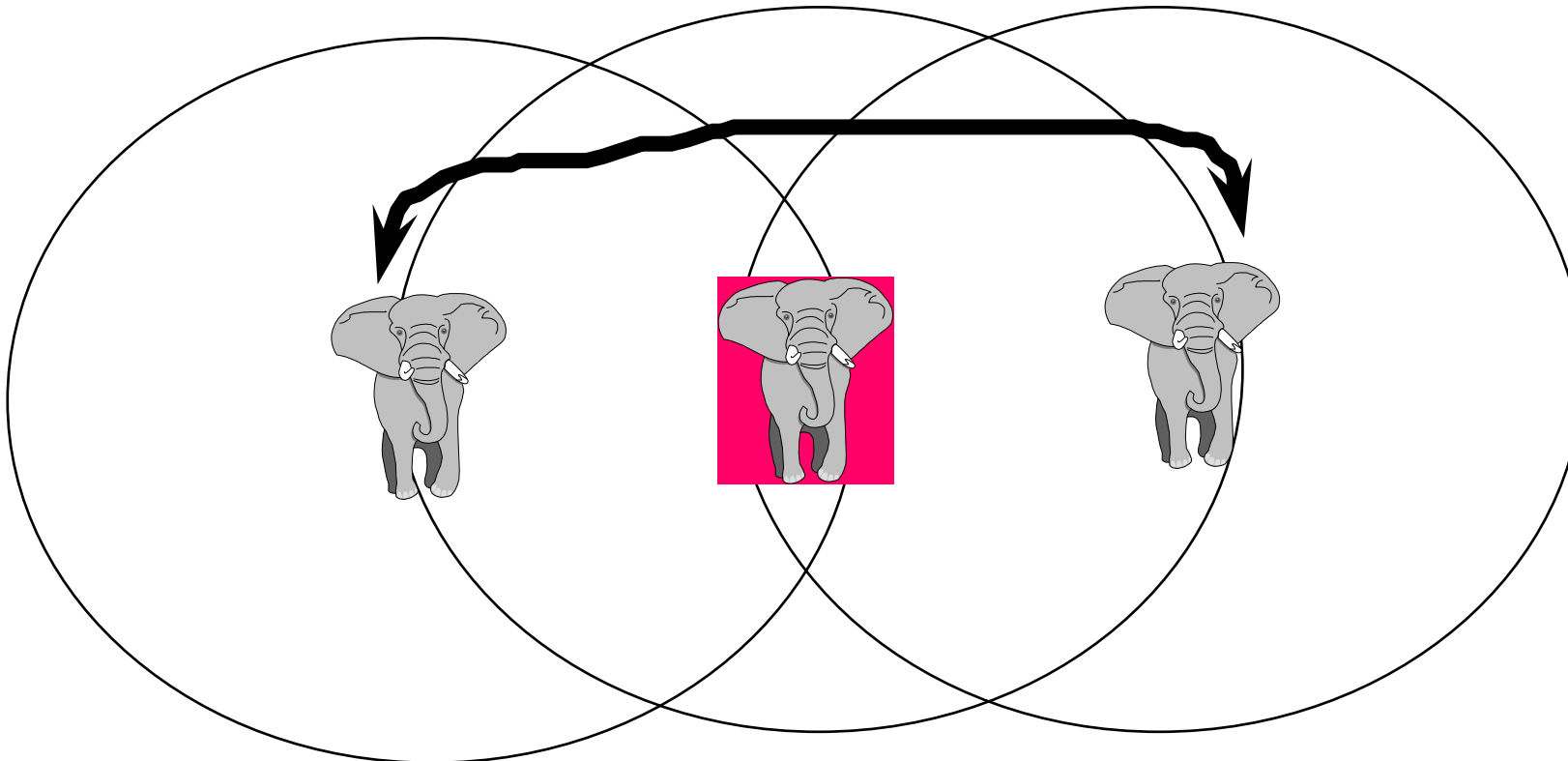

# RTS/CTS/ACK

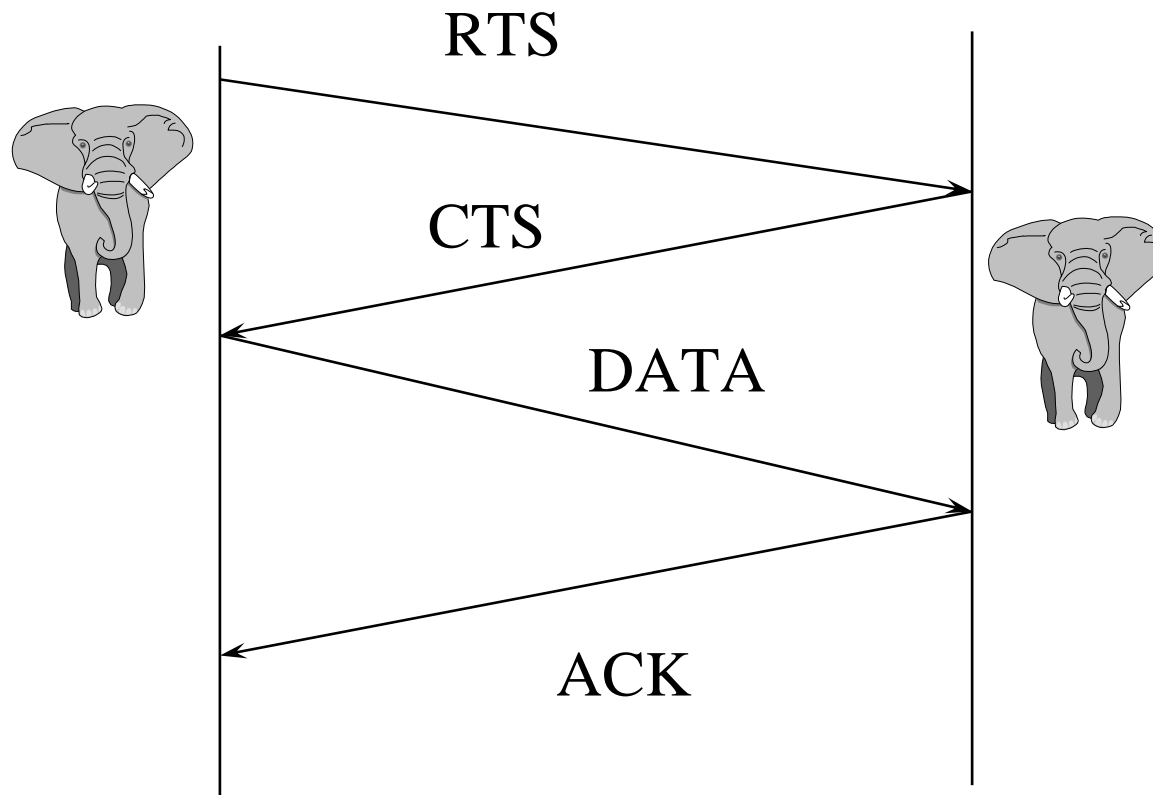

# Data Sense Multiple Access (DSMA)

- ◆ Variation of CSMA-also called inhibit Sense Multiple Access
- ◆ Basestation transmits a busy/idle message on a forward control channel
- ◆ Mobile listens on the forward control channel for the busy/idle message
- ◆ Mobile transmits on the reverse channel only if busy/idle message indicates that the reverse channel is free
- ◆ Back-off and retransmit if collision occurs nevertheless
- ◆ Used in CDPD (Cellular digital packet data)

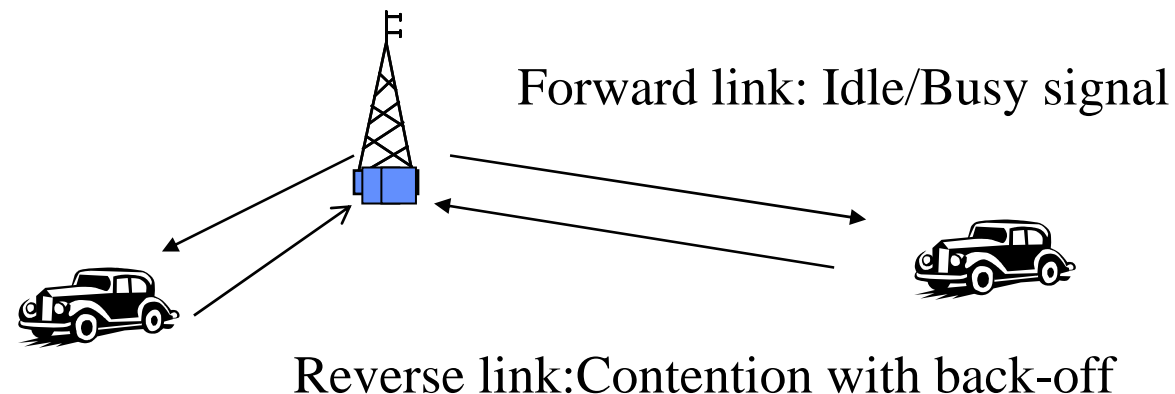

# Problems in Contention-based Wireless Multiple Access



- ◆ **Near-Far effect-characterized by capture ratio of the receiver**
  - Strongest (near by) transmitter can capture the intended receiver
  - Weaker (far away) transmitters get ignored by the receiver
  - Depends on receiver and modulation used
  - Fairness terminal problem
- ◆ **Hidden terminal problem**
  - Terminal “hidden” from the transmitter may disrupt the receiver
  - Makes carrier sensing ineffective
  - A cannot detect collisions at B due to transmission from C
  - Solve by using RTS/CTS control frame to reserve medium

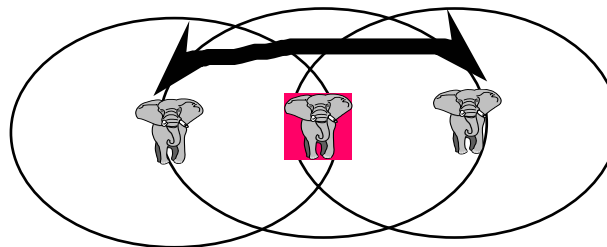

## More on RTS/CTS

- ◆ **RTS/CTS serve to “reserve” the medium**
  - RTS contains length of proposed transmission
  - CTS also contains length of proposed transmission
  - MHs overhearing RTS defer all transmissions until after CTS would have finished (including receiver turnaround time)
  - MHs overhearing CTS defer for length of data packet transmission
  - Retransmission happen only if no CTS is received in response to RTS
  
- ◆ **Binary exponential backoff (BEB) has problems**
  - Does not provide fairness if every MH generate enough traffic to consume the channel
  - After collisions, the less-backed-off mobile wins eventually all but one MD are backed-off to BOmax

# Exposed Terminal Problem

- ◆ **C will sense channel busy, and defer, but doesn't need to**
  - The C to D transmission can take place but is delayed

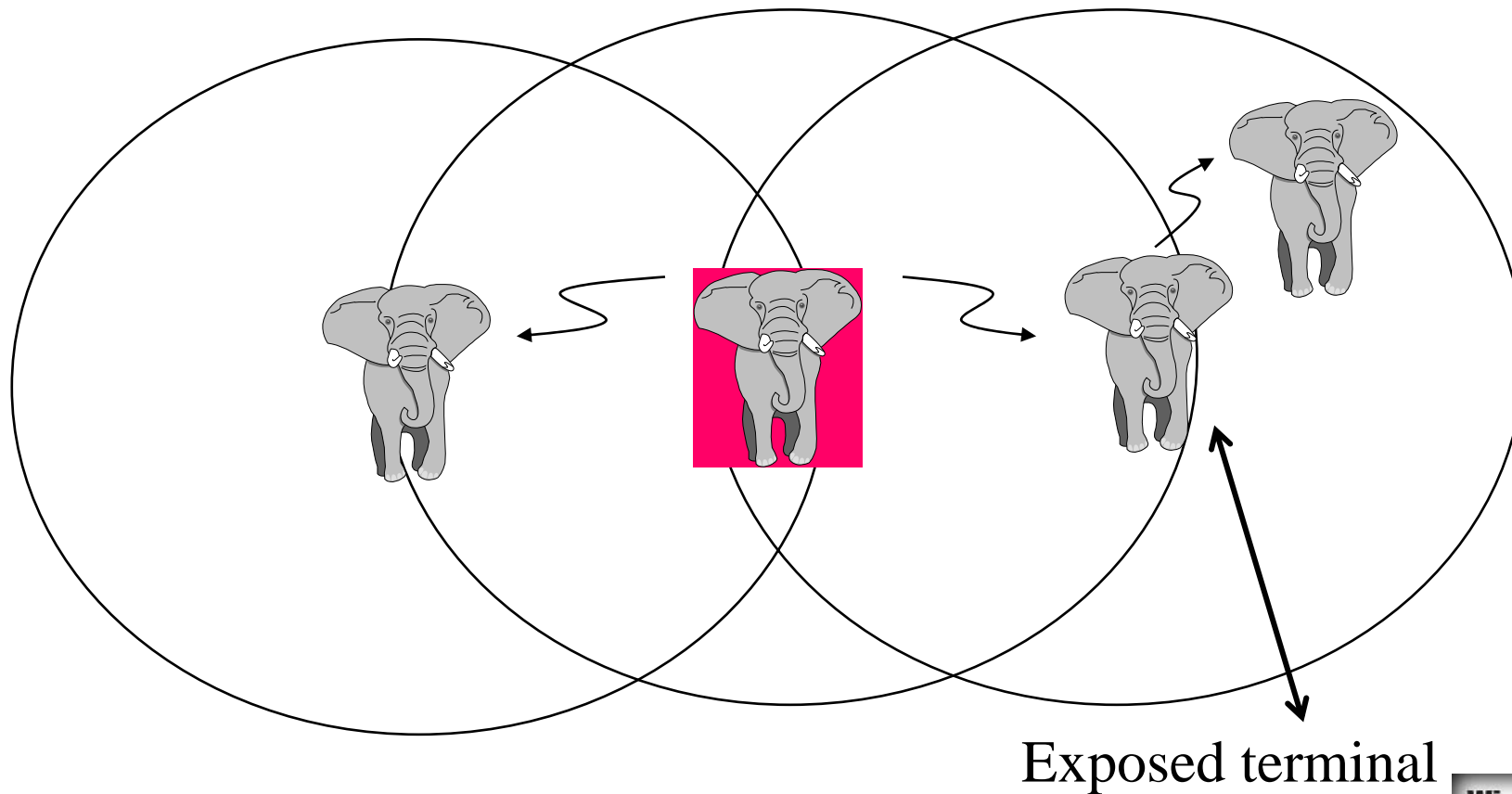

# CSMA/CD?

- ◆ Collision Detection ?
- ◆ If a collision is detected, stop transmitting the present packet ?
- ◆ Is CSMA/CD possible ?
  - transmit and receive at the same time ?
  - CSMA wireless network, transmit and receive at the same frequency band
  - unlike Cellular System, uplink and downlink

# IEEE 802.11 MAC

- ◆ **Support for multiple access PHYs; ISM band DSSS and FHSS, IR @ 1 and 2 Mbps**
- ◆ **Efficient medium sharing without overlap restrictions**
  - Multiple networks in the same area and channel space
  - Distributed Coordination Function: using CSMA/CA
  - Based on carrier sense mechanism
- ◆ **Robust against interference (e.g. co-channel interference)**
  - CSMA/CA+ACK for unicast frame with MAC level retransmission
- ◆ **Protection against Hidden terminal problem: Virtual Carrier Sense**
  - Via parameterized use of RTS/CTS with duration information
- ◆ **Provision for Time Bounded Services via Point Coordination Points**
- ◆ **Configurations: ad hoc & distributed system connecting access points**
- ◆ **Mobile-controlled hand-offs with registration at new basestation**



# Schedule Access-Reservation-based Protocols



- ◆ Also called “Demand Assigned Multiple Access”
- ◆ Center agent that acts a slot scheduler
- ◆ Sender request “reservations” for future time slots
- ◆ Central agent assigns a slot
- ◆ Data transmission in the assigned slot is done without contention
- ◆ Assumption is that data packets  $\gg$  reservation request packets
- ◆ Overhead of reservation and acknowledgement messages
- ◆ Trades higher throughput (up to 80% utilization) for higher latency

# Order MAC Techniques

- ◆ **Token Bus and Token Ring**
  - Token are passed among nodes
  - How about wireless network ?
    - ◆ Nodes might leave ?
    - ◆ Break the Order
    - ◆ Take away the token

# From Distributed to Centralized Control

- ◆ from Random to Deterministic MACs

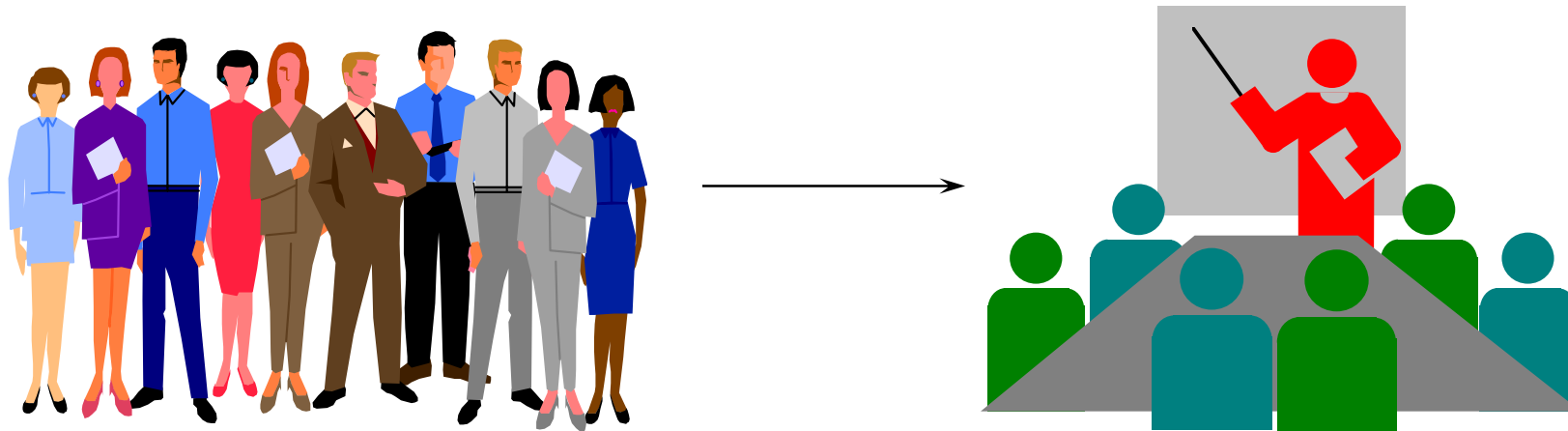

# Integrated CSMA/TDMA MAC Protocol

- ◆ Hybrid of reservation and Random Access
- ◆ A frame is segmented into:
  - Two reservation intervals for isochronous traffic
  - One interval for random access traffic

# Integrated MAC frame structure

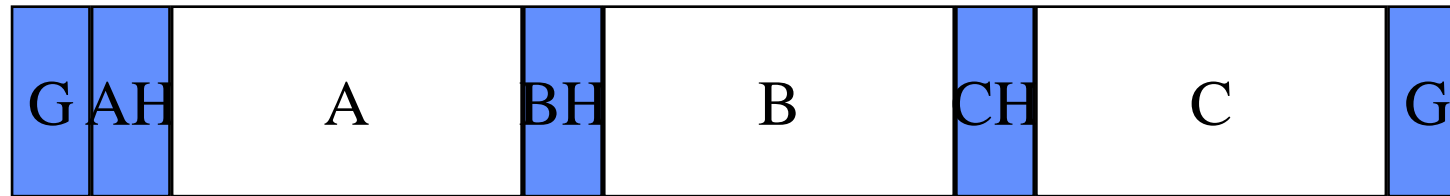

Reservation based

Reservation based

Contention based

from AP to MS

from MS to AP/MS

from MS to AP/MS

# Whenever you want ?

- ◆ Ask the permission from the Control Point

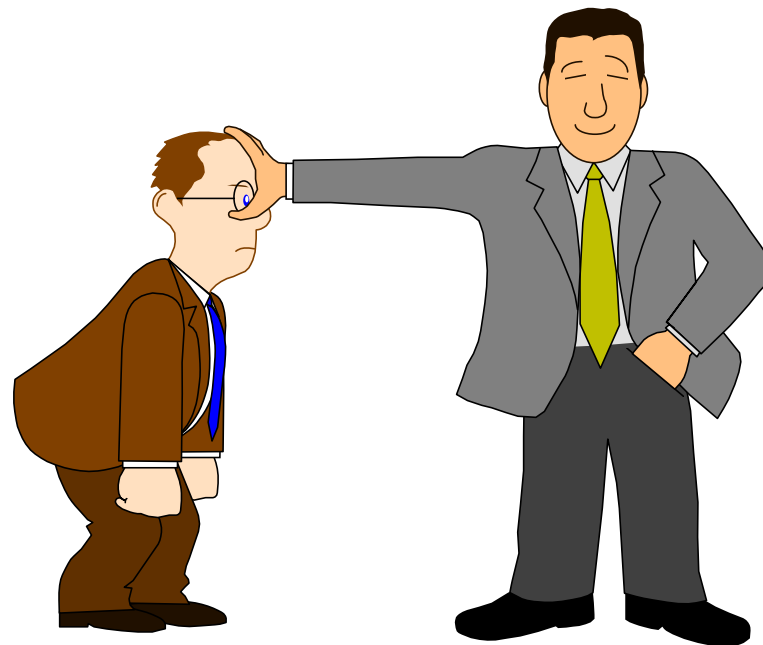

# Deterministic MACs

## ◆ Ask Permission

- slow down the lightning fast access
- improve the throughput and response time when traffic is heavy
- guaranteed bandwidth requirements
- FDMA, CDMA, TDMA

# Flexibility

- ◆ Traffic is light, it is left to be mostly random
- ◆ Traffic is heavy, the control point allocates bandwidth deterministically

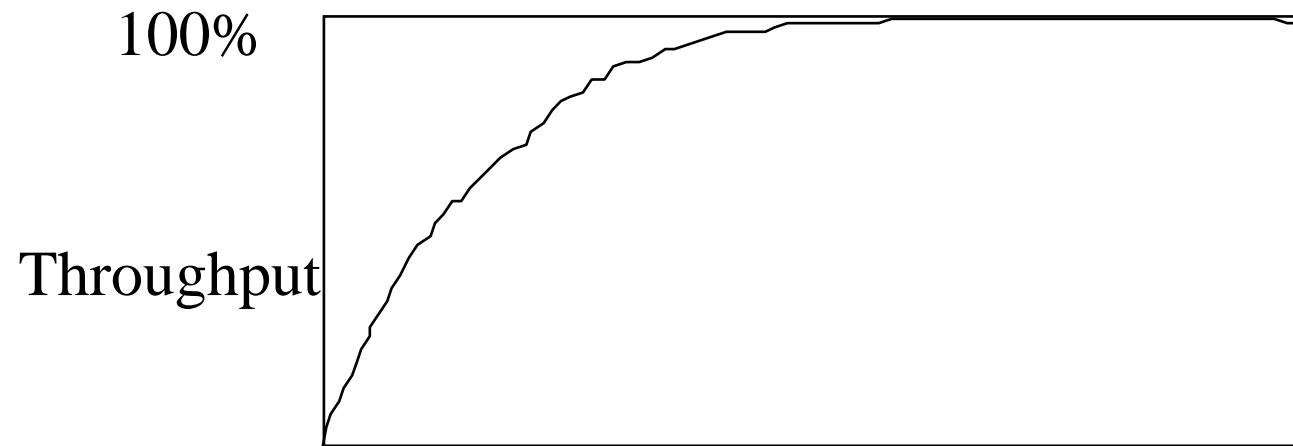



# Comparison of MACs

- ◆ **Random Access: CSMA**
  - Under light load: Fast Response Time
  - Under heavy load: Throughput declines
  - Simple to implement

# Comparison of MACs

- ◆ **Deterministic protocols: FDMA, TDMA, CDMA**
  - Able to provide guaranteed bandwidth
  - Larger average delay
  - Smaller delay variance

# Comparison of MACs

## ◆ Mixture: CSMA/TDMA

- Under Light Load: Fast Response Time
- Under heavy load: Throughput approaches TDMA
- Higher overhead

# Reservation/Polling MAC

- ◆ How to provide fairness and short message together ?
- ◆ Reservation and Polling

# Fairness Problem

- ◆ Could you guarantee someone to transmit ?



# Stock Trading

- ◆ Everybody would like to do the stock trading as soon as possible
- ◆ The fairness of the MAC is utmost importance

# IBM Polling Solution

## ◆ TDMA system

- slow average access time but fair
- a node has a packet to send, it sends a request to the control point
- the control point will poll the users in turn
- the data transmission is acknowledged
- no ad hoc networking is possible

# Multiple Access Techniques for Different Traffic Types



Type of Traffic	Multiple Access Technique
Short, bursty messages	Random access protocol
Long, bursty messages Large number of users	Schedule access (Reservation) protocol
Long, Bursty message Small number of users	Reservation protocols with fixed TDMA reservation channel
Deterministic traffic	FDMA, TDMA, CDMA



# Our Adventures !



**Homework you are going to do!**



# Wireless Communications

- ◆ Mobile Communications



# How does wireless transmission succeed ?

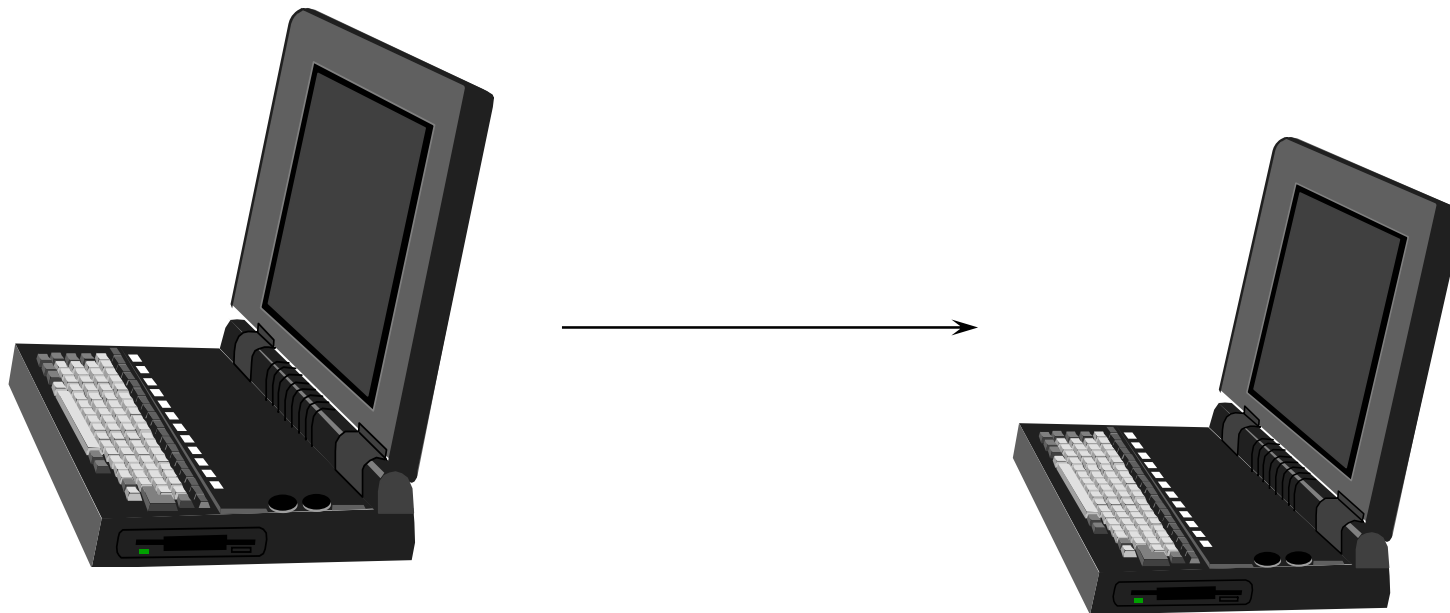

# Single Hop Experiments



Distance  
Packet Size  
Data Rate  
Mobility



# CSMA/CA & RTS/CTS Comparison Experiments

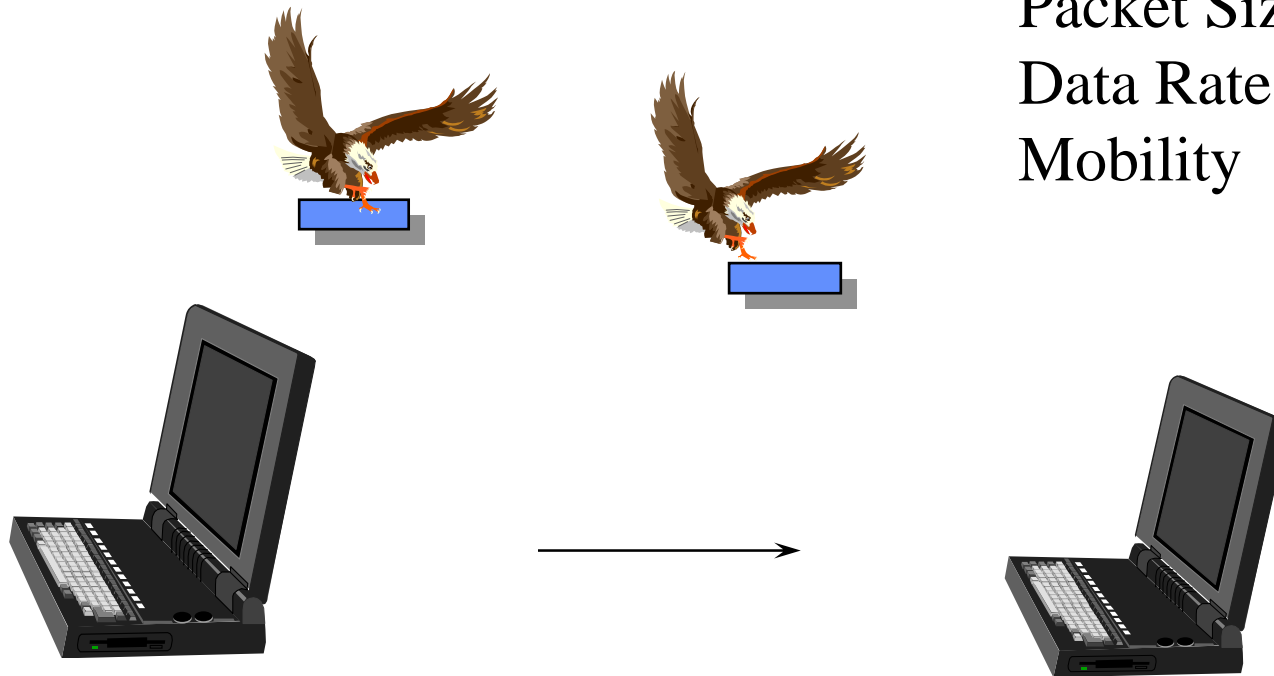

Distance  
Packet Size  
Data Rate  
Mobility

# Hidden Terminal Experiments

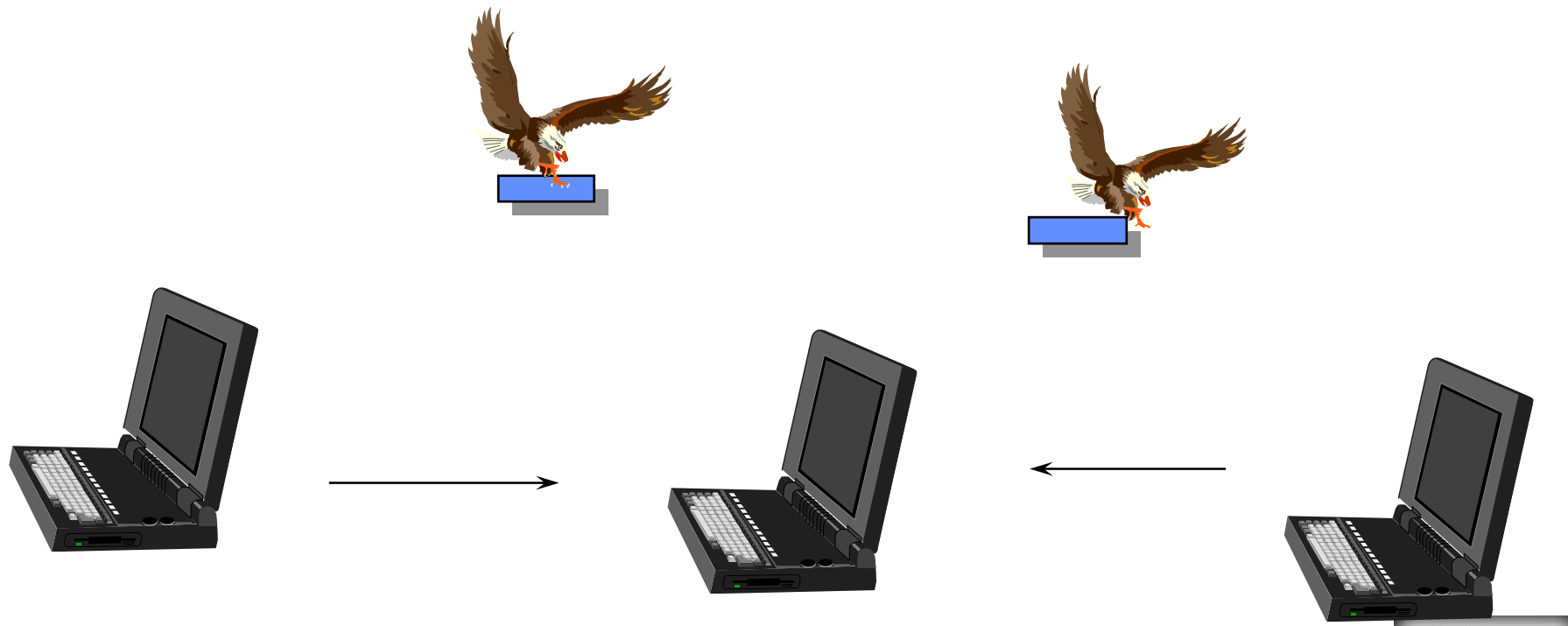

# ACK Study

- ◆ End to End Acknowledgment
- ◆ Hop by Hop Acknowledgement



# Current Status

- ◆ **Most Wireless LAN**
  - use CSMA/CA random access
- ◆ **Mobile Data:**
  - Random Access
  - Slotted ALOHA
- ◆ **Data over GSM**
  - Circuit Switch



# Whenever a Computer Comes to new AP

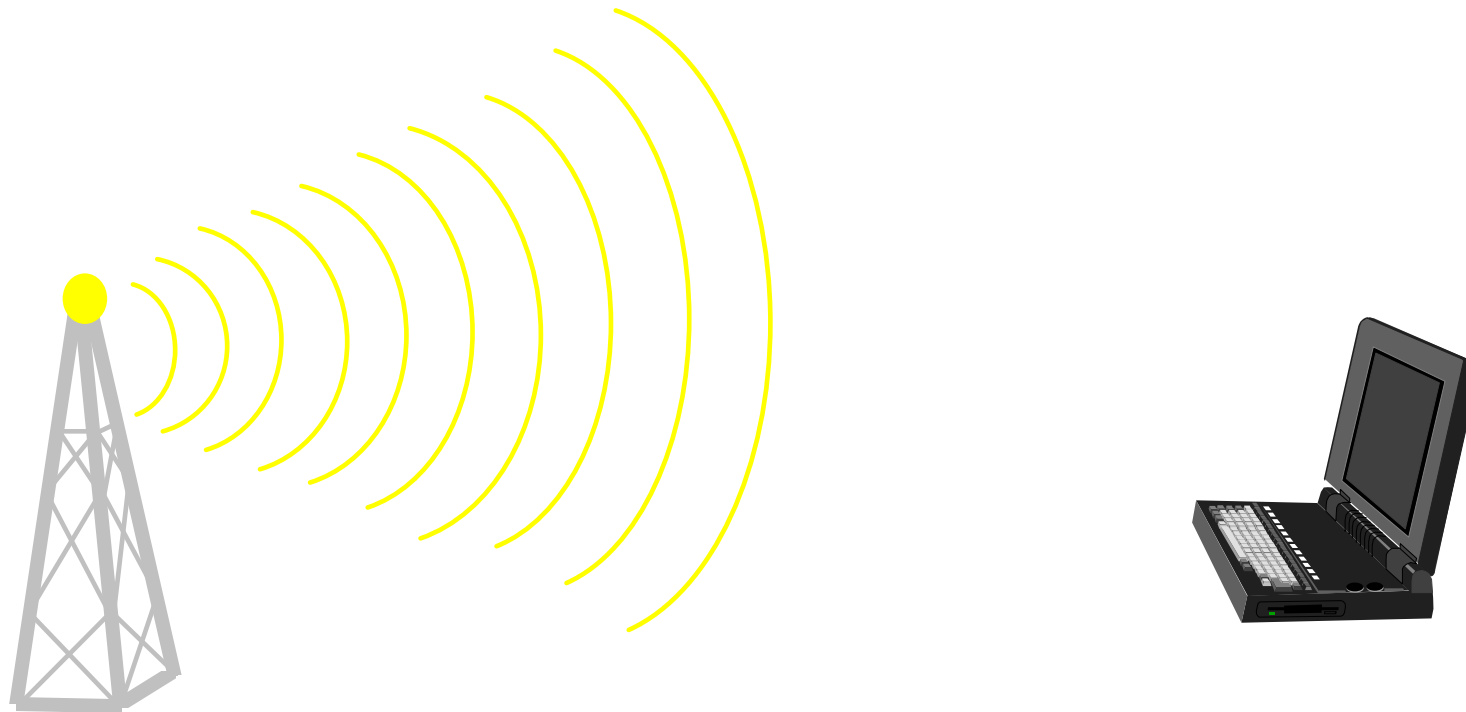



## **Association**

Establishing an association between a station and an AP

## **Re-Association**

Handover to another AP

## **Authentication**

When a station convince an AP its identity

## **Privacy**

Encryption of the data

## Basic Scenario

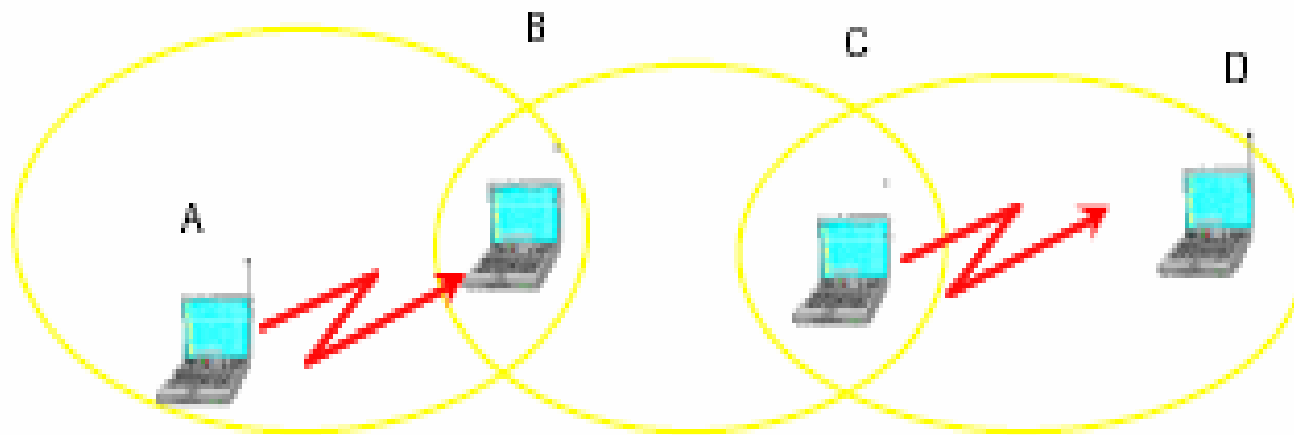

Fig. 1. A is sending a packet to B when C should decide whether to transmit to D.

# Hidden and Exposed Stations

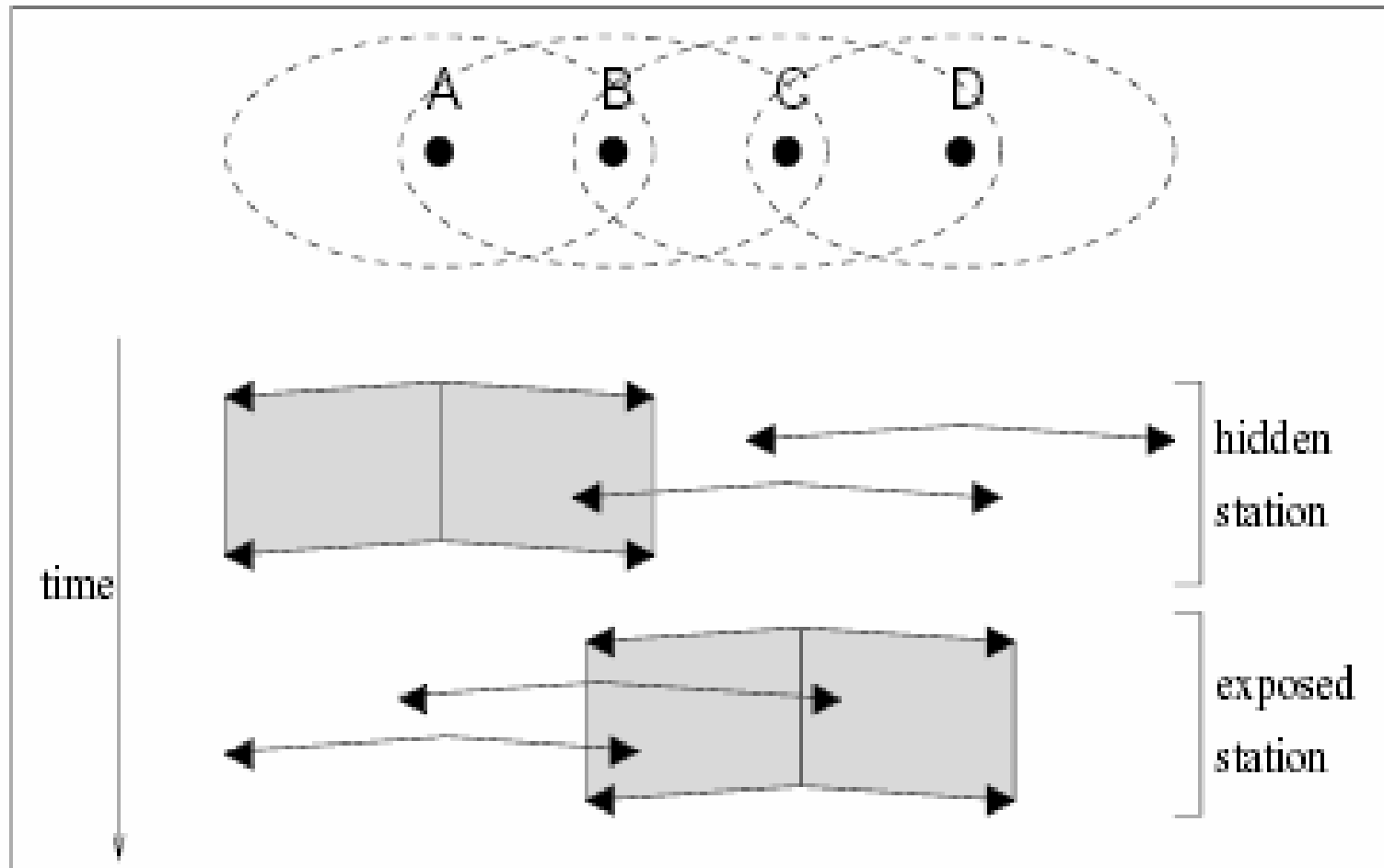

Figure 1: Hidden and Exposed Stations

# Capture Effect/Near Far Problem

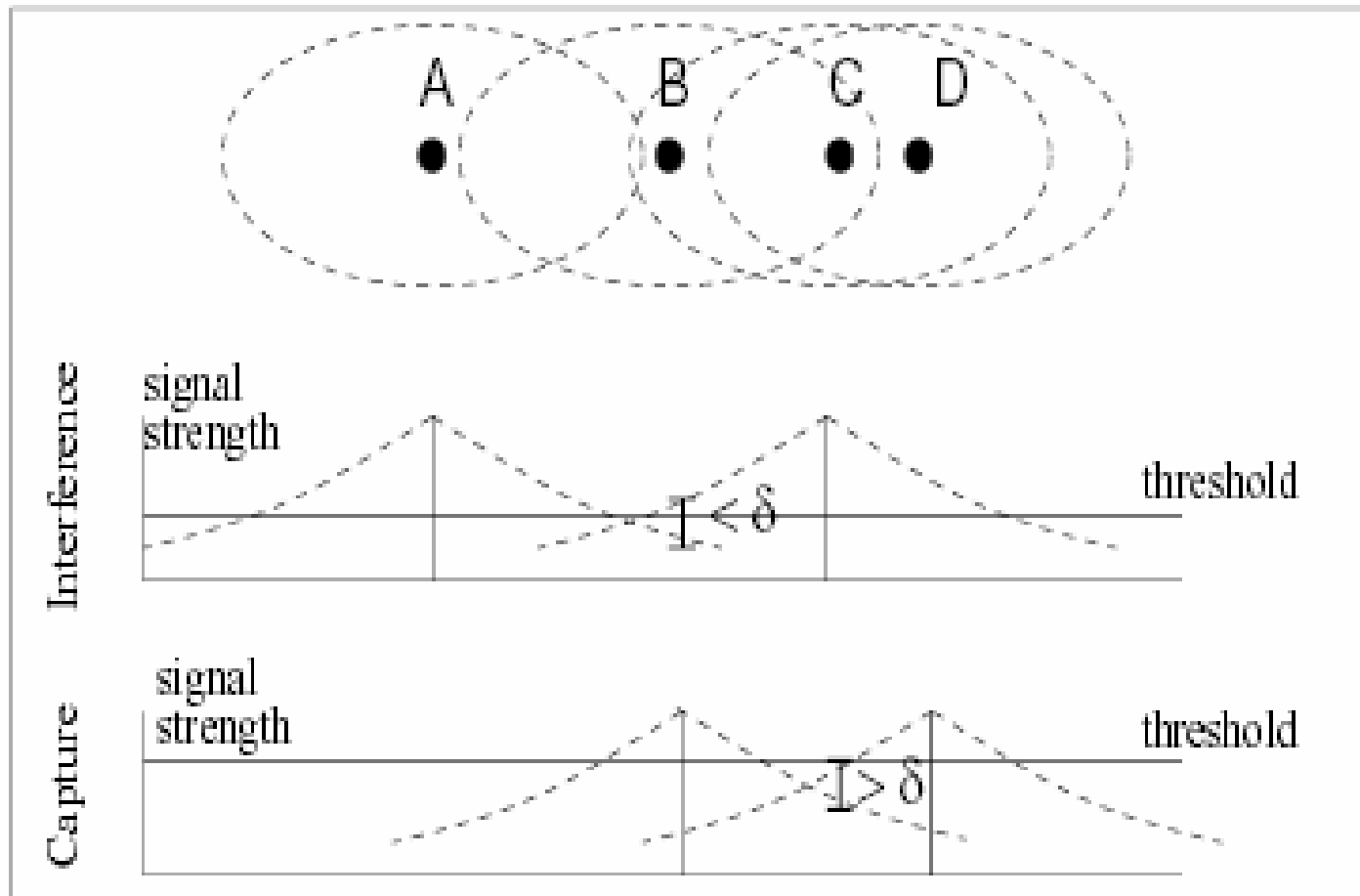
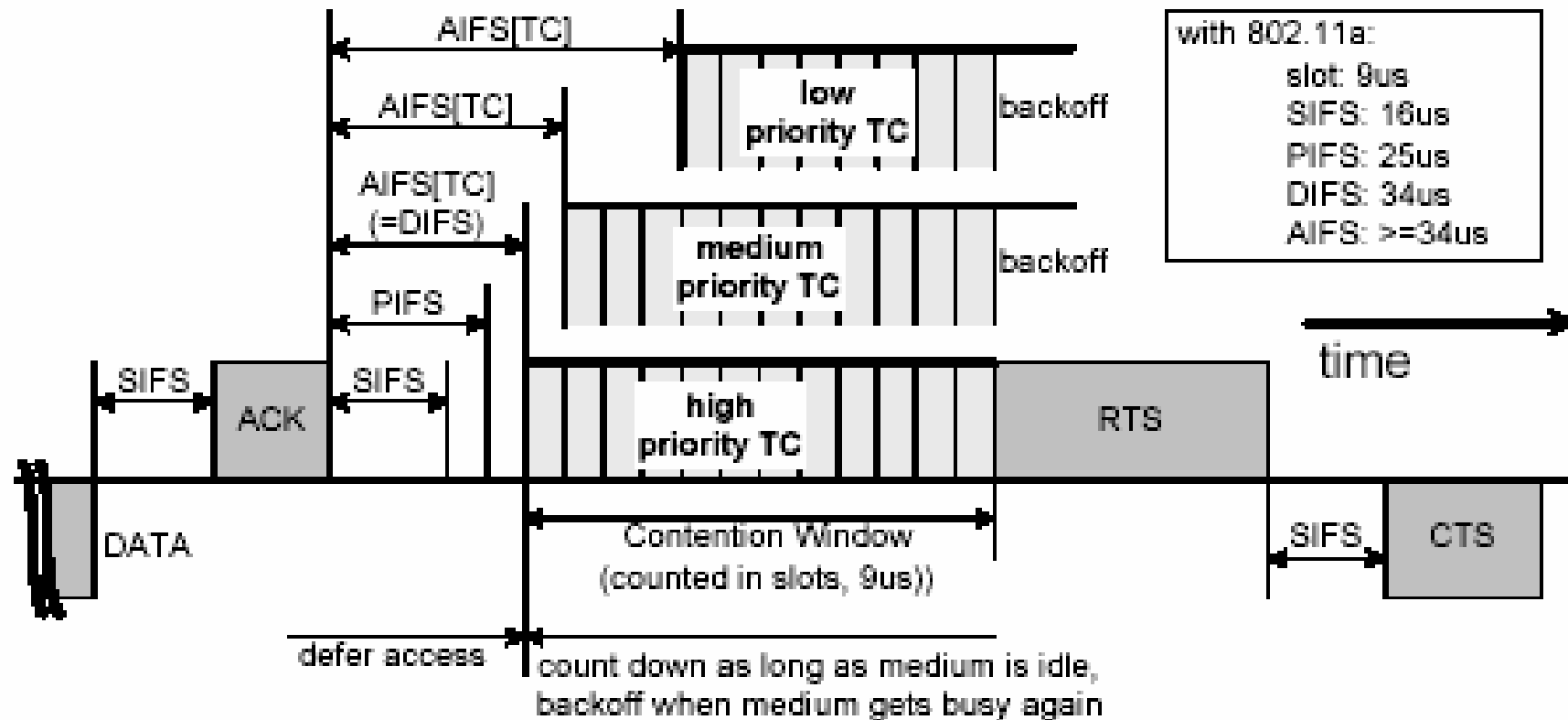
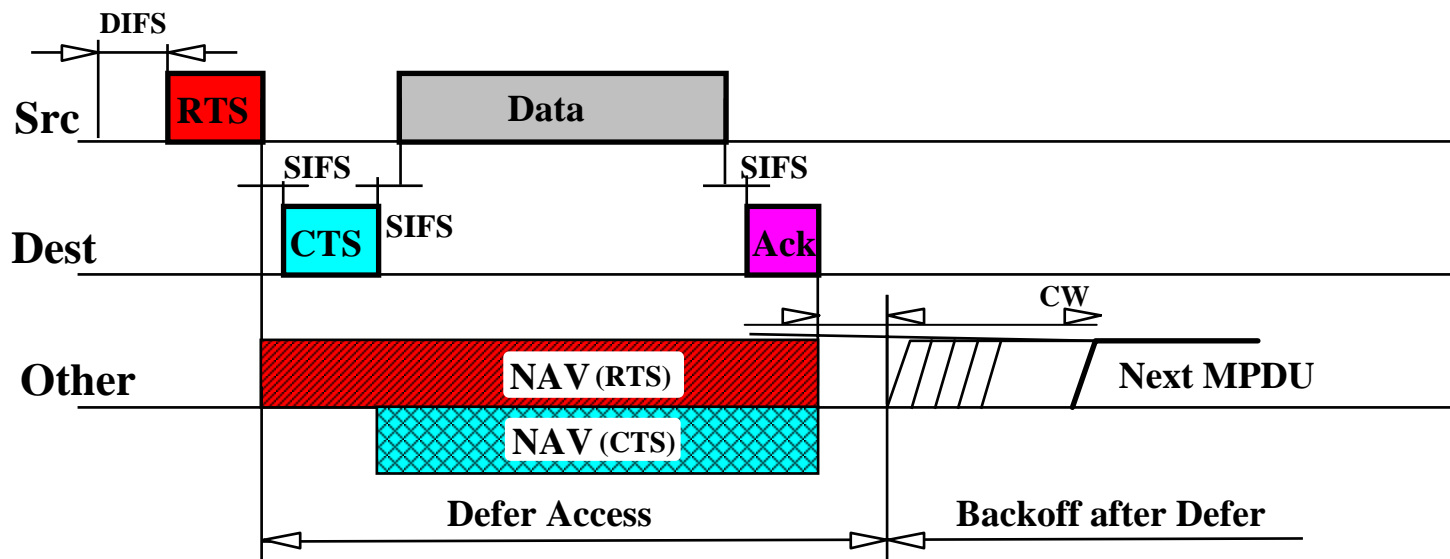

Figure 2: Interference and Capture

# 802.11 E



# 802.11



# Interference Issue for CSMA/CA

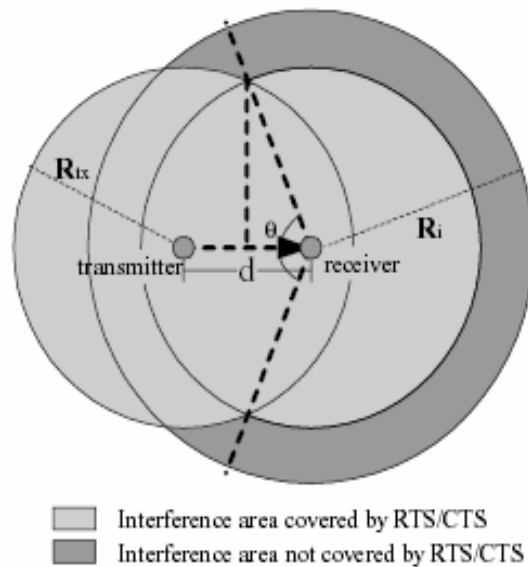

Fig. 1. Effectiveness of RTS/CTS handshake when  $d$  is larger than  $T_{SNR}^{-\frac{1}{\alpha}} * R_{tx}$  and smaller than  $R_{tx}$ .

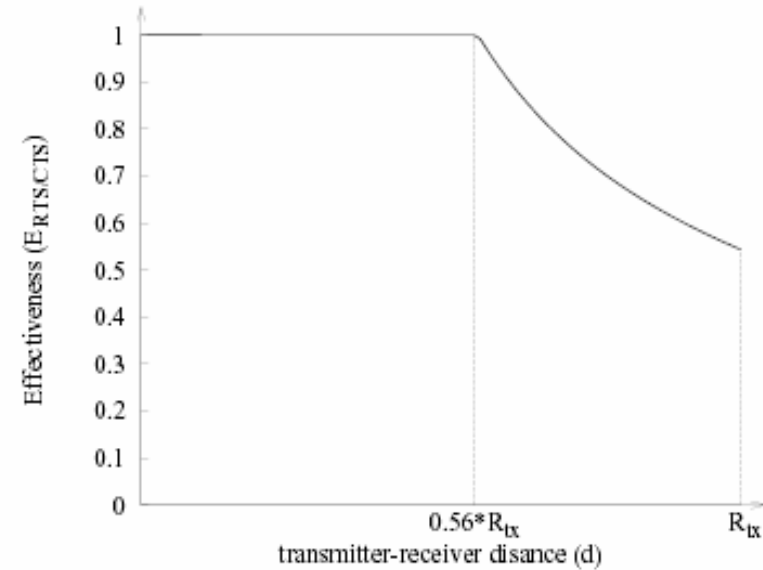

Fig. 2. Effectiveness of RTS/CTS handshake for TWO-RAY GROUND model and SNR threshold as 10.



# QoS issue for 802.11

